

CANopen Slave Driver

1	System Configuration.....	3
2	External Device Selection	5
3	Communication Settings	6
4	Setup Items	8
5	Cable Diagrams	13
6	Supported Devices.....	16
7	Device Code and Address Code.....	24
8	Error Messages.....	25

Introduction

This manual describes how to connect the Display and the External Device (target PLC).

In this manual, the connection procedure is described in the sections identified below:

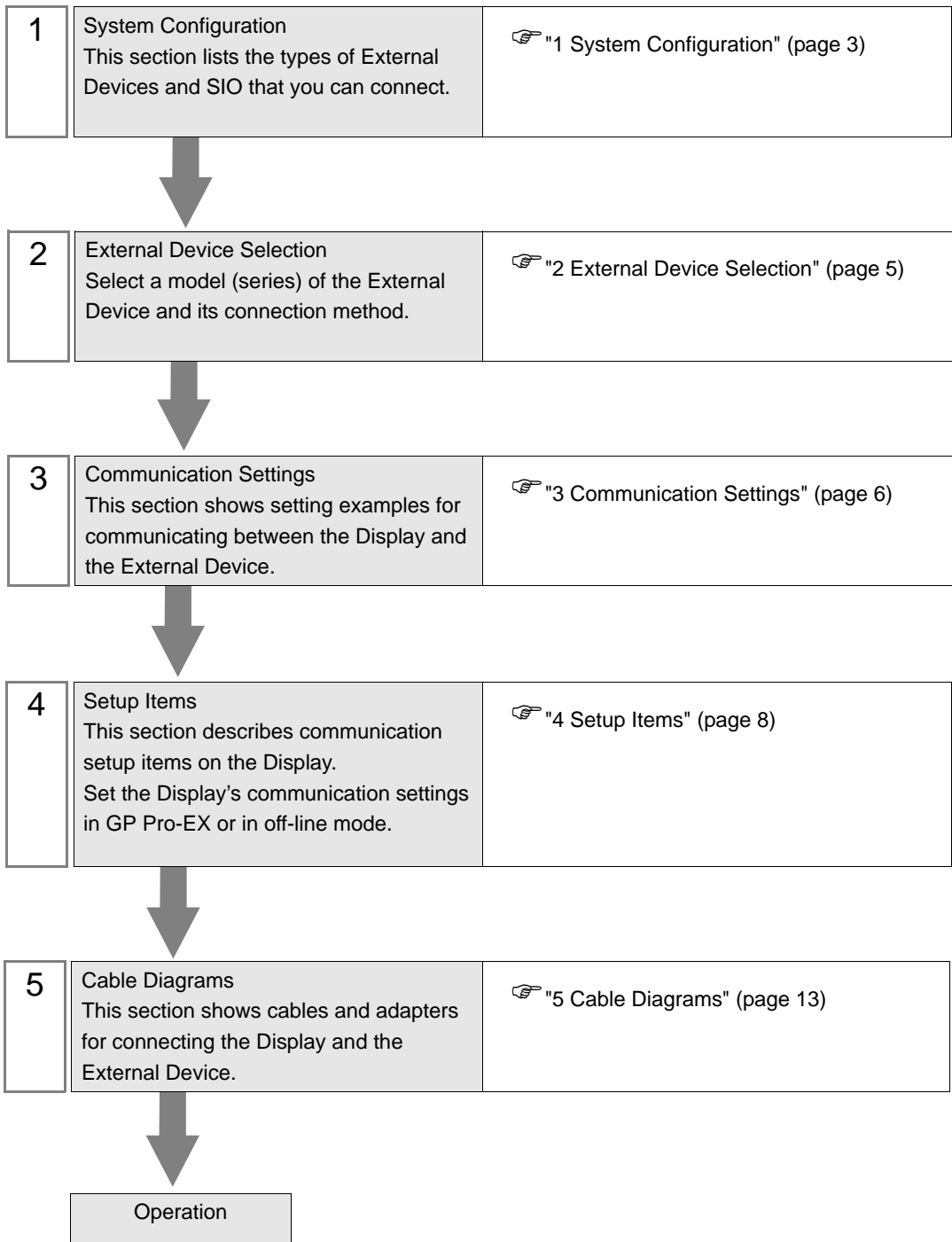

1 System Configuration

The following table lists system configurations for connecting CANopen master and the Display.

Series	CPU* ¹	Link I/F	Setting Example	Cable Diagram	SIO Type
GP3000	AGP3300-L1-D24-CA1M AGP3300-T1-D24-CA1M AGP3400-T1-D24-CA1M AGP3500-T1-D24-CA1M AGP3500-T1-AF-CA1M AGP3600-T1-D24-CA1M AGP3600-T1-AF-CA1M	CANopen Interface	"Setting Example 1" (page 6)	"Cable Diagram1" (page 14)	CANopen
LT3000	LT-3201A LT-3300S LT-3300L LT-3301L	CA8-CANLT-01	"Setting Example 1" (page 6)	"Cable Diagram1" (page 14)	
Premium	TSXP57103M TSXP57203M TSXP57253M TSXP572623M TSXP572823M TSXP57303AM TSXP573623AM TSXP57353LAM TSXP57353AM TSXP57453AM TSXP574823AM	TSXCPP110	"Setting Example 1" (page 6)	"Cable Diagram1" (page 14)	
Twido	TWD LMDA□0D□□ TWD LC□A 24DRF TWD LC□A 40DRF	TWDNC01M	"Setting Example 1" (page 6)	"Cable Diagram1" (page 14)	

*1 "□" varies depending on the External Device.

IMPORTANT

- To use a CANopen slave driver, you need a CANopen slave unit (CA9-CANALL/EX-01) for GP3000 series by Pro-face. For more information about the cable diagram between the Display (CANopen slave unit) and the CANopen master and about the CANopen slave unit, please refer to "CANopen Slave Unit Hardware Manual".

■ Connection Configuration

- CANopen Network

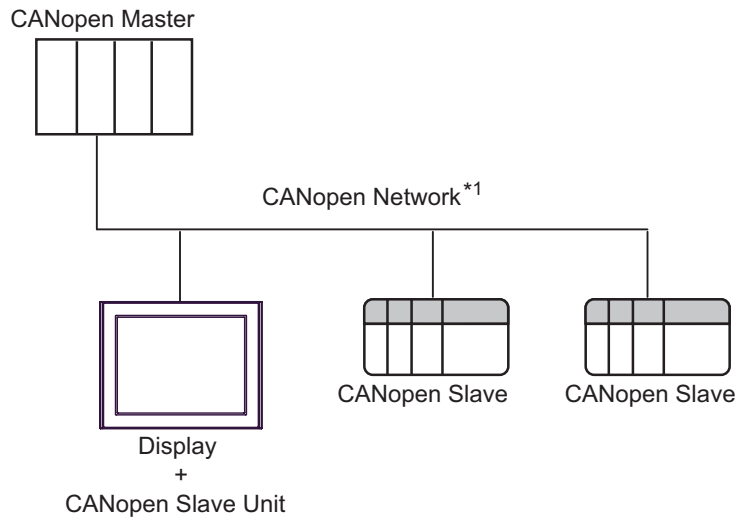

*1 The maximum number of connectable slaves is 127. However, the maximum number of connectable units differs depending on the master in use. Refer to the master External Device's manual for details.

◆ Communication Protocol

CANopen communicates using SDO and PDO.

SDO (Service Data Object) is used for Domain device communication.

Refer to the description below for setting of the domain object.

☞ "■ Device Setting" (page 9)

PDO (Process Data Object) is used for Input/Output device communication.

4PDO (16words) is set to the Input/Output device as default. When using a device exceeding 4PDO, the device needs to be set to valid by the CANopen master.

2 External Device Selection

Select the External Device to be connected to the Display.

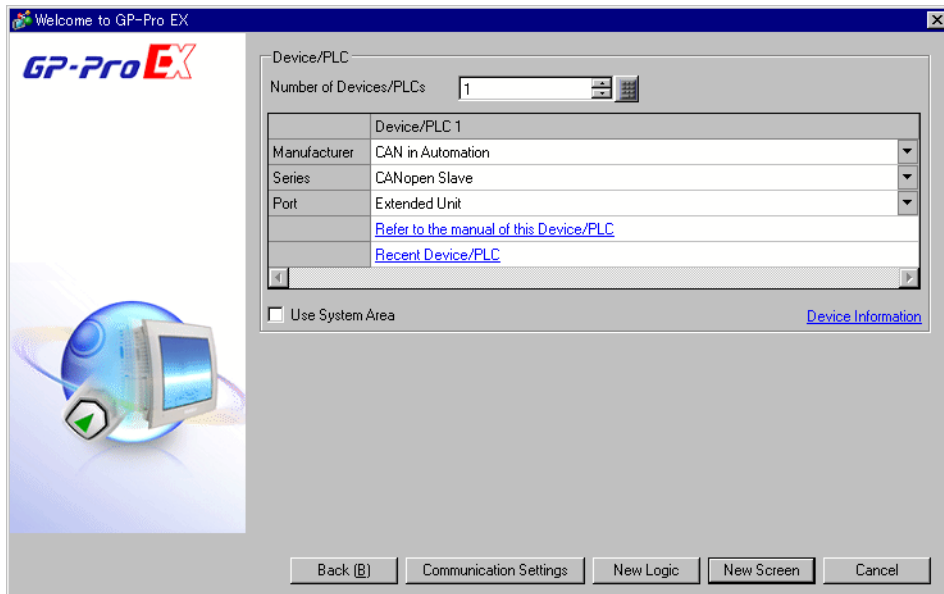

Setup Items	Setup Description
Number of Devices/PLCs	Use an integer from 1 to 4 to enter setting number of series.
Manufacturer	Select the manufacturer of the External Device to be connected. Select "CAN in Automation".
Series	Select a model (series) of the External Device to be connected and connection method. Select "CANopen Slave". In System configuration, check to make sure the external device to which you are connecting is supported in "CANopen Slave". ☞ "1 System Configuration" (page 3)
Port	Select the Display port to be connected to the External Device.
Use System Area	Check this option to synchronize the system data area of the Display and the device (memory) of the External Device. When synchronized, you can use the ladder program of the External Device to switch the display or display the window on the Display. Cf. GP-Pro EX Reference Manual "Appendix 1.4 LS Area (Direct Access Method)" This can be also set with GP Pro-EX or in the Display's off-line mode. Cf. GP-Pro EX Reference Manual "5.17.6 [System Settings] Setting Guide, [Display Unit] Settings Guide, System Area Settings" Cf. Maintenance/Troubleshooting Manual "2.15.1 Settings common to all Display models, [Main Unit Settings] Settings Guide, System Area Settings"

3 Communication Settings

This section provides examples of communication settings recommended by Pro-face for the Display and the External Device.

3.1 Setting Example 1

■ GP Pro-EX Settings

◆ Communication Settings

To display the setup screen, from the [System Settings] workspace, select [Device/PLC].

IMPORTANT



- Please import the EDS file to the master. The EDS file is stored in the [Fieldbus\canopns] folder on the GP-Pro EX CD-ROM. Or please download the EDS file from support site "Otasuke Pro!". Please refer to the manual of the External Device (master) for more details on how to use EDS files.

Pro-face's support site "Otasuke Pro!"
<http://www.pro-face.com/otasuke/>

NOTE

- Choose a Baud rate that your Bus length can support.
 ☞ "5 Cable Diagrams" (page 13)

◆ Device Setting

To display the [Individual Device Settings] dialog box, select the external device and click  [Settings] from [Device-Specific Settings] in the [Device/PLC] window. To connect multiple External Devices, click  from [Device-Specific Settings] in the [Device/PLC] window to add another External Device.

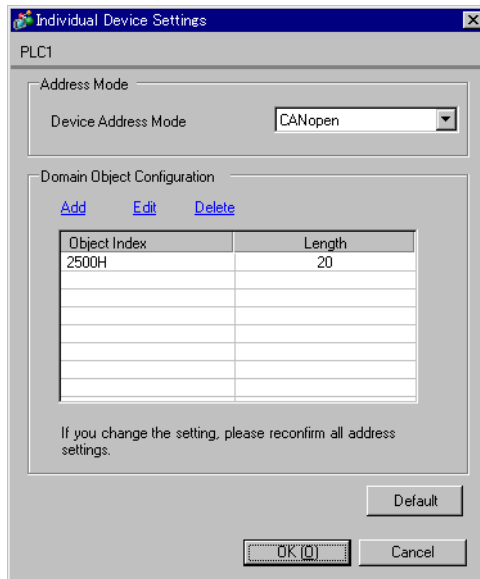

■ External Device Settings

Refer to your External Device manual for details.

4 Setup Items

Set up the Display's communication settings in GP Pro-EX or in the Display's off-line mode.

The setting of each parameter must match that of the External Device.

☞ "3 Communication Settings" (page 6)

4.1 Setup Items in GP Pro-EX

■ Communication Settings

To display the setup screen, from the [System Settings] workspace, select [Device/PLC].

Device/PLC 1

Summary [Change Device/PLC](#)

Manufacturer Series Port

Text Data Mode [Change](#)

Communication Settings

Node ID

Speed



Device-Specific Settings

Allowable Number of Devices/PLCs

Number	Device Name	Settings
<input type="text" value="1"/>	<input type="text" value="PLC1"/>	<input type="text" value="Device Address Mode=CANopen.DomainCount=1.Object Index=2500.Length=2"/>

Setup Items	Setup Description
Node ID	Use an integer from 1 to 127 to enter Node ID.
Speed	<p>Select communication speed between the External Device and the Display.</p> <p>NOTE</p> <p>When select "Auto", make sure there is a slave with fixed baud rate in the network. When the CANopen slave module cannot detect baud rate within five seconds, the error (RHxx145) is displayed.</p>

■ Device Setting

To display the [Individual Device Settings] dialog box, select the external device and click  [Settings] from [Device-Specific Settings] in the [Device/PLC] window. To connect multiple External Devices, click  from [Device-Specific Settings] in the [Device/PLC] window to add another External Device.

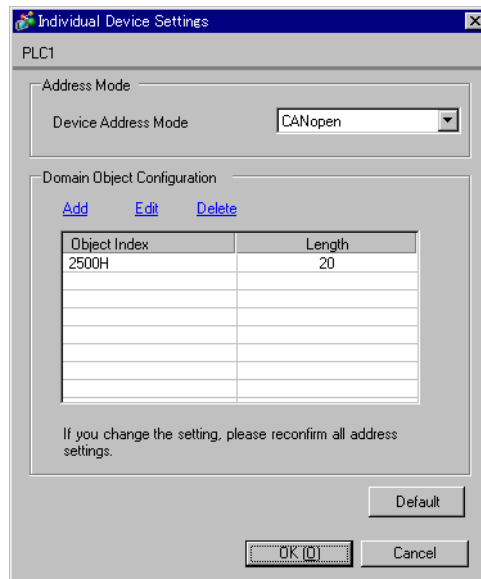

Setup Items	Setup Description
Address Mode	
Device Address Mode	Select the device address mode from “CANopen” or “IEC61131”.
Domain Object Configuration	
Add	Add domain objects. Up to 8 objects can be registered.
Edit	Use an integer from 1 to 512 words to enter the domain object length. IMPORTANT Input 2500H length using the “20 to 512” words. Set so that the domain object length in use becomes 3072 words or less in total.
Delete	Delete the domain object.
Object Index	Consecutive figure from 2500H is allocated to the domain object.
Length	Display the domain object length.

4.2 Setup Items in Off-line Mode

NOTE

- Refer to the Maintenance/Troubleshooting manual for information on how to enter off-line mode or about the operation.

Cf. Maintenance/Troubleshooting Manual "2.2 Off-line Mode"

■ Communication Settings

To display the setting screen, touch [Device/PLC Settings] from [Peripheral Equipment Settings] in off-line mode. Touch the External Device you want to set from the displayed list.

Comm.	Device			
CANopen Slave		Page 1/1		
Node ID	2 ▼ ▲			
Speed	250Kbps ▼			
Exit		Back		2009/03/15 17:32:45

Setup Items	Setup Description
Node ID	Use an integer from 1 to 127 to enter Node ID.
Speed	Select communication speed between the External Device and the Display. NOTE When select "Auto", make sure there is a slave with fixed baud rate in the network. When the CANopen slave module cannot detect baud rate within five seconds, the error (RHxx145) is displayed.

■ Device Setting

To display the setting screen, touch [Device/PLC Settings] from [Peripheral Equipment Settings]. Touch the External Device you want to set from the displayed list, and touch [Device].

(page 1/2)

Comm.	Device			
CANopen Slave			Page 1/5	
Device/PLC Name	[PLC1] ▼			
Address Mode	[CANopen] ▼			
				➔
	Exit		Back	2009/03/15 17:32:51

Setup Items	Setup Description
Device/PLC Name	Select the External Device to be set. The name of External Device is the one that is set with GP-Pro EX. (Initial value [PLC1])
Address Mode	Select the device address mode from “CANopen” or “IEC61131”.

(page 2/2)

Comm.	Device			
CANopen Slave		Page 2/5		
Device/PLC Name [PLC1]				
Domain Object 1				
Object Index(HEX) 2500				
Length(WORDS) 0020				
Domain Object 2				
Object Index(HEX) ----				
Length(WORDS) ----				
				← →
Exit		Back		2009/03/15 17:32:56

Setup Items	Setup Description
Device/PLC Name	Select the External Device to be set. The name of External Device is the one that is set with GP-Pro EX. (Initial value [PLC1])
Domain Object	
Object Index (HEX)	Display the object index. The object index cannot be changed in off-line mode.
Length (WORDS)	Display the domain object length. The length cannot be changed in off-line mode.

5 Cable Diagrams

The following cable diagrams may be different from cable diagrams recommended by CAN in Automation. Please be assured there is no operational problem in applying the cable diagrams shown in this manual.

- Please ground the FG pin of the External Device body. Use a grounding resistance of 100Ω 2mm² or thicker wire, or your country's applicable standard. Refer to your External Device manual for more details.
- Refer to the CANopen Slave Unit Hardware Manual and External Device manuals for details of the recommended connector and cable.

■ Recommended Connector and Cables

	Model No.	Manufacturer	Description
Recommended Cable Connector	XM2D-0901	<OMRON Co.>	DSUB 9-pin socket without termination resistance
	TSXCANKCDF180T	<Schneider Electric>	Straight connector with terminal selector switch attached
	TSXCANKCDF90T TSXCANKCDF90TP	<Schneider Electric>	Right-angled connector with terminal selector switch attached.
	VS-09-BU-DSUB/CAN	<PHOENIX CONTACT>	Connector with terminal block attached with terminal selector switch attached
	SUBCON-PLUS-CAN/AX	<PHOENIX CONTACT>	Straight connector with terminal selector switch attached
	SUBCON-PLUS-CAN/PG SUBCON-PLUS-CAN	<PHOENIX CONTACT>	Right-angled connector with terminal selector switch attached
CANopen Recommended Transfer Cable	TSX CAN CA50 TSX CAN CA100	<Schneider Electric>	Cable for CANopen (IEC60332-1) 50 m/100 m
	TSX CAN CB50 TSX CAN CB100	<Schneider Electric>	UL-authenticated cable for CANopen (IEC60332-2) 50 m/100 m

Cable Diagram1

Display (Connection Port)	Cable	Notes
GP*1 (Expansion unit)	CANopen slave unit by Pro-face CA9-CANALL/EX-01 + CANopen recommended cable	

*1 All GP models except GP-3200 series and CANopen master supported Display

NOTE

- Choose a Baud rate that your Bus length can support.

Baud rate	Bus length
1000 Kbps	20 m
800 Kbps	40 m
500 Kbps	100 m
250 Kbps	250 m
125 Kbps	500 m
50 Kbps	1000 m

- 1:1 Connection

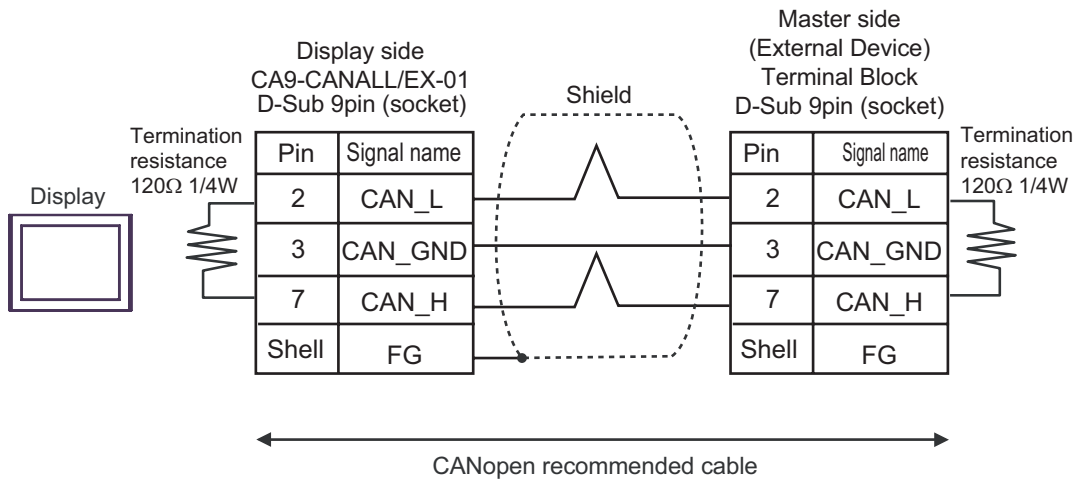

- 1:n Connection

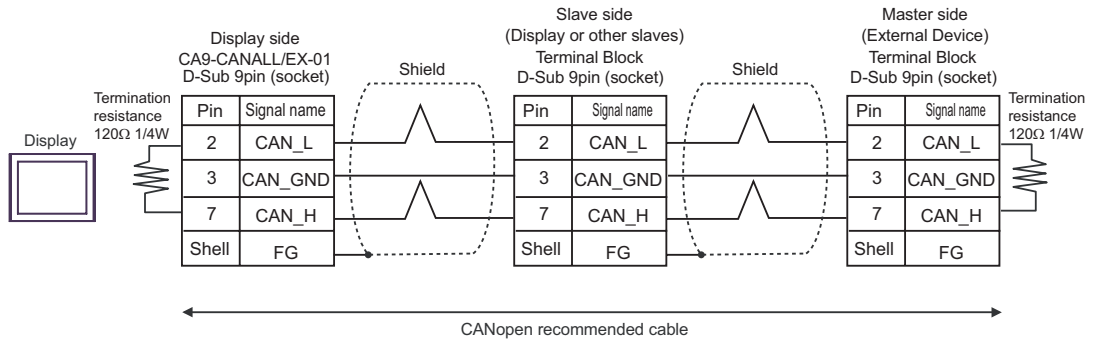
**IMPORTANT**

- Be sure to connect terminal resistors (120Ω 1/4W) at both ends of the cabling connections as shown above.

6 Supported Devices

The following table shows the range of supported device addresses. Please note that the actually supported range of the devices varies depending on the External Device to be used. Please check the actual range in the manual of your External Device.

 This address can be specified as system data area.

Device	Bit Address		Word Address		32bits	Notes
	IEC	CANopen	IEC	CANopen		
Input	%IX000.00 - %IX255.15	2000H000.00 - 2000H127.15 2010H000.00 - 2010H127.15	%IW000 - %IW255	2000H000 - 2000H127 2010H000 - 2010H127	L/H	*1*2
Output	%QX000.00 - %QX255.15	2100H000.00 - 2100H127.15 2110H000.00 - 2110H127.15	%QW000 - %QW255	2100H000 - 2100H127 2110H000 - 2110H127		*3
Diagnostics	-	-	DG000 - DG006	DG000 - DG006		*1*4
Domain1	%1DX000.00 - %1DX511.15	2500H000.00 - 2500H511.15	%1DW000 - %1DW511	2500H000 - 2500H511		*5
Domain2	%2DX000.00 - %2DX511.15	2501H000.00 - 2501H511.15	%2DW000 - %2DW511	2501H000 - 2501H511		*5
Domain3	%3DX000.00 - %3DX511.15	2502H000.00 - 2502H511.15	%3DW000 - %3DW511	2502H000 - 2502H511		*5
Domain4	%4DX000.00 - %4DX511.15	2503H000.00 - 2503H511.15	%4DW000 - %4DW511	2503H000 - 2503H511		*5
Domain5	%5DX000.00 - %5DX511.15	2504H000.00 - 2504H511.15	%5DW000 - %5DW511	2504H000 - 2504H511		*5
Domain6	%6DX000.00 - %6DX511.15	2505H000.00 - 2505H511.15	%6DW000 - %6DW511	2505H000 - 2505H511		*5
Domain7	%7DX000.00 - %7DX511.15	2506H000.00 - 2506H511.15	%7DW000 - %7DW511	2506H000 - 2506H511		*5
Domain8	%8DX000.00 - %8DX511.15	2507H000.00 - 2507H511.15	%8DW000 - %8DW511	2507H000 - 2507H511	*5	

*1 Write disabled.

*2 2000H and 2010H are displayed in succession in Address Map and Device Monitor.

*3 2100H and 2110H are displayed in succession in Address Map and Device Monitor.

*4 Refer to the description below for details.

 "◆ Diagnostics Device" (page 17)

*5 Set so that the domain object length in use becomes 3072 words or less in total.

◆Diagnostics Device

Refer to the table below for details of the diagnostics device.

Address	Name	Comment
0	COMM_STATUS	MSB = Communication state machine, LSB= State of the communication with the network
1	EVENT_BITS	Event indication bits
2	CONFIG_BITS	Configuration bits
3	RED_LED_STATUS	Status of the error LED (red LED)
4	GRN_LED_STATUS	Status of the run LED (green LED)
5	BAUD_RATE	Configured baud rate
6	FW_VERSION	Firmware version of the CA9-CANALL/EX-01 module

COMM_STATUS

LSB and MSB comprise the COMM_STATUS field.

Refer to the table below for details.

- LSB

LSB of the COMM_STATUS	Description
0x00	Initializing the CANopen stack. Automatically goes to 0x41 when initialization is done.
0x41	Received a STOP command from master, CANopen slave is stopped.
0x42	Lost connection with master or waiting for master, CANopen slave is pre-operational.
0x43	CANopen slave is operational.
0x90	CANopen slave is in fatal error situation. CANopen slave can not proceed until error situation is resolved.

- MSB

Bit	Description
0	Quantity of the low-priority receive data is over range.
1	Quantity of the CAN controller data is over range.
2	The CAN controller is bus off
3	The CAN controller is in an error state. This bit is reset when the error state is ended.
4	The CAN controller is not in an error state. An error history caused by stack will not be reset.
5	Quantity of the low-priority transmit data is over range.
6	Quantity of the high-priority receive data is over range.
7	Quantity of the high-priority transmit data is over range.

EVENT_BITS

Refer to the table below for details.

Bit	Description
0	Fatal error state
1	Not used
2	Not used
3	Not used
4	Not used
5	Not used
6	Not used
7	Display the changed value of Event_bits.
8	Not used
9	The size of RPDO received by CANopen master/manager is invalid.
10	Not used
11	Size of the SDO communication data is over range.
12	Not used
13	Network connection not found. Not connected to network.
14	Not used
15	Not used

CONFIG_BITS

Refer to the table below for details.

Bit	Description
0	Module is configured as slave. (Should always be 0)
1	Slave starts up individually. (Should always be 0)
2	The CANopen slave starts up. (Should always be 1)
3	Only master can set communication status to operational. (Should always be 0)
4	Not used
5	Not used
6	Not used
7	CANopen slave is configured as consumer. (Should always be 0)

LED STATUS

Refer to the table below for details.

Value	LED status
0	LED off
1	LED on
2	Flicker
3	Blink
4	Single flash
5	Double flash
6	Triple flash
7	Quadruple flash

BAUD_RATE

Refer to the table below for details.

Value	Baud rate
0	1000 Kbps
1	800 Kbps
2	500 Kbps
3	250 Kbps
4	125 Kbps
6	50 Kbps

FW_VERSION

Display the CANopen slave unit's firmware version.

◆Object Dictionary

Refer to the table below for details of the object dictionary.

Index (Hex)	Sub Index	Name	Type
1000		Device Type	VAR
1001		Error register	VAR
1003		EMCY message object	ARRAY
	0	Number of errors	
	1	EMCY field 1	
	2	EMCY field 2	
1005		COB-ID SYNC	VAR
1008		manufacturer device name	VAR
1009		Manufacturer hardware version	VAR
100A		Manufacturer software version	VAR
1010		Store parameters	ARRAY
	0	largest subindex supported	
	1	save all parameters	
1011		Restore default parameters	ARRAY
	0	Number of entries	
	1	parameters that can be restored	
1014		COB-ID for EMCY message	VAR
1015		Inhibit time for EMCY message	VAR
1016		Consumer heartbeat time	ARRAY
	0	Number of entries	
	1	Consumer heartbeat time	
1017		Producer heartbeat time	VAR
1018		Identity object	RECORD
	0	Number of entries	
	1	Vendor ID	
	2	Product code	
	3	Revision number	
1020		Verify Configuration	ARRAY
	0	Number of entries	
	1	Configuration date	
	2	Configuration time	
1200		1. Server SDO	VAR
	0	Number of entries	
	1	COB-ID Client → Server (Rx)	

Continued

Index (Hex)	Sub Index	Name	Type
	2	COB-ID Server → Client (Tx)	
1400 1403		Receive PDO	RECORD
	0	Number of entries	
	1	COB-ID	
	2	Transmission type of RxPDO	
1404 143F		Receive PDO	RECORD
	0	Number of entries	
	1	COB-ID	
	2	Transmission type of RxPDO	
1600 161F		Receive PDO mapping	RECORD
	0	Number of entries	
	1	PDO mapping for the 1st application object to be mapped	
	2	PDO mapping for the 2nd application object to be mapped	
	3	PDO mapping for the 3rd application object to be mapped	
	4	PDO mapping for the 4th application object to be mapped	
1620 163F		Receive PDO mapping	RECORD
	0	Number of entries	
	1	PDO mapping for the 1st application object to be mapped	
	2	PDO mapping for the 2nd application object to be mapped	
	3	PDO mapping for the 3rd application object to be mapped	
	4	PDO mapping for the 4th application object to be mapped	
1800 1803		Transmit PDO	RECORD
	0	Number of entries	
	1	COB-ID	
	2	Transmission Type of TxPDO	
	3	Inhibit time	
	4	Reserved	

Continued

Index (Hex)	Sub Index	Name	Type
	5	Event timer	
1804 183F		Transmit PDO	RECORD
	0	Number of entries	
	1	COB-ID	
	2	Transmission Type of TxPDO	
	3	Inhibit time	
	4	Reserved	
	5	Event timer	
1A00 1A1F		Transmit PDO mapping	RECORD
	0	Number of entries	
	1	PDO mapping for the 1st application object to be mapped	
	2	PDO mapping for the 2nd application object to be mapped	
	3	PDO mapping for the 3rd application object to be mapped	
	4	PDO mapping for the 4th application object to be mapped	
1A20 1A3F		Transmit PDO mapping	RECORD
	0	Number of entries	
	1	PDO mapping for the 1st application object to be mapped	
	2	PDO mapping for the 2nd application object to be mapped	
	3	PDO mapping for the 3rd application object to be mapped	
	4	PDO mapping for the 4th application object to be mapped	
1F80		NMTStartup	VAR
2000		Word Output	ARRAY
	0	Number of entries	
	1	1st output word	
	...		
	128	128th output word	
2010		Word Output	ARRAY
	0	Number of entries	

Continued

Index (Hex)	Sub Index	Name	Type
	1	1st output word	
	...		
	128	128th output word	
2100		Word Input	ARRAY
	0	Number of entries	
	1	1st input word	
	...		
	128	128th input word	
2110		Word Input	ARRAY
	0	Number of entries	
	1	1st input word	
	...		
	128	128th input word	
2500	0	Length is user defined (>20)	DOMAIN
2501	0	Length is user defined	DOMAIN
2502	0	Length is user defined	DOMAIN
2503	0	Length is user defined	DOMAIN
2504	0	Length is user defined	DOMAIN
2505	0	Length is user defined	DOMAIN
2506	0	Length is user defined	DOMAIN
2507	0	Length is user defined	DOMAIN
5000		Slave Diagnostics	ARRAY
	1	Global events	
	2	Slave network status	
	3	Communication status	
5FFF		Schneider specific object	RECORD
	0	Number of entries	
	1	Company name	
	2	Manufacturer Brand	
	3	Conformance class	

NOTE

- Please refer to the GP Pro-EX Reference Manual for System Data Area information.
Cf. GP Pro-EX Reference Manual "Appendix 1.4 LS Area (Direct Access Method)"
- Refer to the precautions on manual notation for icons in the table.

 "Manual Symbols and Terminology"

7 Device Code and Address Code

Use device codes and address codes when you set "Device Type & Address" for the address type of the data display or other devices.

Device	Device Name		Device Code (HEX)	Address Code
	IEC	CANopen		
Input	%IW	2000H	0080	Word address
		2010H		
Output	%QW	2100H	0081	Word address
		2110H		
Diagnostics	DG	DG	0060	Word address
Domain1	%1DX	2500H	0082	Word address
Domain2	%2DX	2501H	0083	Word address
Domain3	%3DX	2502H	0084	Word address
Domain4	%4DX	2503H	0085	Word address
Domain5	%5DX	2504H	0086	Word address
Domain6	%6DX	2505H	0087	Word address
Domain7	%7DX	2506H	0088	Word address
Domain8	%8DX	2507H	0089	Word address

8 Error Messages

Error messages are displayed on the Display screen as follows: "No. : Device Name: Error Message (Error Occurrence Area)". Each description is shown below.

Item	Description
No.	Error number
Device Name	Name of the External Device where an error has occurred. Device/PLC name is the title of the External Device set with GP Pro-EX. (Initial value [PLC1])
Error Message	Displays messages related to an error that has occurred.
Error Occurrence Area	<p>Displays the IP address or device address of the External Device where an error has occurred, or error codes received from the External Device.</p> <p>NOTE</p> <ul style="list-style-type: none"> • IP address is displayed as "IP address (Decimal): MAC address (Hex)". • Device address is displayed as "Address: Device address". • Received error codes are displayed as "Decimal [Hex]".

Examples of Error Messages

"RHAA035:PLC1: Error has been responded for device write command (Error Code: 2 [02H])"

NOTE

- Refer to your External Device manual for details on received error codes.
- Refer to "When an error is displayed (Error Code List)" in "Maintenance/Troubleshooting Manual" for details on the error messages common to the driver.

■ Error Messages Unique to External Device

Message ID	Error Message	Description
RHxx128	CANopen Slave module initialization error	CANopen slave module does not respond to Startup command from driver.
RHxx131	CANopen bus off detected	Check the parameter setting and cable length.
RHxx132	No network connection found	CANopen slave is not connected to the network.
RHxx136	Initialization command received from network.	CANopen master transmitted an INIT command.
RHxx137	STOP command received from network	CANopen master transmitted an STOP command.
RHxx144	CANopen slave has been switched to pre-operational mode.	CANopen master transmitted an RESET command.
RHxx145	Not able to detect baudrate	Communication speed cannot be detected within the set time.
RHxx146	Fatal error: CANopen slave module is not responding [I/O]	Firmware error. Restart the system.
RHxx147	Waiting for START command from network.	Slave is not registered with the master.

Continued

Message ID	Error Message	Description
RHxx148	[External Device name]:[Device name] Domain object is not configured	Invalid read/write was executed from the Domain object.
RHxx149	[External Device name]:[Device name] Domain has out of range devices	Invalid read/write. Domain object address was out of range.