

# Device/PLC Connection Manuals

---



## About the Device/PLC Connection Manuals

Prior to reading these manuals and setting up your device, be sure to read the "Important: Prior to reading the Device/PLC Connection manual" information. Also, be sure to download the "Preface for Trademark Rights, List of Units Supported, How to Read Manuals and Documentation Conventions" PDF file. Furthermore, be sure to keep all manual-related data in a safe, easy-to-find location.

## 12.3 Yamatake Controllers

### 12.3.1 System Structure



This chapter describes the system configuration used when connecting this Controller to the GP/GLC/LT.





- **GP/GLC/LT's System Area (LS0 to LS19) Settings**

*The GP/GLC/LT's system area (20 words) cannot be allocated to the Controller's own data area. Even though you can enter the system area settings via the GP's screen editor software or via the GP/GLC/LT's OFFLINE screen, it is impossible to actually allocate the system area to the Controller's data area.*



■ **SDC Series (1:1 communication)**

Controller	Cable Diagram	GP/GLC/LT
		
SDC 20 SDC 21 SDC 40A SDC 40B SDC 40G	RS-232C <Cable Diagram 1>	GP Series GLC Series LT Type C
SDC 20 SDC 21 SDC 30 SDC 31	RS-422 (4 wires) <Cable Diagram 2>	
SDC 40A SDC 40B SDC 40G	RS-422 (2 wires) <Cable Diagram 3>	



■ **SDC Series** (1:n (multi-drop) communication)

CPU	Cable Diagram	GP/GLC/LT
		
SDC 20 SDC 21 SDC 30 SDC 31 SDC 40A SDC 40B SDC 40G	RS-422 (4 wires) <Cable Diagram 4>	GP/GLC Series LT Type C
	RS-422 (2 wires) <Cable Diagram 5>	

■ **DMC10** (1:1 communication)

CPU	Cable Diagram	GP/GLC/LT
		
DMC10	RS-422 (2 wires) <Cable Diagram 6>	GP/GLC Series LT Type C

■ **DMC10** (1:n (multi-drop) communication)

CPU	Cable Diagram	GP/GLC/LT
		
DMC10	RS-422 (2 wires) <Cable Diagram 7>	GP/GLC Series LT Type C

**12.3.2 Cable Diagrams**

The cable diagrams shown below and those recommended by Yamatake may differ, however, using these cables for Controller's operations will not cause any problems.



- **When connecting the FG terminal to the connector cover, be sure that the connector cover material is conductive.**
- **Ground the Controller's FG terminal according to your country's applicable standard. For details, refer to your Controller's manual.**
- **When connecting a cable's shield line to an FG terminal, consider the needs of your system when deciding which side of the cable (GP/GLC or Controller) to connect. (The example below connects to the Controller's FG terminal.)**
- **The maximum RS-232C cable length is 15 meters. If a communication cable is used, be sure to connect its SG (signal ground) terminal.**
- **The maximum RS-422 cable length is 500 meters.**
- **The recommended RS-422 cables are as follows:**

**Recommended Cables**

Company		Type
Fujikura Densen	2 wires	IPEV-S-0.9mm <sup>2</sup> ×1P
	3 wires	ITEV-S-0.9mm <sup>2</sup> ×1T
Hitachi Densen	2 wires	KPEV-S-0.9mm <sup>2</sup> ×1P
	3 wires	KTEV-S-0.9mm <sup>2</sup> ×1T

- **Since the Controller's terminal numbers will differ depending on the type of additional functions, check these numbers with the Controller's appropriate manual.**

**Cable Diagram 1 (1:1) (RS-232C)**

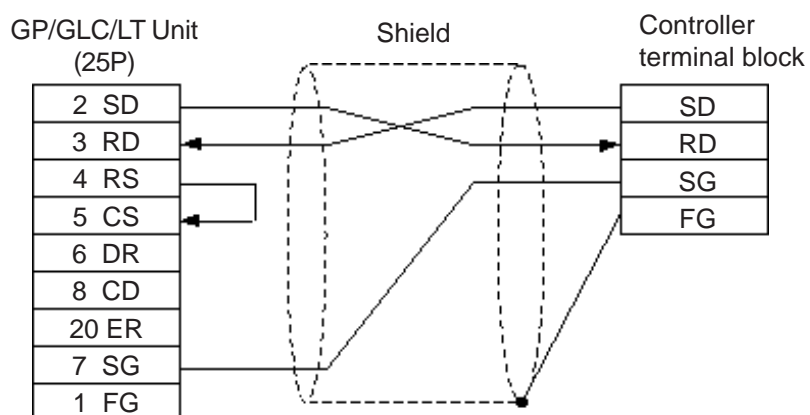

**Cable Diagram 2 (1:1) RS-422 4 Wires, RS-422 5 Wires**

<When using Digital's RS-422 connector terminal adapter GP070-CN10-0>

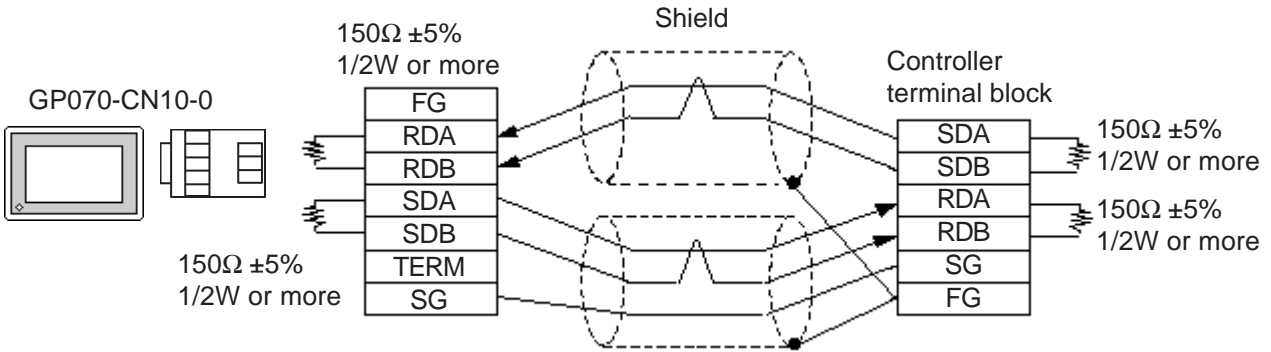

<When using Digital's RS-422 cable GP0230-IS11-0>

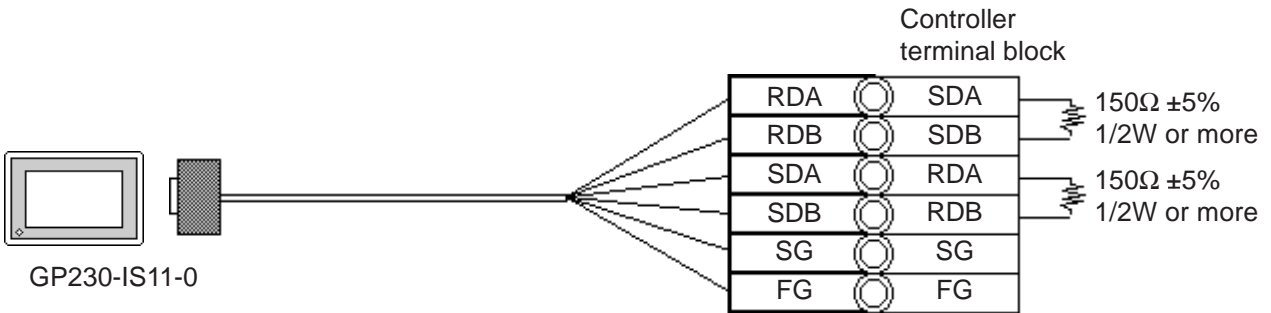

<When making your own cable>

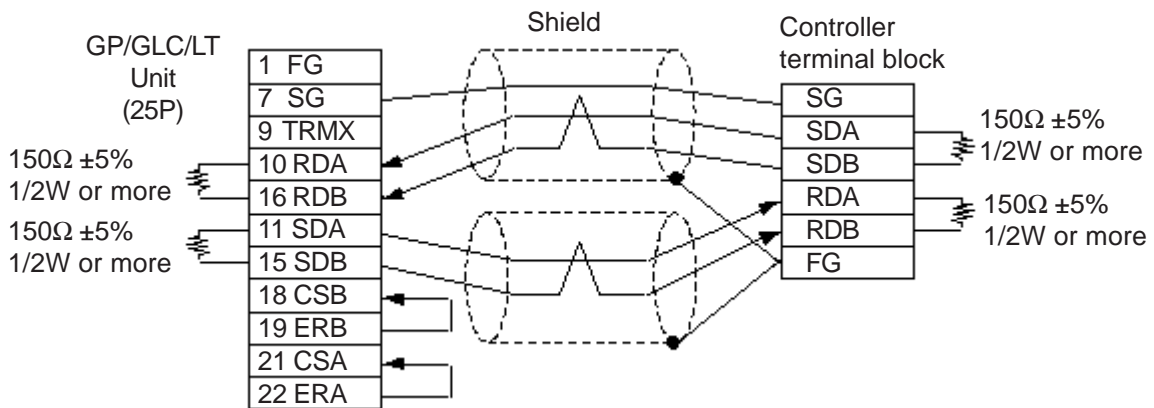

**Cable Diagram 3 (1:1) RS-422 2 Wires, RS-422 3 Wires**

<When using Digital's RS-422 connector terminal adapter GP070-CN10-0>

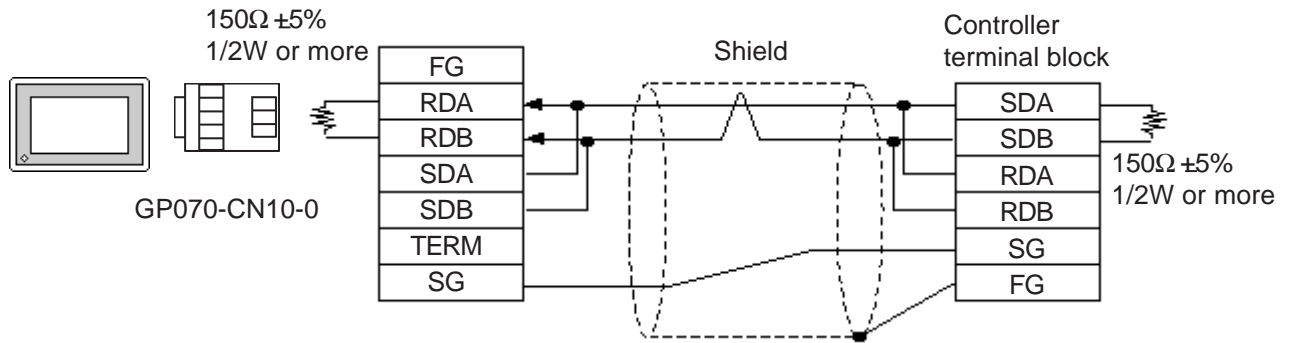

<When using Digital's RS-422 cable GP230-IS11-0>

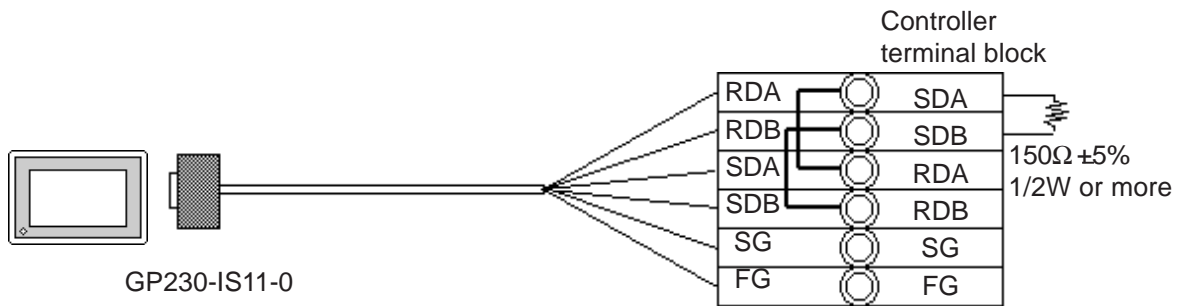

<When making your own cable>

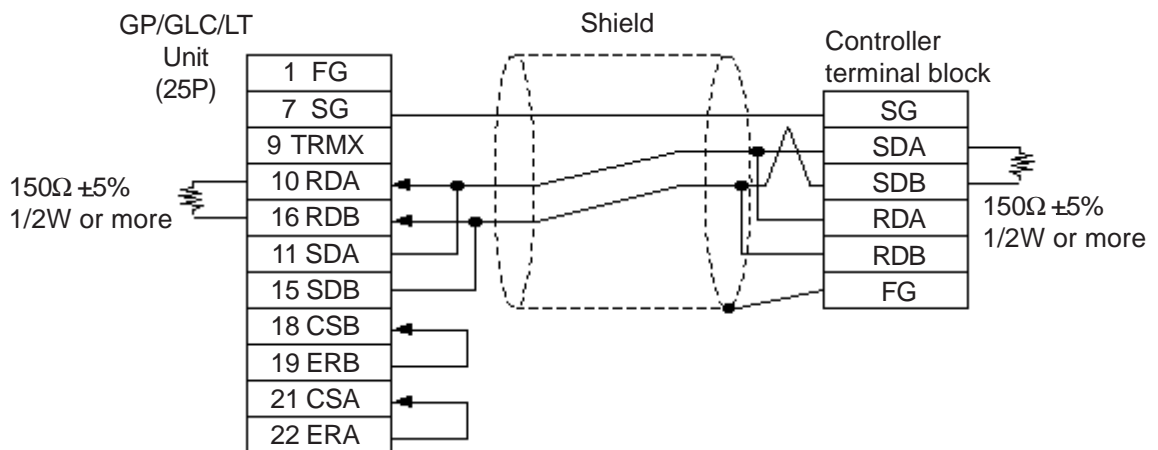

**Cable Diagram 4 (1:n) RS-422 4 Wires, RS-422 5 Wires**

<When using Digital's RS-422 connector terminal adapter GP070-CN10-0>

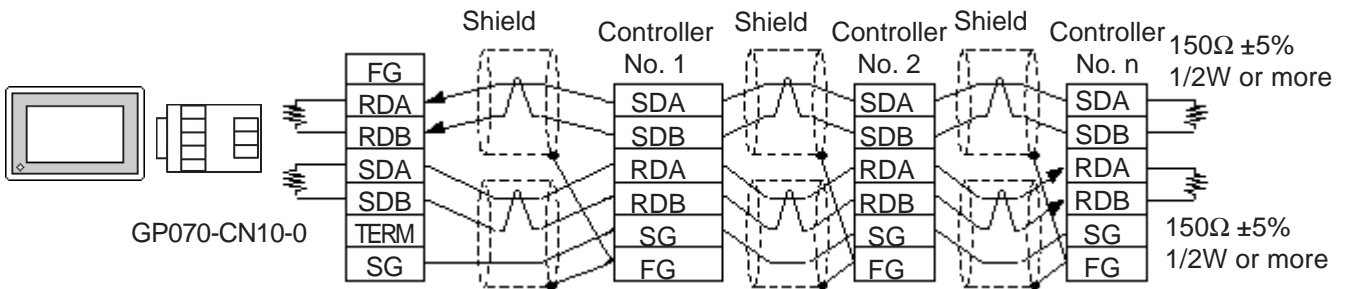

<When using Digital's RS-422 cable GP230-IS11-0>

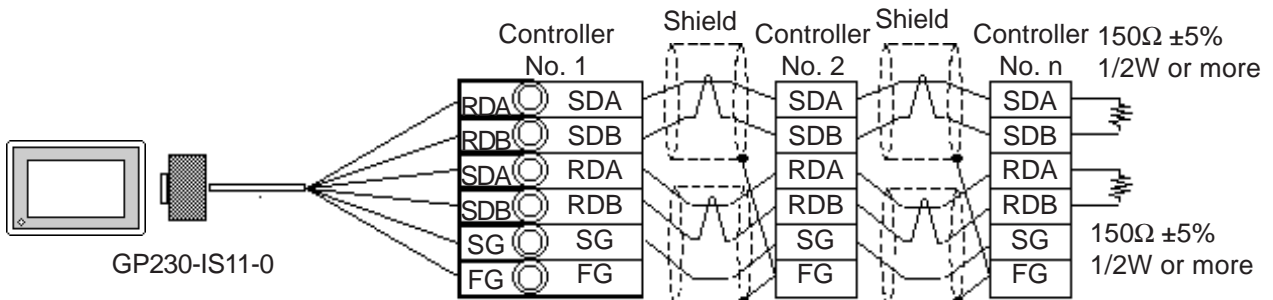

<When making your own cable>

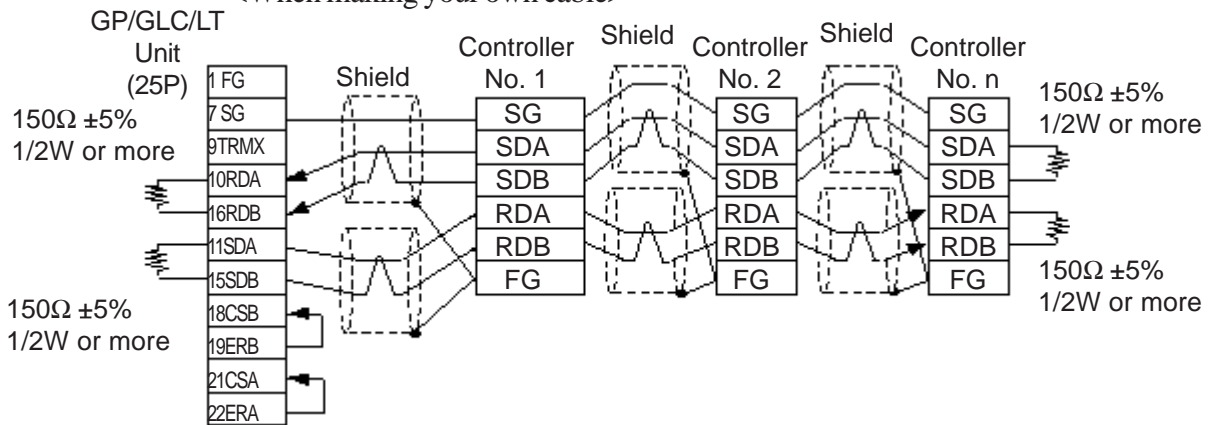

**Cable Diagram 5 (1:n) RS-422 2 Wires, RS-422 3 Wires**

<When using Digital's RS-422 connector terminal adapter GP070-CN10-0>

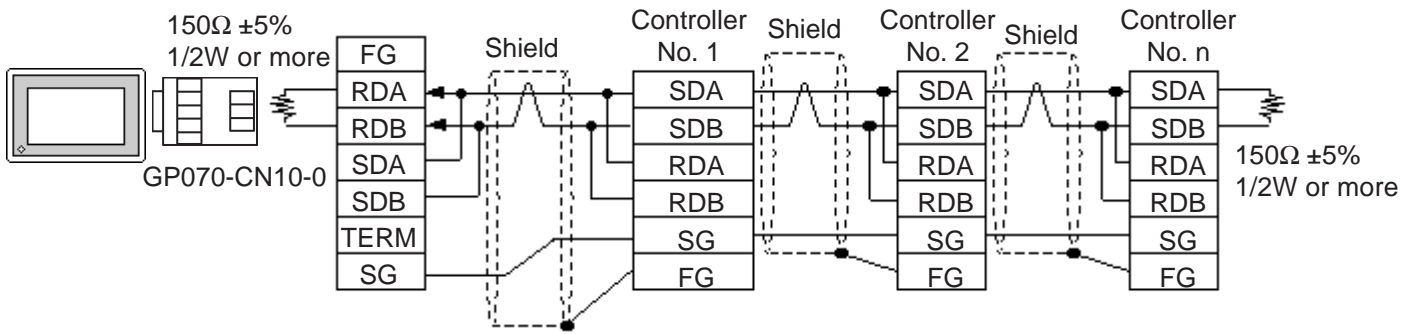

<When using Digital's RS-422 cable GP230-IS11-0>

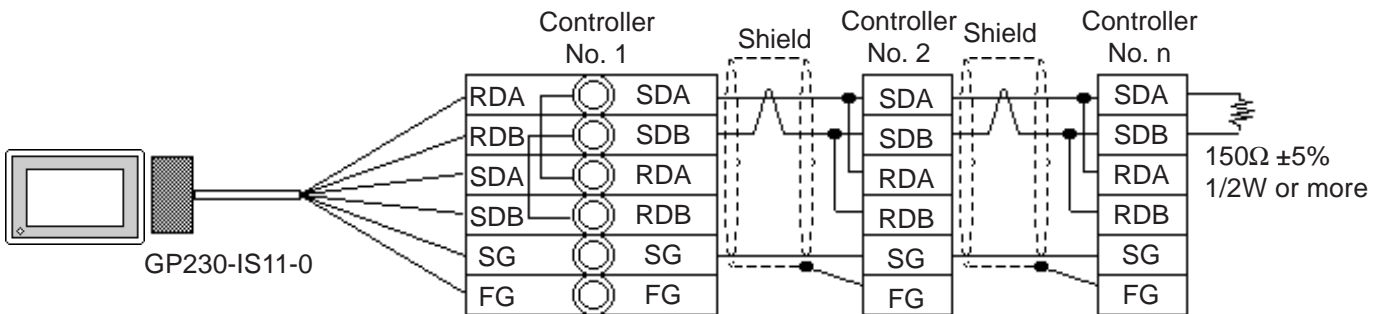

<When making your own cable>

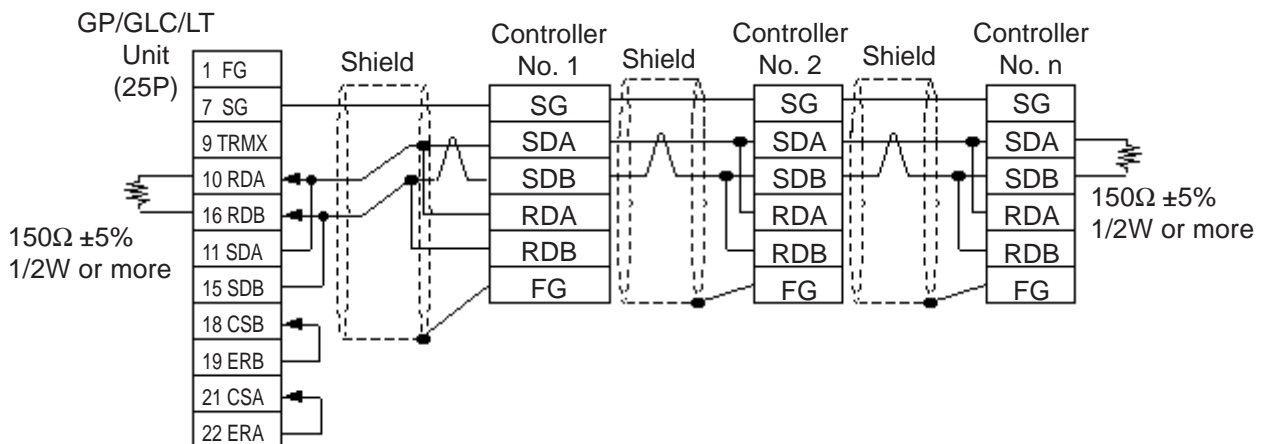



**Cable Diagram 6** (1:1) RS-422 2 Wires, RS-422 3 Wires

<When using Digital's RS-422 connector terminal adapter GP070-CN10-0>

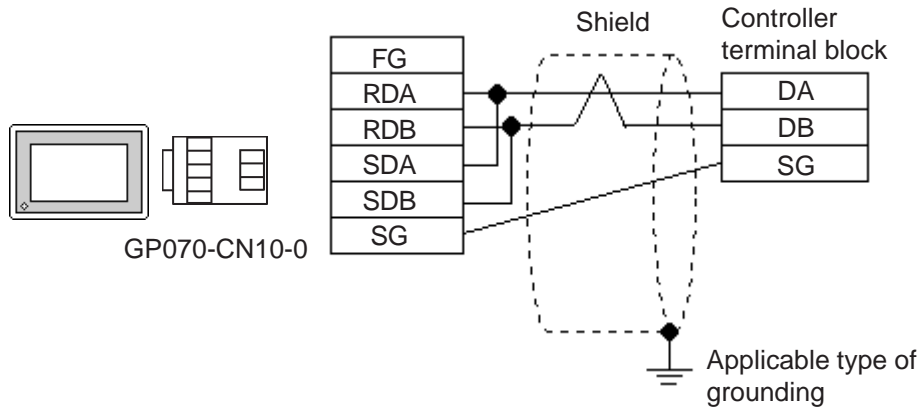

<When making your own cable>

GP/GLC/LT (25P, male)

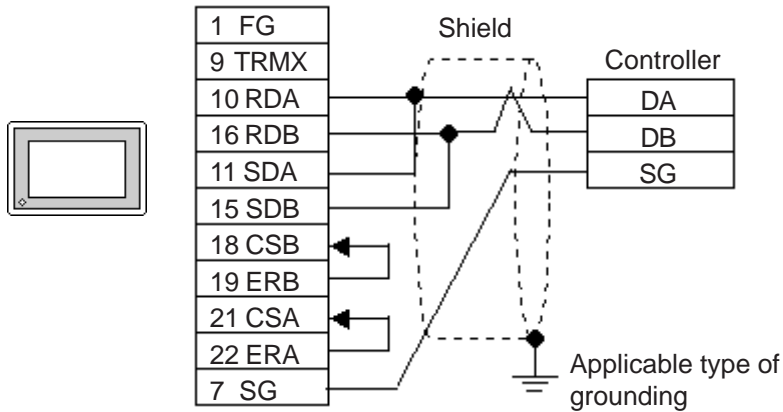

- **Since terminating resistance is provided inside the Controller, DO NOT connect additional terminating resistance.**

**Cable Diagram 7 (1:n) RS-422 2 Wires, RS-422 3 Wires**

<When using Digital's RS-422 connector terminal adapter GP070-CN10-0>

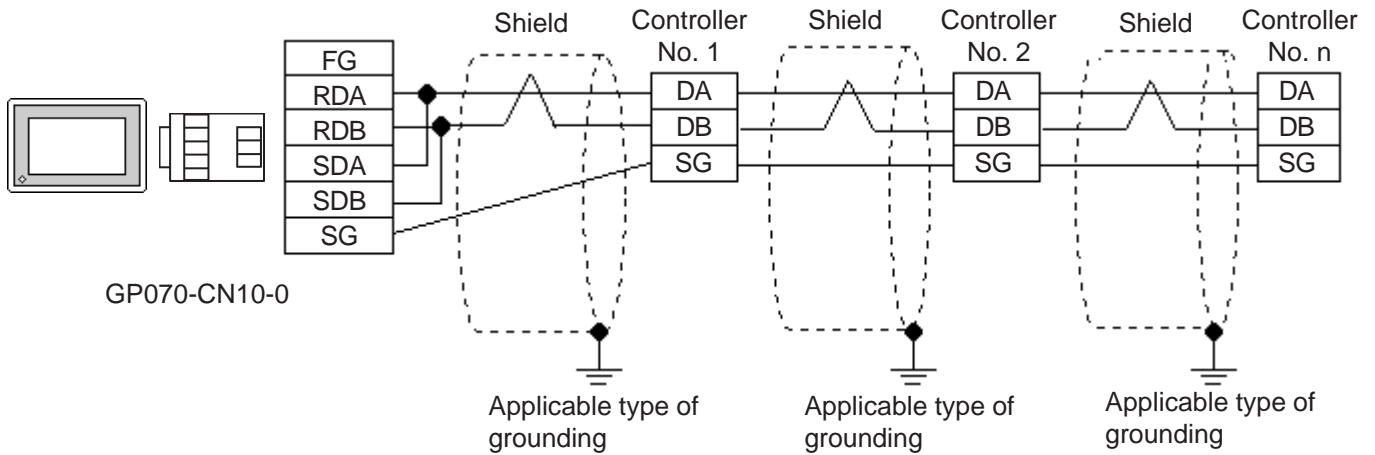

<When making your own cable>

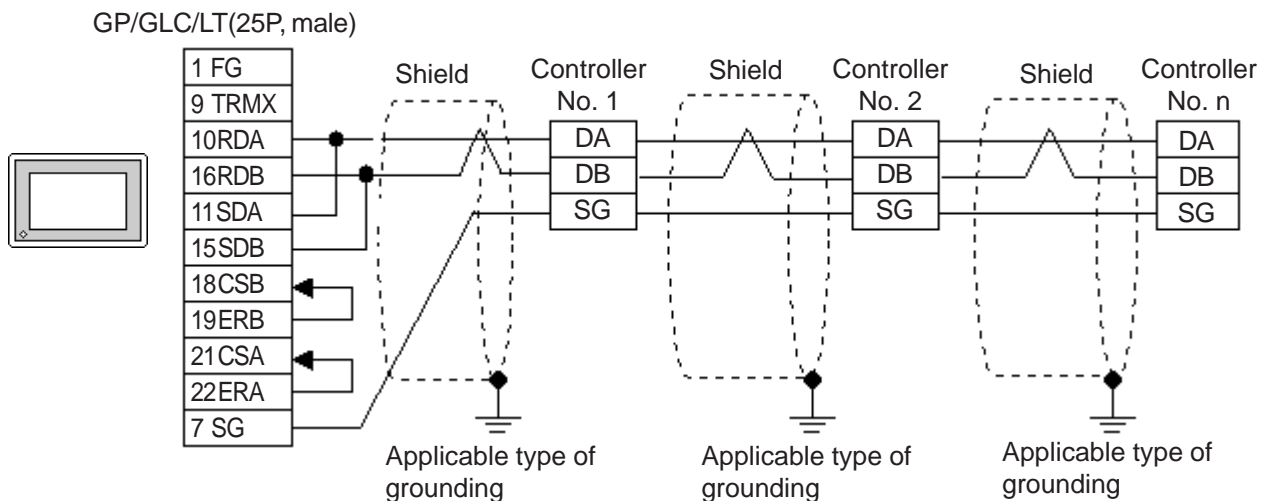

- **Since terminating resistance is provided inside the Controller, DO NOT connect additional terminating resistance.**

**12.3.3 Supported Devices**

The following lists show the ranges of devices supported by the GP/GLC/LT.

■ **SDC Series**

Device	Bit Address	Word Address	Remarks
Data	00000 ~ 8999F	0000 ~ 8999	L/H

■ **DMC10\*1**

Device	Bit Address	Word Address	Remarks
Data	10010 ~ 7804F	1001 ~ 7804	L/H

\*1. Data cannot be written or read to some Addresses. For more detailed information, refer to the Yamatake's appropriate Operation manual.



• **GP/GLC's System Data Area (LS0 to LS19) Settings**

*The GP/GLC/LT's system area (20 words) cannot be allocated to the Controller's own data area. Even though you can enter the system area settings via the GP screen editor software or via the GP/GLC/LT's OFFLINE screen, it is impossible to actually allocate the system area to the Controller's data area.*

- *Be careful that the Device fields differ depending on the type of Controller. Refer to the Controller's manual for the range allowed for the device address area.*

*After screen data is converted from a different type of Controller, be sure to check if the device addresses used are correct.*

*Be sure to check the supported device addresses before using Trend graphs or tags in your screens that use multiple words over continuous addresses.*



- When entering device addresses via the GP screen editor software, the top address (left-most digit) is used for the device name and remaining three digits (0 to 999) are used for the Controller data addresses.
- When settings tags in the screen editor software, the device address can be designated during address input. When a device number is not designated, the previously entered device number is automatically used. (The default value is 1.)

<e.g.> When entering Device Address "6728":

Enter the device name "6", and then the Word Address "728".

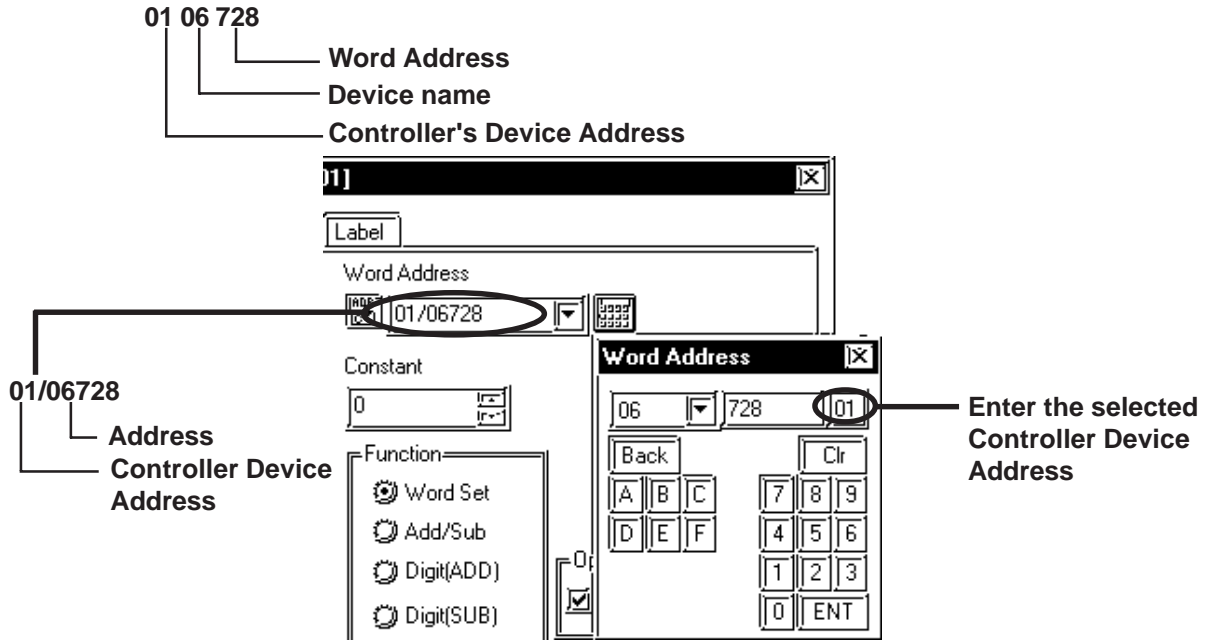

**12.3.4 Environment Setup**

The following tables show Digital's recommended Controller and GP/PLC communication settings.

**■ SDC Series**

GP/GLC/LT Settings		Controller Settings	
Baud Rate	9600bps	Baud Rate	9600bps
Data Length	8bit	Data Length	8bit
Stop Bit	1bit	Stop Bit	1bit
Parity Bit	Even	Parity Bit	Even
Data Flow Control	ER	-----	-----
Communication Format (when using RS-232C *1)	RS-232C	-----	-----
Communication Format (when using RS-422)	4 wires	-----	-----
Communication Format (when using RS-422)	2 wires	-----	-----
Unit No.	Select a desired unit number from 1 to 32.	Device Address	Enter all different Controller device addresses.

\*1 RS-232C communication can be performed with SDC20, SDC21, SDC40A, SDC40B, and SDC40G.



- **Although the Controller's device address input range is from 0 to 127, be sure to use only from 1 to 32 on the GP/GLC/LT to match the Controller's device address to the GP's.**
- **When using 1:n communication, up to 31 Controllers can be connected.**
- **When the device address is designated as 0 (default value), communication is not be performed.**

**■ DMC10**

GP/GLC/LT Settings		Controller Settings	
Baud Rate	19200bps	Baud Rate	19200bps
Data Length	8bit	Data Length	8bit
Stop Bit	1bit	Stop Bit	1bit
Parity Bit	Even	Parity Bit	Even
Data Flow Control	ER	-----	-----
Communication Format (when using RS-422)	2 wires	-----	-----
Unit No. *2	Select a desired unit number from 1 to 15.	Device Address	Enter all different Controller device addresses (1 to F).

\*2 Unit numbers entered on the GLC are decimal numbers.