

Device/PLC Connection Manuals



About the Device/PLC Connection Manuals

Prior to reading these manuals and setting up your device, be sure to read the "Important: Prior to reading the Device/PLC Connection manual" information. Also, be sure to download the "Preface for Trademark Rights, List of Units Supported, How to Read Manuals and Documentation Conventions" PDF file. Furthermore, be sure to keep all manual-related data in a safe, easy-to-find location.

2.11 Toshiba Machine

2.11.1 System Structure



The following describes the system structure for connecting the GP to Toshiba Machine PLCs.

Reference The Cable Diagrams mentioned in the following tables are listed in the section titled "2.11.2 Cable Diagrams".

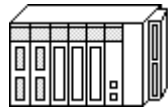

Note: Match up the GP Unit No. and each PC Number when multiple PCs are connected using PC Link.

■ PROVISOR TC200 Series (using Link I/F)

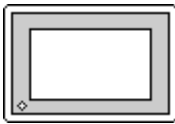
CPU	Link I/F	Cable Diagram	GP
	 SIO Module		
TCCUH	TCCMW TCCMO Link I/F on CPU *1	RS-232C (Cable Diagram 1)	GP Series
TCCUHS TCCUSS	RS-232C connector on CPU module TCCMWA TCCMOA	RS-232C (Cable Diagram 2)	

*1 Connect to the RS-232C connector.

2.11.2 Cable Diagrams

The cable diagrams illustrated below and the cable diagrams recommended by Toshiba Machine may differ, however, using these cables for your PLC operations will not cause any problems.



Ground your PLC's FG terminal according to your country's applicable standard. For details, refer to the corresponding PLC manual.



- **Connect the FG line of the Shield cable to either the GP or PLC, depending on your environment. When using a connector hood and grounding the FG line, be sure to use an electrical conductor.**
- **For the RS-232C connection, use a cable length less than 15m.**
- **If a communications cable is used, it must be connected to the SG (signal ground).**

Cable Diagram 1 (RS-232C)

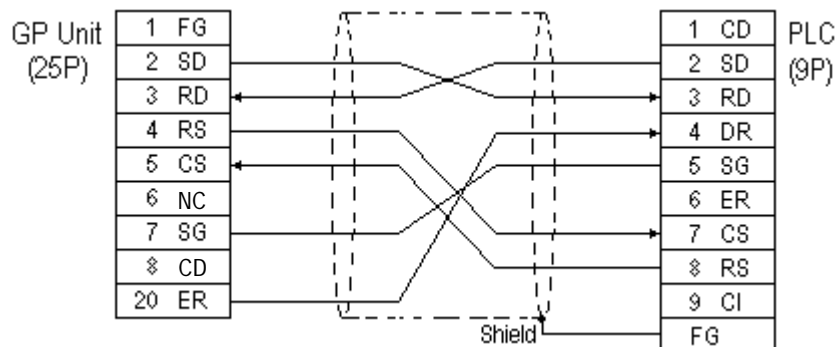

Cable Diagram 2 (RS-232)

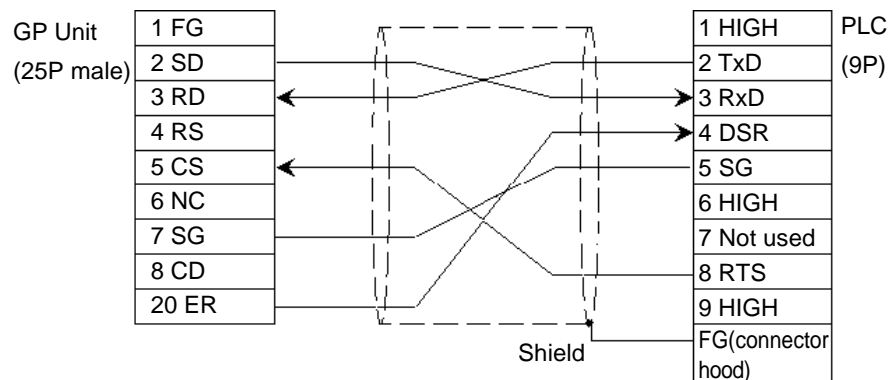





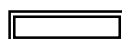

2.11.3 Supported Devices

The following describes the range of devices supported by the GP.

PROVISOR TC200 Series

 Setup System Area here.

Device	Bit Address	Word Address	Particulars
Input Relay 1	X000 ~ XF7F	XW00 ~ XWF7	*1*2
Input Relay 2	I000 ~ IF7F	IW00 ~ IWF7	*1*2
Output Relay 1	Y000 ~ YF7F	YW00 ~ YWF7	*1*2
Output Relay 2	O000 ~ OF7F	OW00 ~ OWF7	*1*2
Internal Relay	R000 ~ R77F	RW00 ~ RW77	*1*2
Extended Internal Relay 1	G000 ~ GF7F	GW00 ~ GWF7	*1*2
Extended Internal Relay 2	H000 ~ HF7F	HW00 ~ HWF7	*1*2
Extended Internal Relay 3	J000 ~ JF7F	JW00 ~ JWF7	*1*2
Extended Internal Relay 4	K000 ~ KF7F	KW00 ~ KWF7	*1*2
Special AUX Relay	A000 ~ A16F	AW00 ~ AW16	*1*2
Latch Relay	L000 ~ L07F	LW00 ~ LW07	*1*2
Shift Register	S000 ~ S07F	SW00 ~ SW07	*1*2
Edge Relay	E000 ~ E77F	EW00 ~ EW77	*1*2
Timer (contact)	T000 ~ T77F	TW00 ~ TW77	*1*2*4
Counter (contact)	C000 ~ C77F	CW00 ~ CW77	*1*2*4
Timer/Counter (current value)	—	P000 ~ P77F	 *3
Timer/Counter (setup value)	—	V000 ~ V77F	 *3
Generic Register 1	—	D000 ~ DF7F	 *3
Generic Register 2	—	B000 ~ BF7F	 *3
Generic Register 3	—	U000 ~ UF7F	 *3
Generic Register 4	—	M000 ~ MF7F	 *3
Generic Register 5	—	Q000 ~ QF7F	 *3

L/H

* 1 Word Address fields can differ between GP-PRO/PBIII for Windows and the corresponding PLC manual.

E.g. Input Relay

GP-PRO/PBIII	PLC Manual
XW00~XWF7	X00W~XF7W

Data cannot be written from the GP/GLC to the input relay (x,1). The calculation result in a ladder program takes priority for all the ladder program output section devices. Therefore, no data can be written from the GP/GLC.

E.g. Ladder Program

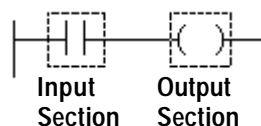

- *2 In GP-PRO/PB III for Windows, the word address' last digit is hexadecimal. You can enter any number between 0 and F as the last digit, however, since the PLC's word address' last digit is octal, you can only enter a number between 0 and 7 as the last digit.
- *3 In GP-PRO/PB III for Windows, the word address' second to last digit is hexadecimal and you can enter any number between 0 and F. However, since the PLC's word address' second to last digit and octal is you can only enter a number between 0 and 7 as the second to last digit.
- *4 The addresses of the timer/counter (contact) range from TW/CW00 to TW/CW77, however the internal memory area is not consecutive. This range is divided into two areas, e.g., TW/CW00 to TW/CW37 and TW/CW40 to TW/CW77.



Important

- **The number of consecutive words that can be used for the following GP-PRO/PB III and Pro-Server is limited:**

1) Number of monitored words using tag

- **Bit device (X, Y, I, O, R, G, H, J, K, A, L, S, E, T, C): No more than eight words can be specified.**
- **Word device (P, V, D, B, U, M, Q): No more than 127 words can be specified.**
- **Even if data is within the above word limit, no word can be specified outside of the octal range.**

The use of the a-tag allows you to specify words exceeding the limit.

E.g.) To monitor more than eight words (If the a-tag's Monitored Word Address is RW0 and you wish to monitor more than eight words, on the a-tag, set the Monitored Word Address to RW0 and set the Number of Monitored Words to 9 or more.

2) Number of addresses specified for copying stored data or initializing memory using D-Script's memory operation function

- **All devices: No more than 40 words can be specified.**

If this limit is exceeded, divide the words (into blocks that are within the limit) and then use the memory operation function.

3) LS Read area

- **When the entire system area is selected:
no more than 107 words can be specified.**
- **When the entire system area is deselected:
no more than 127 words can be specified.**
- * **The size that can be specified varies depending upon the selected number (20 words maximum) in the system area.**

- ***Even if data is within the above word limit of words, no word can be specified that is outside of the octal range.***

Words can only be used within the allowed range.

E.g.) If the entire system area is selected (20 words) and the first address of the system area is set to D060, no more than 12 words can be specified in the loading area.

4) Pro-Server

- ***All devices: No more than 40 words can be specified.***

If this limit is exceeded, divide the words (into blocks that are within the limit) and then write data.

- ***When data is batch loaded in batch from the PLC via the Pro-Server device monitor for the Pro-Server, the range can only be from the first device address up to the one just before the octal digit of a device address.***

5) Writing from SRAM to the PLC using the data filing function

- ***All devices: No more than 40 words can be specified.***

- ***Even if data is within the above word limit, no word can be specified that is outside of the octal range.***

E.g.) If the stored first address is set to D060, no more than 32 words can be specified as data.

If this limit is exceeded, divide the words (into blocks that are within the limit) and then write data.



- **The device type and range that can be used may vary depending upon your CPU. Check with the manual for your CPU before use.**

2.11.4 Environment Setup

The following lists Digital's recommended PLC and GP communication settings.

■ PROVISOR TC200 Series (using SIO module)

GP Setup		SIO Module Setup	
Baud Rate	9600 bps	Baud Rate	9600 bps
Data Length	8 bits	Data Bit	8 bits
Stop Bit	2 bits	Stop Bit	2 bits
Parity Bit	None	Parity Bit	None
Data Flow Control	ER Control	---	
Communication Format	RS-232C	---	
---		Select Function Switch	3 is On
Unit No.	0	PC Number	0

■ PROVISOR TC200 Series (using RS-232C Connector)

GP Setup		RS-232C Connector Setup	
Baud Rate	9600 bps	Baud Rate	9600 bps
Data Length	8 bits	Data Bit	8 bits
Stop Bit	2 bits	Stop Bit	2 bits
Parity Bit	None	Parity Bit	None
Data Flow Control	ER Control	---	
Communication Format	RS-232C	---	
Unit No.	64 (fixed)	---	