

# Device/PLC Connection Manuals

---



## About the Device/PLC Connection Manuals

Prior to reading these manuals and setting up your device, be sure to read the "Important: Prior to reading the Device/PLC Connection manual" information. Also, be sure to download the "Preface for Trademark Rights, List of Units Supported, How to Read Manuals and Documentation Conventions" PDF file. Furthermore, be sure to keep all manual-related data in a safe, easy-to-find location.

## 15.6 Toshiba Schneider Inverter Corporation



### 15.6.1 System Design

The following tables describe the methods for connecting Toshiba Schneider Inverter Corporation VF-S9/VF-nC1/VF-S11/VF-A7/VF-P7 Series inverters to the GP.



**If communication halts due to a signal cable break, GP/GLC fault etc., the inverter may not detect a stop command. When this occurs, be sure to stop communication via the inverter's external terminals.**

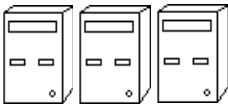

#### ■ VF-S9 Series

Inverter	Option Units	Wiring Diagram	Cables	Target Unit
				
VFS9□-□□□□□ □-□-□□□ <sup>*1</sup>		RS-232C <Diagram 1>	Made by Toshiba Schneider RS20035-0	GP/GLC/LT Series,ST401 ,Factory Gateway
	RS4001Z or RS4002Z <sup>*2</sup>	RS-422(4-wire) <Diagram 2>		GP/GLC/LT Series,ST400 ,Factory Gateway
		RS-422(4-wire 1:n Communication) <Diagram 3>		
	RS4001Z or RS4002Z	RS-422(2-wire) <Diagram 4>		
		RS-422 (2-wire, 1:n Communication) <Diagram 5>		

\*1 The data indicated by □ may vary, depending on the type of option selected.

\*2 The RS4001Z unit cannot be used for data communication at 19200bps. If communication at 19200bps is required, please use the RS4002Z.



## ■ VF-NC1 Series

Inverter	Option Units	Wiring Diagram	Cables	Target Unit
				
VFNC1□-□□□□□□ □-□-□□□ <sup>*1</sup>		RS-232C <Diagram 1>	Made by Toshiba Schneider RS20035-0	GP/GLC/LT Series,ST401 ,Factory Gateway
	RS4001Z or RS4002Z <sup>*2</sup>	RS-422(4-wire) <Diagram 2>		GP/GLC/LT Series,ST400 ,Factory Gateway
		RS-422(4-wire 1:n Communication) <Diagram 3>		
	RS4001Z or RS4002Z	RS-422(2-wire) <Diagram 4>		
RS-422 (2-wire, 1:n Communication) <Diagram 5>				

\*1 The data indicated by □ may vary, depending on the type of option selected.

\*2 The RS4001Z unit cannot be used for data communication at 19200bps. If communication at 19200bps is required, please use the RS4002Z.



## ■ VF-S11 Series

Inverter	Option Units	Wiring Diagram	Cables	Target Unit
				
VFS11□-□□□□□□ □□-□□-□□-□□ <sup>*1</sup>		RS-232C <Diagram 1>	Made by Toshiba Schneider RS20035-0	GP/GLC/LT Series,ST401 ,Factory Gateway
	RS4001Z or RS4002Z <sup>*2</sup>	RS-422(4-wire) <Diagram 2>		GP/GLC/LT Series,ST400 ,Factory Gateway
		RS-422(4-wire 1:n Communication) <Diagram 3>		
	RS4001Z or RS4002Z	RS-422(2-wire) <Diagram 4>		GP/GLC/LT Series,ST400 ,Factory Gateway
		RS-422 (2-wire, 1:n Communication) <Diagram 5>		
	Common Serial Communication Connector (RJ45) on RS4003Z	RS-232C <Diagram 1>	Made by Toshiba Schneider RS20035-1	GP/GLC/LT Series,ST401 ,Factory Gateway
	Common Serial Communication Connector (RJ45) on RS4003Z+ RS4001Z or RS4002Z	RS-422(4-wire) <Diagram 2>		GP/GLC/LT Series,/ST400 /Factory Gateway
		RS-422(4-wire 1:n Communication) <Diagram 3>		
		RS-422(2-wire) <Diagram 4>		
		RS-422 (2-wire, 1:n Communication) <Diagram 5>		
Control Circuit Terminal on RS4003Z	RS-422(4-wire) <Diagram 6>		GP/GLC/LT Series,/ST400 /Factory Gateway	
	RS-422(4-wire 1:n Communication) <Diagram 7>			
	RS-422(2-wire) <Diagram 8>			
	RS-422 (2-wire, 1:n Communication) <Diagram 9>			

\*1 The data indicated by □ may vary, depending on the type of option selected.

\*2 The RS4001Z unit cannot be used for data communication at 19200bps. If communication at 19200bps is required, please use the RS4002Z.

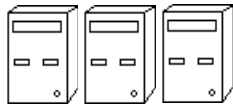
■ VF-A7 / VF-P7Series

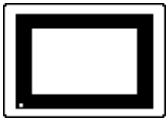
Inverter	Option Units	Wiring Diagram	Cables	Target Unit
				
VFA7-□□□□□□□□ -A□□ <sup>*1</sup> VFP7-□□□□□□□□ -A□□ <sup>*1</sup>		RS-232C <Diagram 1>	Made by Toshiba Schneider RS20035-0	GP/GLC/LT Series,ST401, Factory Gateway
	RS4001Z or RS4002Z <sup>*2</sup>	RS-422(4-wire) <Diagram 2>		GP/GLC/LT Series,ST400, Factory Gateway
		RS-422(4-wire 1:n Communication) <Diagram 3>		
	RS4001Z or RS4002Z	RS-422(2-wire) <Diagram 4>		
RS-422 (2-wire, 1:n Communication) <Diagram 5>				

\*1 The data indicated by □ may vary, depending on the type of option selected.

\*2 The RS4001Z unit cannot be used for data communication at 19200bps. If communication at 19200bps is required, please use the RS4002Z.

## ■ Connection Structure

### ◆ 1:1 Connection (RS-232C)

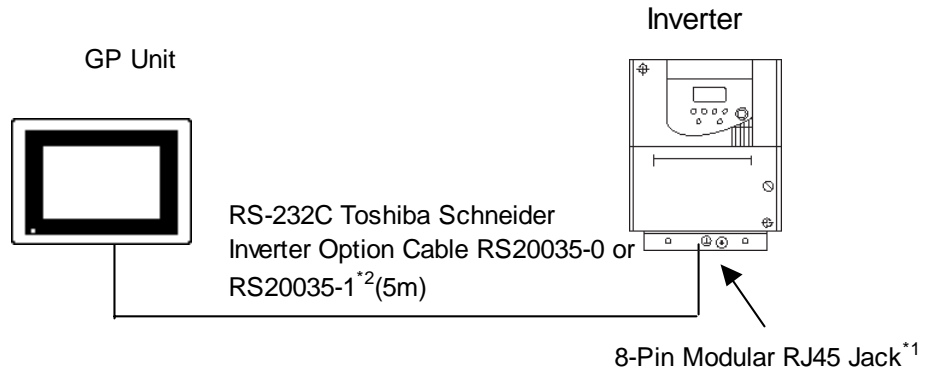

**Note:** Toshiba Schneider Inverter's option cable (RS20035) is required for this type of connection. (Cannot be created by user)

### ◆ 1:1 Connection (RS-422) when using the RS4001Z or the RS4002Z

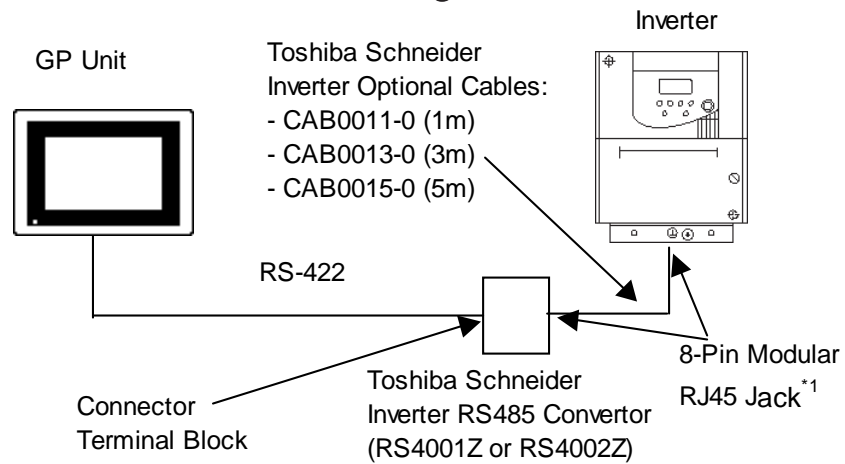

- Toshiba Schneider Inverter's optional cable and an RS485 convertor are required for this type of connection.
- The RS4001Z unit cannot be used for data communication at 19200bps. If communication at 19200bps is required, please use the RS4002Z.

\*1 Please use the 8-Pin Modular RJ45 Jack on the CPU or the RS4003Z.

\*2 When using the Link I/F on the CPU unit: RS20035-0

When using the Common Serial Communication Connector on the RS4003Z: RS20035-1

◆ **1:n Connection (RS-422) when using the RS4001Z or the RS4002Z Inverters (Max: 32 units)**

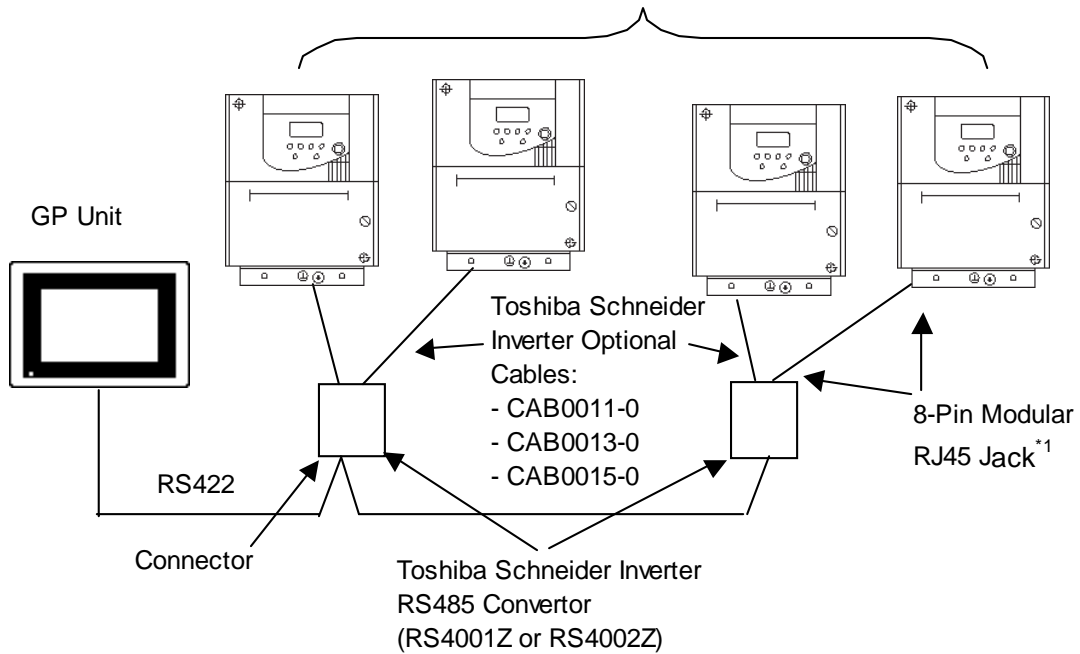

- Toshiba Schneider Inverter's optional cable and an RS485 convertor are required for this type of connection.
- The RS4001Z unit cannot be used for data communication at 19200bps. If communication at 19200bps is required, please use the RS4002Z.
- A maximum of 2 Toshiba Schneider Inverters can be connected to a single RS4001Z RS485 convertor, and a maximum of 8 Inverters can be connected to a single RS4002Z convertor.

◆ **1:1 Connection (RS-422) when using the Control Circuit Terminal on the RS4003Z**

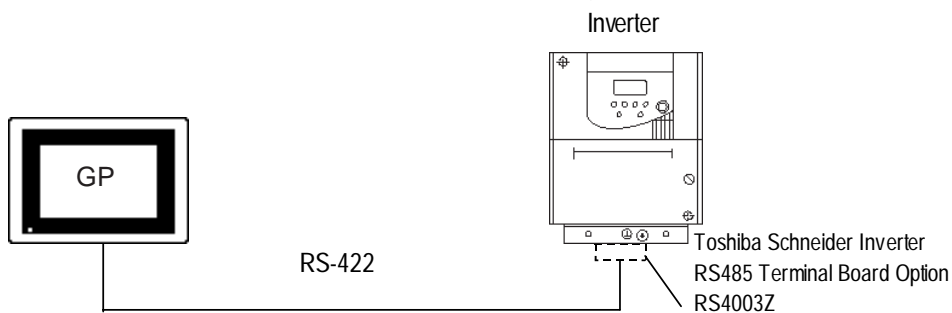

◆ **1:n Connection (RS-422) when using the Control Circuit Terminal on the RS4003Z**

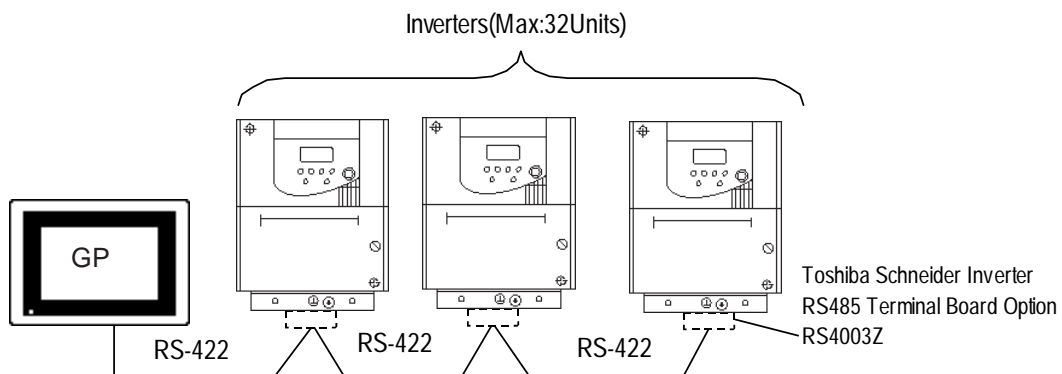

\*1 Please use the 8-Pin Modular RJ45 Jack on the CPU or the RS4003Z.

**15.6.2 Cable Diagrams**



- **Be sure the shield's ground wire is not connected to the Inverter or other unit's live earth wire.**
- **Be sure there is at least 20cm or more distance between the communication and main circuit lines.**
- **The following types of cables are recommended for RS-485 communication:**

Cable Name	Length	Manufacturer
KMPEV-SB 0.75mm <sup>2</sup> (Lay wire)	Max. 600m	Showa Densen Co.
KMPEV-SB 0.75mm <sup>2</sup> (Lay wire)	Max. 500m	
GECLS-9004 AWG24 0.2mm <sup>2</sup> (Simple wire)	Max. 300m	

**Cable Diagram 1 RS-232C**



**Note:** For RS-232C communication be sure to use Toshiba Schneider Inverter's RS20035 cable.

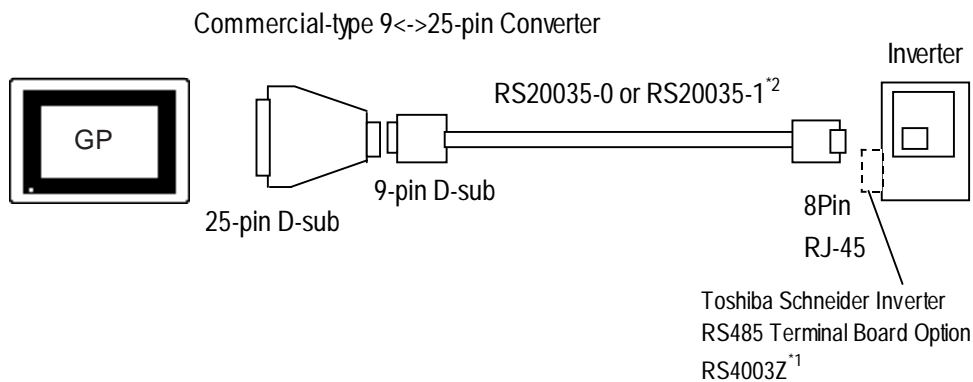

- **When using an ST Series Unit**

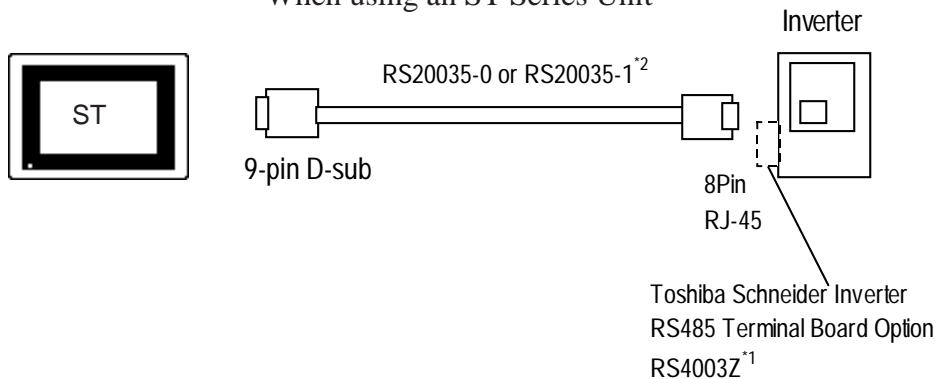

\*1 Not required when using the Link I/F on the CPU unit.

\*2 When using the Link I/F on the CPU unit: RS20035-0

When using the Common Serial Communication Connector on the RS4003Z: RS20035-1



**Cable Diagram 2 RS-422, 1:1**



- Note:**
- **Cable length: Max. 600m.**
  - **Turning the Converter unit (Inverter-side) dip switches (SW2-3, SW2-4) ON will insert termination resistance.**

<When using Pro-face's RS-422 connector terminal adapter GP070-CN10-0>

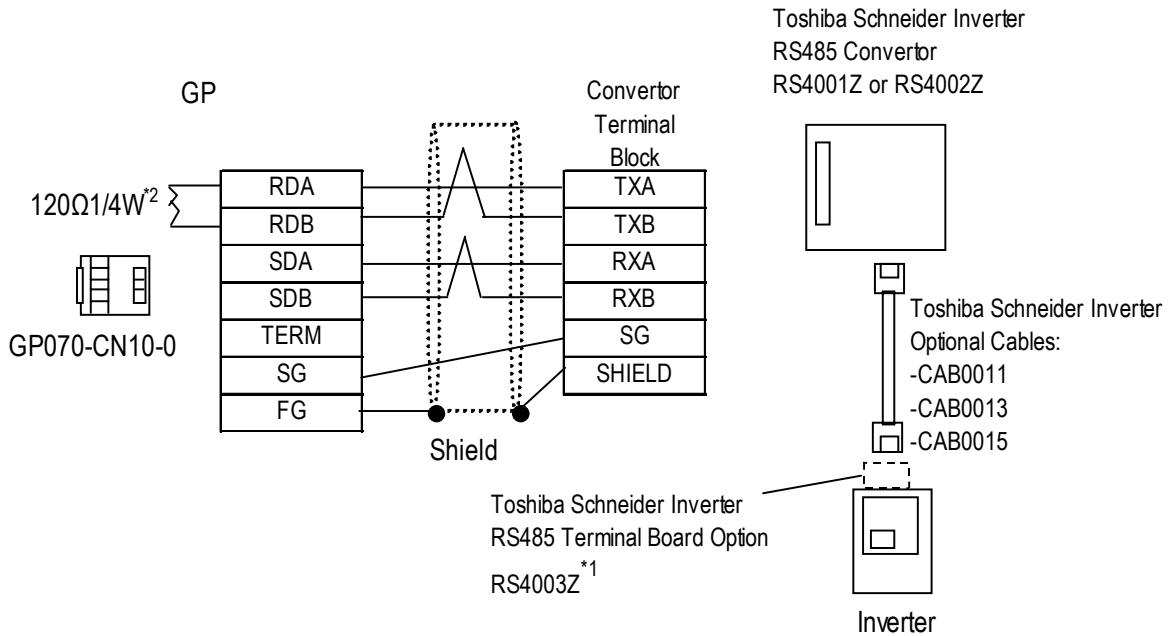

<When making your own cable>

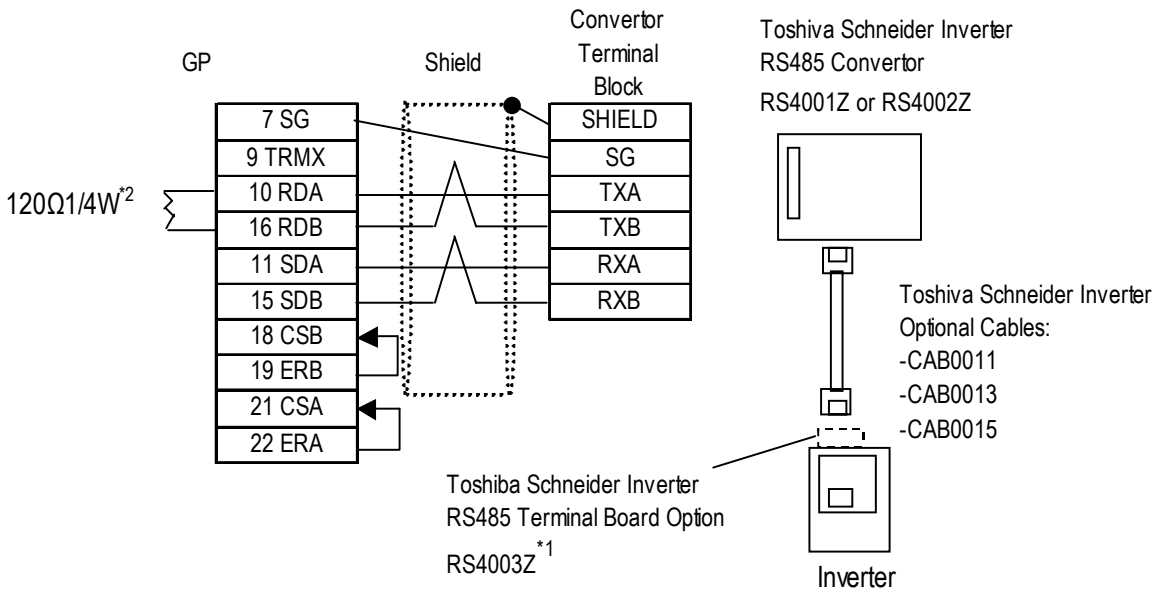

\*1 Not required when using the Link I/F on the CPU unit.

\*2 The termination resistance is 120Ω/2W when using the RS4003Z.

**Cable Diagram 3 RS-422, 1:n**



- **Cable length: Max. 600m.**
- **Turning the Converter unit's (RS4002Z: SW2-3, SW2-4; RS4001Z: SW3, SW4) dip switches ON will insert termination resistance. On the inverter side, the last conversion unit's dip switches should be turned ON.**

<When using Pro-face's RS-422 connector terminal adapter GP070-CN10-0>

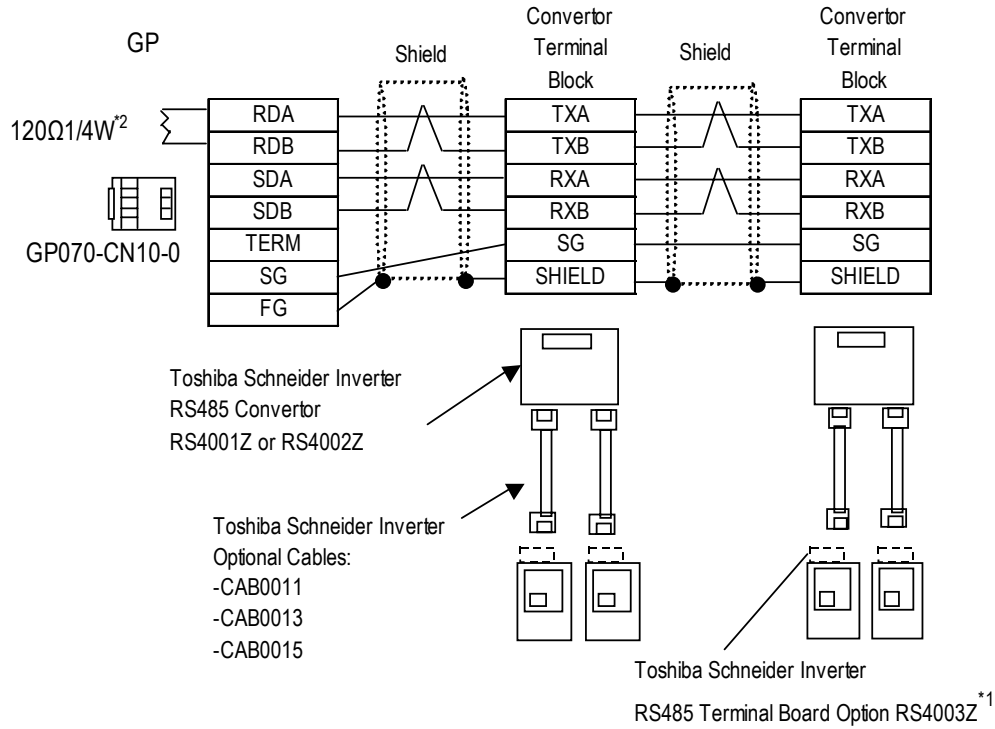

<When making your own cable>

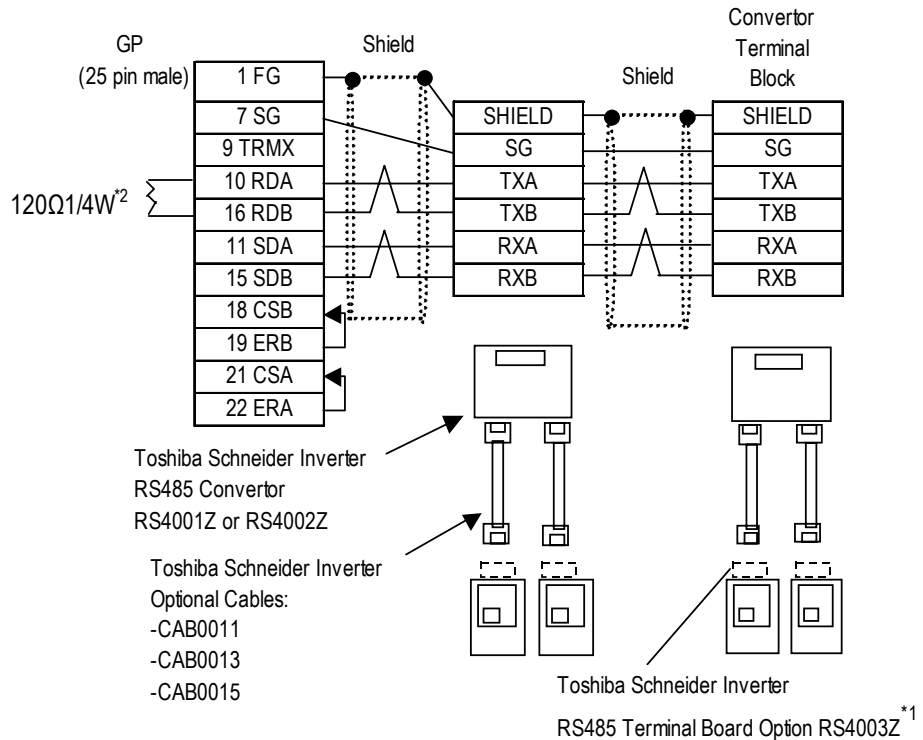

\*1 Not required when using the Link I/F on the CPU unit.

\*2 The termination resistance is 120WΩ1/2W when using the RS4003Z.

**Cable Diagram 4 RS-422, 1:1**



**Note:**

- **Cable length: Max. 600m.**
- **Turning the Converter unit's (RS4002Z: SW2-3, SW2-4; RS4001Z: SW3, SW4) dip switches ON will insert termination resistance.**
- **When using the RS4001Z unit for 2-wire data communication, be sure to short TXA and RXA, and TXB and RXB.**
- **When using the RS4001Z unit for 2-wire data communication, be sure to turn ON dip switches SW2-1 and SW2-2.**

<When using Pro-face's RS-422 connector terminal adapter GP070-CN10-0>

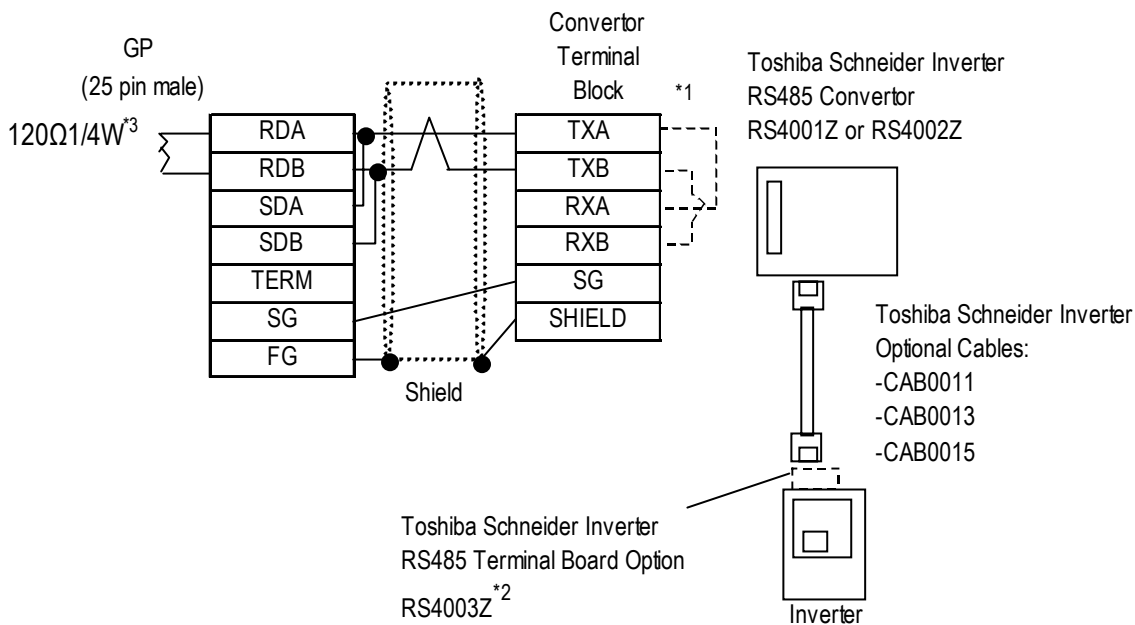

<When making your own cable>

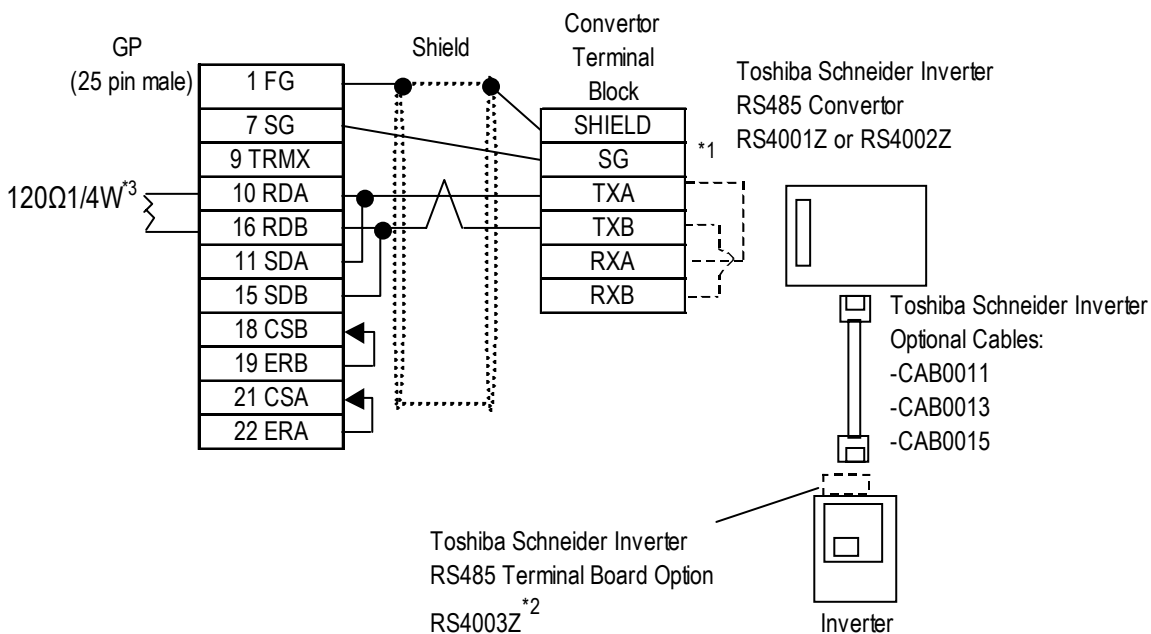

\*1 When using the RS4001Z, be sure to short the wires.

\*2 Not required when using the Link I/F on the CPU unit.

\*3 The termination resistance is 120Ω1/2W when using the RS4003Z.

**Cable Diagram 5 RS-422, 1:n**



- **Cable length: Max. 600m.**
- **Turning the Converter unit's (RS4002Z: SW2-3, SW2-4; RS4001Z: SW3, SW4) dip switches ON will insert termination resistance.**
- **When using the RS4001Z unit for 2-wire data communication, be sure to short TXA and RXA, and TXB and RXB.**
- **When using the RS4001Z unit for 2-wire data communication, be sure to turn ON dip switches SW2-1 and SW2-2.**

<When using Pro-face's RS-422 connector terminal adapter GP070-CN10-0>

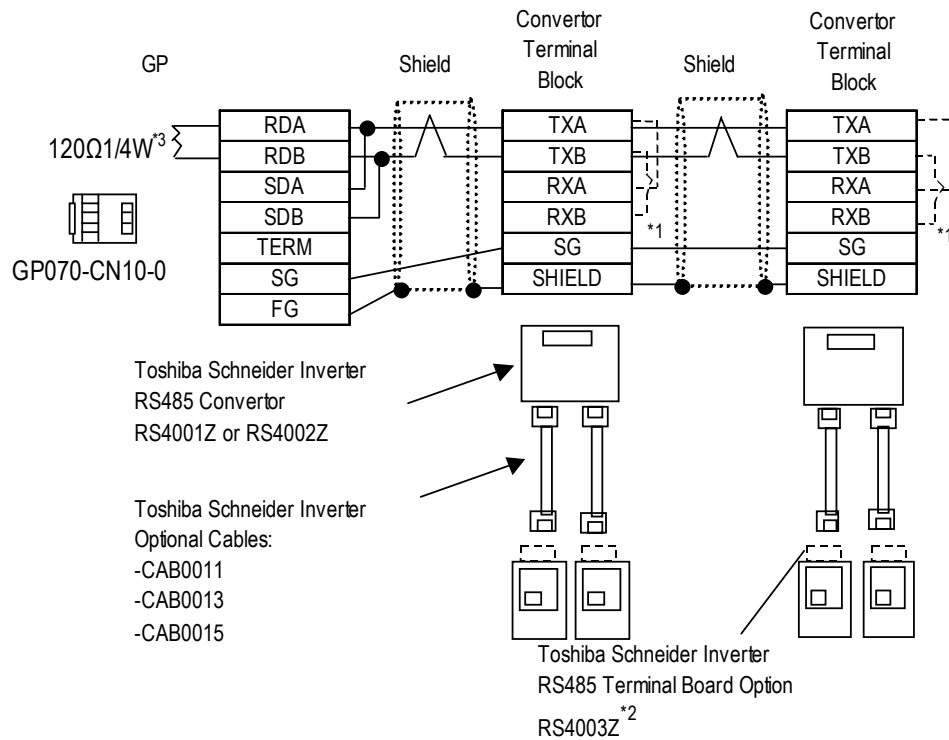

\*1 When using the RS4001Z, be sure to short the wires.

\*2 Not required when using the Link I/F on the CPU unit.

\*3 The termination resistance is 120Ω/2W when using the RS4003Z.

<When making your own cable>

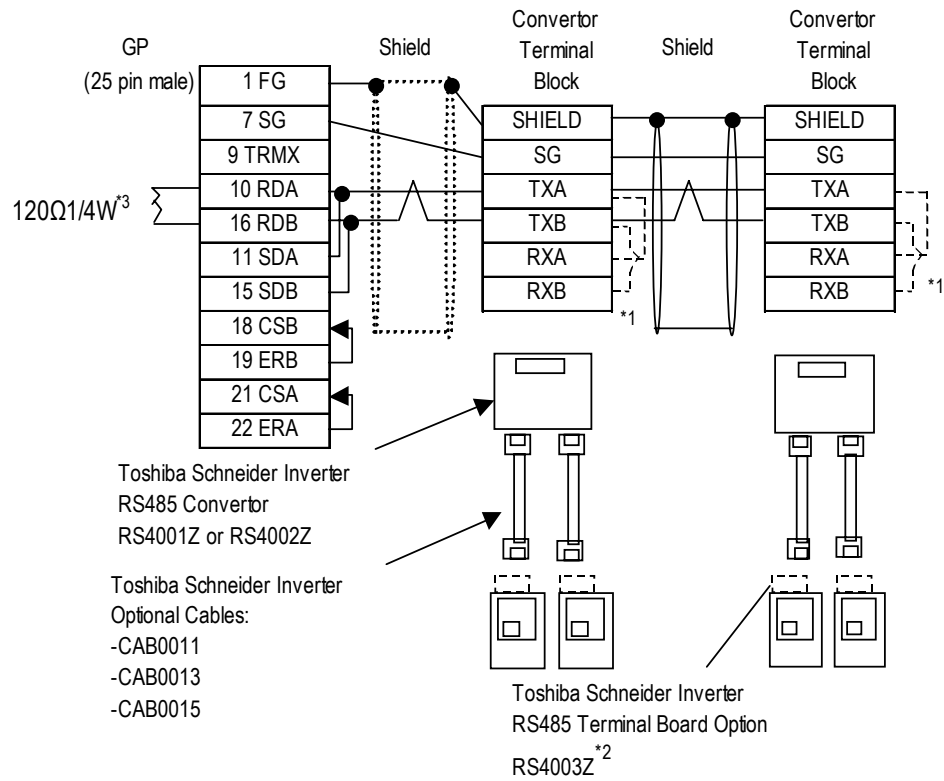

\*1 When using the RS4001Z, be sure to short the wires.

\*2 Not required when using the Link I/F on the CPU unit.

\*3 The termination resistance is 120Ω1/2W when using the RS4003Z.

**Cable Diagram 6 RS-422, 1:n**



**Note:** Turning the RS4003Z's termination resistance setting switches (SW2-R, SW2-T) ON will insert termination resistance.

<When using Pro-face's RS-422 connector terminal adapter GP070-CN10-0>

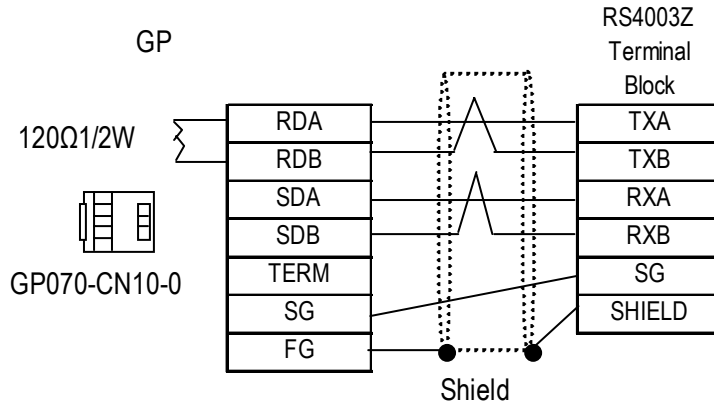

<When making your own cable>

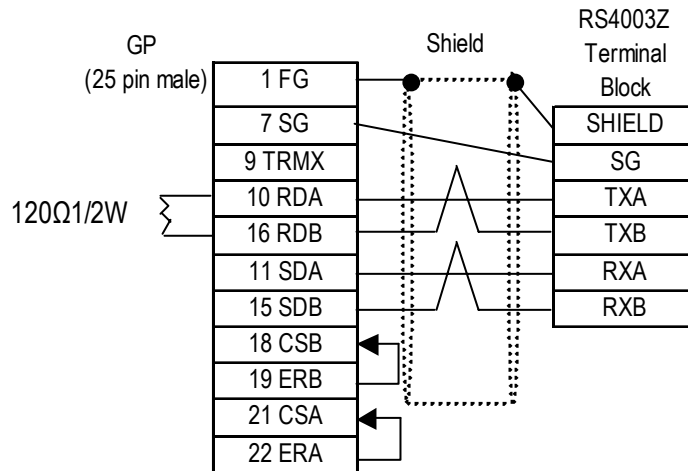

### Cable Diagram 7 RS-422, 1:n



**Note:** Turning the RS4003Z's termination resistance setting switches (SW2-R, SW2-T) ON will insert termination resistance. For the inverter's side, turn ON the termination resistance dip switch of the last terminal's converter.

<When using Pro-face's RS-422 connector terminal adapter GP070-CN10-0>

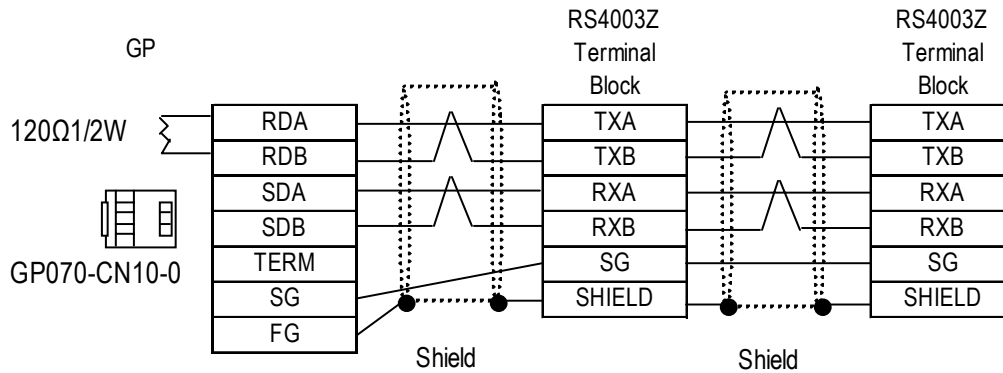

<When making your own cable>

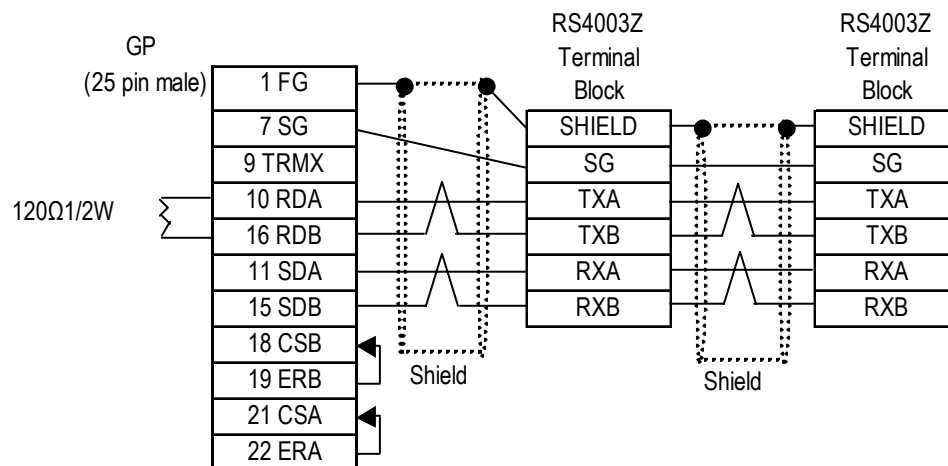

### Cable Diagram8 RS-422, 1:n



**Note:** Turning ON the termination resistance setting dip switch (SW2-T) on the inverter's side will insert termination resistance.

<When using Pro-face's RS-422 connector terminal adapter GP070-CN10-0>

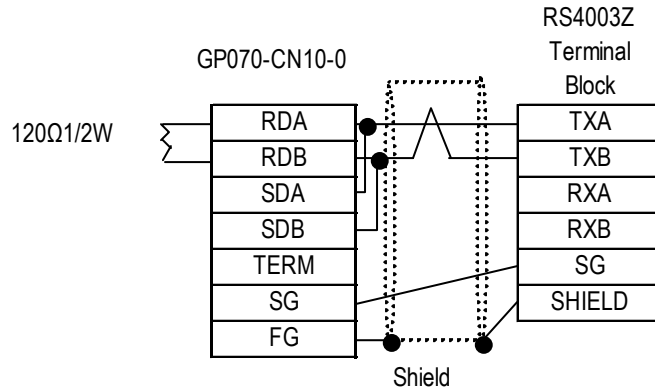

<When making your own cable>

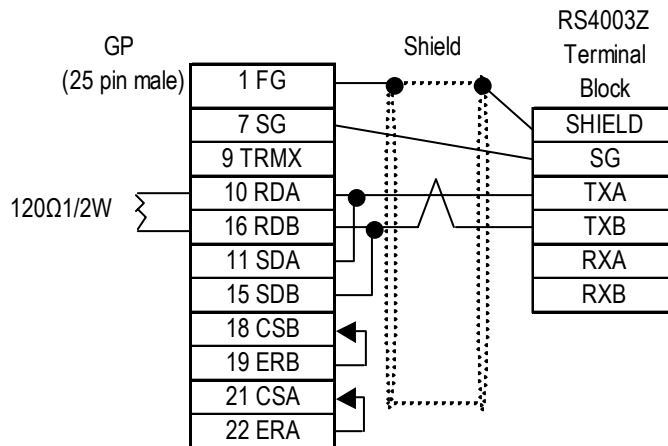



### Cable Diagram 9 RS-422, 1:n



**Note:** Turning ON the termination resistance setting dip switch (SW2-T) on the inverter's side will insert termination resistance.

<When using Pro-face's RS-422 connector terminal adapter GP070-CN10-0>

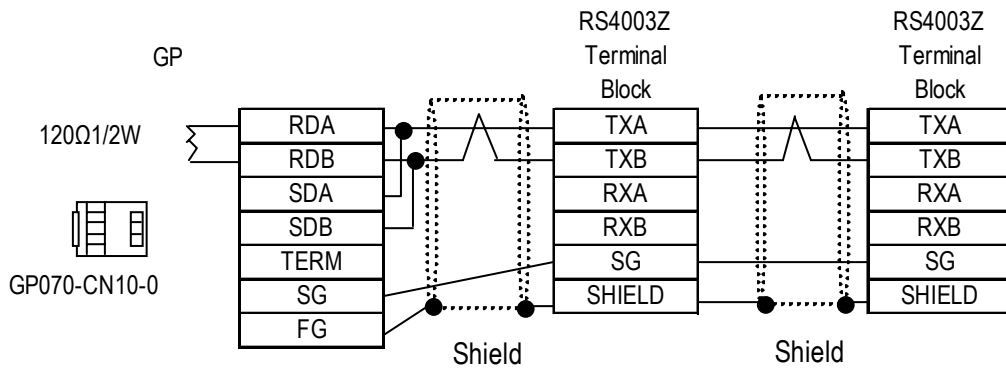

<When making your own cable>

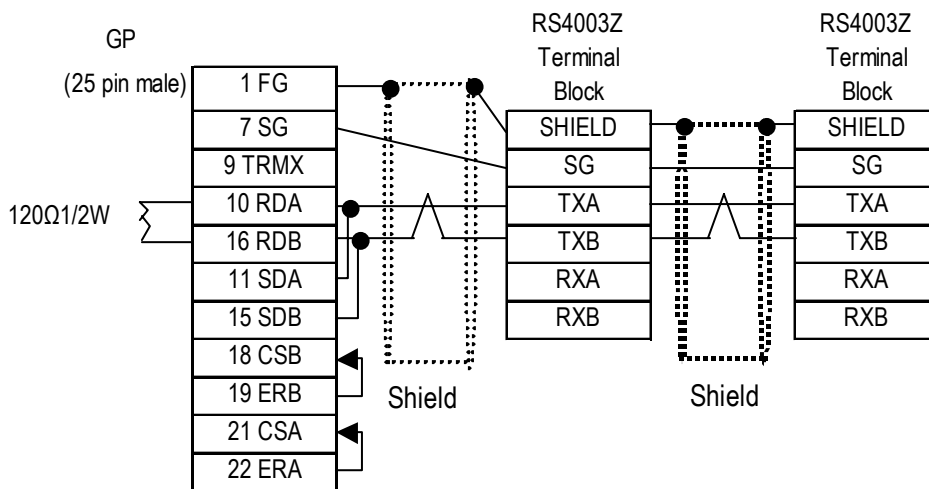

























With an ST Series unit, the cable must be created by the user. Also, as shown below, the GP and ST pin numbers are different. Please use this table when creating your cable.

ST Pin No.	ST Pin Name	GP Series Pin No.
1	RDA	10
2	RDB	16
3	SDA	11
4	ERA	22
5	SG	7
6	CSB	18
7	SDB	15
8	CSA	21
9	ERB	19
Connector Shell	FG	1

### 15.6.3 Supported Devices

#### ■ VF-A7/ VF-P7 Series























Device	Bit Address	Word Address	Description	
Standard Parameters	----	0000 to 0024		H/L
	----	W0000 to W0024		
Extended Parameters	----	0100 to 0199		
	----	W0100 to W0199		
	----	0200 to 0294		
	----	W0200 to W0294		
	----	0300 to 0398		
	----	W0300 to W0398		
	----	0400 to 0491		
	----	W0400 to W0491		
	----	0500 to 0599		
	----	W0500 to W0599		
	----	0600 to 0697		
	----	W0600 to W0697		
	----	0700 to 0730		
	----	W0700 to W0730		
	----	0800 to 0899		
	----	W0800 to W0899		
Instruction	----	FA00 to FA51		
Monitor	----	FB05 to FB58	 <sup>1</sup>	
	----	FC90 to FC91	 <sup>1</sup>	
	----	FD00	 <sup>1</sup>	
	----	FE00 to FE71	 <sup>1</sup>	

\*1 Read-only device.



**Note:** When data is designated as being written to a W\*\*\*\* address, data is written to both RAM and EEPROM memory. When this type of address is not used, data is written to only RAM. Since EEPROM memory has a limited (finite) number of writes (10,000 times) that can be performed, if data backup (retention) is not required, write data only to RAM memory.

## ■ VF-nC1 Series























Device	Bit Address	Word Address	Description	
Standard Parameters	----	0003 to 0024		H/L
	----	W0003 to W0024		
Extended Parameters	----	0100 to 0173		
	----	W0100 to W0173		
	----	0201 to 0294		
	----	W0201 to W0294		
	----	0300 to 0363		
	----	W0300 to W0363		
	----	0400 to 0419		
	----	W0400 to W0419		
	----	0500 to 0505		
	----	W0500 to W0505		
	----	0600 to 0633		
	----	W0600 to W0633		
	----	0700 to 0710		
	----	W0700 to W0710		
	----	0800 to 0880		
	----	W0800 to W0880		
Instruction	----	FA00 to FA03		
Monitor	----	FC90 to FC91		
	----	FD00 to FD07		<sup>*1</sup>
	----	FE00 to FE73		<sup>*1</sup>

*\*1 Read-only device.*



**Note:** When data is designated as being written to a W\*\*\*\* address, data is written to both RAM and EEPROM memory. When this type of address is not used, data is written to only RAM. Since EEPROM memory has a limited (finite) number of writes (10,000 times) that can be performed, if data backup (retention) is not required, write data only to RAM memory.

■ VF-S9 Series

Device	Bit Address	Word Address	Description
Standard Parameters	-----	0000 to 0041	
	-----	W0000 to W0041	
Extended Parameters	-----	0100 to 0173	
	-----	W0100 to W0173	
	-----	0200 to 0294	
	-----	W0200 to W0294	
	-----	0300 to 0363	
	-----	W0300 to W0363	
	-----	0400 to 0408	
	-----	W0400 to W0408	
	-----	0500 to 0505	
	-----	W0500 to W0505	
	-----	0600 to 0692	
	-----	W0600 to W0692	
	-----	0700 to 0710	
	-----	W0700 to W0710	
	-----	0800 to 0880	
	-----	W0800 to W0880	
Instruction	-----	FA00 to FA02	
Monitor	-----	FC00 to FC91	 <sup>1</sup>
	-----	FD00	 <sup>1</sup>
	-----	FE00 to FE71	 <sup>1</sup>

H/L

\*1 Read-only device.



**Note:** When data is designated as being written to a W\*\*\*\* address, data is written to both RAM and EEPROM memory. When this type of address is not used, data is written to only RAM. Since EEPROM memory has a limited (finite) number of writes (10,000 times) that can be performed, if data backup (retention) is not required, write data only to RAM memory.

■ VF-S11 Series

Device	Bit Address	Word Address	Description
Standard Parameters	-----	0000 to 0024	[Bit] [5]
	-----	W0000 to W0024	[Bit] [5]
Extended Parameters	-----	0100 to 0185	[Bit] [5]
	-----	W0100 to W0185	[Bit] [5]
	-----	0200 to 0294	[Bit] [5]
	-----	W0200 to W0294	[Bit] [5]
	-----	0300 to 0366	[Bit] [5]
	-----	W0300 to W0366	[Bit] [5]
	-----	0400 to 0494	[Bit] [5]
	-----	W0400 to W0494	[Bit] [5]
	-----	0500 to 0513	[Bit] [5]
	-----	W0500 to W0513	[Bit] [5]
	-----	0600 to 0692	[Bit] [5]
	-----	W0600 to W0692	[Bit] [5]
	-----	0700 to 0736	[Bit] [5]
	-----	W0700 to W0736	[Bit] [5]
	-----	0800 to 0894	[Bit] [5]
	-----	W0800 to W0894	[Bit] [5]
	-----	0910 to 0911	[Bit] [5]
	-----	W0910 to W0911	[Bit] [5]
Instruction	-----	FA00 to FA02	[Bit] [5]
Monitor	-----	FC00 to FC91	[Bit] [5] <sup>*1</sup>
	-----	FD00	[Bit] [5] <sup>*1</sup>
	-----	FE00 to FE71	[Bit] [5] <sup>*1</sup>

H/L

*\*1 Read-only device.*



**When data is designated as being written to a W\*\*\*\* address, data is written to both RAM and EEPROM memory. When this type of address is not used, data is written to only RAM. Since EEPROM memory has a limited (finite) number of writes (10,000 times) that can be performed, if data backup (retention) is not required, write data only to RAM memory.**



**Note:** Inverter parameters are allocated to the device and address, as shown below. The command number or the parameter's function code is displayed in the device. For details,

▼ **Reference** ■ Inverter Commands

▼ **Reference** ■ Parameter Function Codes

▼ **Reference** ■ Parameter Numbers

The screenshot shows the 'N Tag Setting' window with tabs for 'General Info.', 'Data Format', 'Size/Style', 'Alarm Settings', and 'Arithmetic Operation'. The 'Absolute' radio button is selected. The 'Word Address' field contains '01/00\_00'. A 'Word Address' dialog box is open, showing '00\_' in the unit field, '00' in the command field, and '01' in the parameter field. Arrows point from these fields to explanatory text on the right.

Enter the unit no. of the inverter you wish to designate

Displays the parameter number

01 / 00\_00

Displays the command number or the parameter function code

Parameter Number

Command Number or Parameter Function Code

Inverter Unit No.

## GP/GLC System Data Area (LS0 to LS19)



**The system area (LS0 to LS19) of the GP/GLC cannot be allocated to the data area available on the inverter. Even if the system area is set using GP-PRO/PBIII or the GP/GLC offline mode, this allocation cannot be made. For the following and later system versions, system area data cannot be sent to the inverter even though the system data area has been allocated (selected) to the data area available on the inverter.**

GP/GLC Model	GP77R Series	GP377 Series	GLC300 Series	GLC2000 Series	GP2000 Series	LT
System Version	Ver. 2.60	Ver. 2.60	Ver. 2.60	Ver. 2.45	Ver. 3.10	Ver. 2.69b

### ■ Inverter Commands

Inverter parameters are allocated the following communication codes. When setting up Tags, the left-most two digits are for the device name, and the right-most two digits are for the device address. For detailed information, refer to your inverter manual's Parameter List.

GP unit's designated Device Address

Communication Number	Feature
0000	Inverter-based speed increase/decrease
0001	Inverter-based control
0002	Select type of operation
0003	Select speed command
0004	:
0005	:



## 4. Environment Setup

The following table shows Digital's recommended Toshiba Schneider Inverter Corporation's communication settings and their corresponding settings on the GP.

GP Settings		Inverter Settings	
Baud Rate	9600 bps	Baud Rate (F800) <sup>*1</sup>	9600 bps
Data Length	8 bits (fixed)	-----	-----
Stop Bit	1 bits (fixed)	-----	-----
Parity Bit	Even	Parity (F801) <sup>*1</sup>	Even
Control Method	ER	-----	-----
Communication Format (4-wire)	4-wire	RS485 <sup>*2*4</sup>	4-wire
Communication Format (2-wire)	2-wire	RS485 <sup>*2*3*4</sup>	2-wire
Communication Format (RS232C)	RS-232C	-----	-----
Station No.	0	Inverter No. (F802) <sup>*5</sup>	0

*\*1 Inverter settings should be entered via the Function Mode's parameters.*

*For details, refer to your inverter's manual.*

*Use the Toshiba Schneider Inverter's RS485 Convertor unit's dip switches to enter settings for that unit. Be sure that the settings are the same as those used on the inverter unit.*

*\*2 Only the Toshiba Schneider Inverter RS485 Convertor RS4002Z unit has settings. This is performed via the unit's dip switches (4-wire: OFF for both SW2-1 and SW2-2, 2-wire: ON for both SW2-1 and SW2-2).*

*\*3 When using the Toshiba Schneider Inverter RS4001Z unit for RS-485 2-wire data communication, be sure to short TXA and RXA, and TXB and RXB before using the unit.*

*\*4 When using the Toshiba Schneider Inverter RS485 Terminal Board Option RS4003Z, the setting is performed via the unit's wire type change switches (4-wire: 4, 2-wire: 2).*

*\*5 When connecting the Inverter to a GP unit, use numbers 0 to 31.*