

# Device/PLC Connection Manuals

---



## About the Device/PLC Connection Manuals

Prior to reading these manuals and setting up your device, be sure to read the "Important: Prior to reading the Device/PLC Connection manual" information. Also, be sure to download the "Preface for Trademark Rights, List of Units Supported, How to Read Manuals and Documentation Conventions" PDF file. Furthermore, be sure to keep all manual-related data in a safe, easy-to-find location.



## 2.17 Rockwell (Allen-Bradley)

### 2.17.1 System Structure



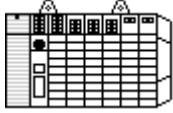

The following describes the system structure for connecting the GP to Rockwell (Allen-Bradley) PLCs.

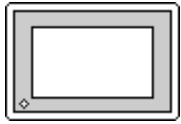
**Reference** *The Cable Diagrams mentioned in the following tables are listed in the section titled "2.17.2 Cable Diagrams".*

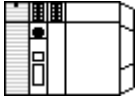

#### ■ SLC 500 Series (using CPU unit Link I/F)

CPU	Cable Diagram	GP
		
SLC-5/03 SLC-5/04	RS-232C (Cable Diagram 1)	GP Series ST401

#### ■ PLC-5 Series (using Link I/F)

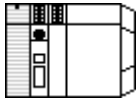

CPU	Link I/F	Cable Diagram	Target Machine
	 DATA HIGHWAY PLUS		
All PLC-5 processors which can connect one of the link unit shown on the right.	1785-KE 1785-KE/C	RS-232C (Cable Diagram 2)	GP/GLC Series ST401
	1770-KF2	RS-232C (Cable Diagram 3)	GP/GLC Series ST401
		RS-422 (Cable Diagram 4)	GP/GLC Series ST400

■ **PLC-5 Series (CPU Direct Connection)**

CPU *1	Cables Diagram	Target Machine
		
PLC-5/11 PLC-5/20 PLC-5/30 PLC-5/40 PLC-5/40L PLC-5/60 PLC-5/60L	RS-232C (Cable Diagram 3)	GP/GLC Series ST401
	RS-422 (Cable Diagram 5)	GP/GLC Series ST400

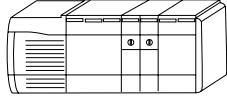

\*1 Connect to Channel 0 (CH0).

■ **ControlLogix 5000 Series (using CPU unit Link I/F)**



CPU	Cable Diagram	GP/GLC
		
1756-L1 1756-L1M1 1756-L1M2 1756-L1M3 1756-L55M13 1756-L55M14 1756-L55M16	RS-232C <Cable Diagram 6>	GP/GLC Series *1 ST401

\*1 This PLC can be connected only to GP2000 Series, GLC2000 Series, and GP377 Series units.



■ **MicroLogix 1000 Series (CPU Direct Connection)**

CPU	Link	Cable Diagram	Target Machine
			
1761-L16AWA 1761-L32AWA 1761-L20AWA-5A 1761-L10BWA 1761-L16BWA 1761-L20BWA-5A 1761-L32BWA 1761-L10BWB 1761-L16BWB 1761-L20BWB-5A 1761-L32BWB 1761-L16BBB 1761-L32BBB 1761-L32AAA	RS-232C port on CPU unit	RS-232C <Cable Diagram 7>	GP/GLC Series  ST401



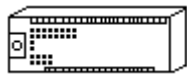

■ **MicroLogix 1200 Series (CPU Direct Connection)**

CPU	Link	Cable Diagram	Target Machine
			
1762-L24AWA 1762-L24BWA 1762-L24BXB 1762-L40AWA 1762-L40B WA 1762-L40BXB	RS-232C port on CPU unit	RS-232C <Cable Diagram 7>	GP/GLC Series  ST401





■ **MicroLogix 1500 Series (CPU Direct Connection)**

CPU	Link	Cable Diagram	Target Machine
			
1764-LSP	RS-232C port on Base unit	RS-232C <Cable Diagram 7>	GP/GLC Series ST401



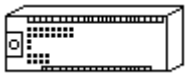

■ **MicroLogix 1000 Series** (using Advanced Interface Converter)

CPU	Link	Cable Diagram	Target Machine
			
1761-L16AWA 1761-L32AWA 1761-L20AWA-5A 1761-L10BWA 1761-L16BWA 1761-L20BWA-5A 1761-L32BWA 1761-L10BWB 1761-L16BWB 1761-L20BWB-5A 1761-L32BWB 1761-L16BBB 1761-L32BBB 1761-L32AAA	Advanced Interface Converter (1761-NET-AIC)	RS-232C <Cable Diagram 8>	GP/GLC Series  ST401



■ **MicroLogix 1200 Series** (using Advanced Interface Converter)

CPU	Link	Cable Diagram	Target Machine
			
1762-L24AWA 1762-L24BWA 1762-L24BXB 1762-L40AWA 1762-L40BWA 1762-L40BXB	Advanced Interface Converter (1761-NET-AIC)	RS-232C <Cable Diagram 8>	GP/GLC Series  ST401

■ **MicroLogix 1500 Series** (using Advanced Interface Converter)

CPU	Link	Cable Diagram	Target Machine
			
1764-LSP	Advanced Interface Converter (1761-NET-AIC)	RS-232C <Cable Diagram 8>	GP/GLC Series  ST401

■ **CompactLogix 5000 Series** (using CPU Link I\F unit)

CPU	Link	Cable Diagram	Target Machine
			
1762-L24AWA 1762-L24BWA 1762-L24BXB 1762-L40AWA 1762-L40BWA 1762-L40BXB	Advanced Interface Converter (1761-NET-AIC)	RS-232C <Cable Diagram 8>	GP/GLC Series  ST401

*\*1 Connection is possible with GP377 Series, GP77R Series, GP2000 Series and GLC2000 Series units.*

**2.17.2 Cable Diagrams**

The cable diagrams illustrated below and the cable diagrams recommended by Rockwell (Allen-Bradley) may differ; however, using these cables for your PLC operations will not cause any problems.



Ground your PLC's FG terminal according to your country's applicable standard. For details, refer to the corresponding PLC manual.



- **Connect the FG line of the Shield cable to either the GP or PLC, depending on your environment. When using a connector hood and grounding the FG line, be sure to use an electrical conductor.**
- **For the RS-232C connection, use a cable length less than 15m.**
- **If a communications cable is used, it must be connected to the SG (signal ground).**
- **For the RS-422 connection, refer to Rockwell's PLC manual for the cable length.**

Cable Diagram 1

**GP/GLC Series Units**

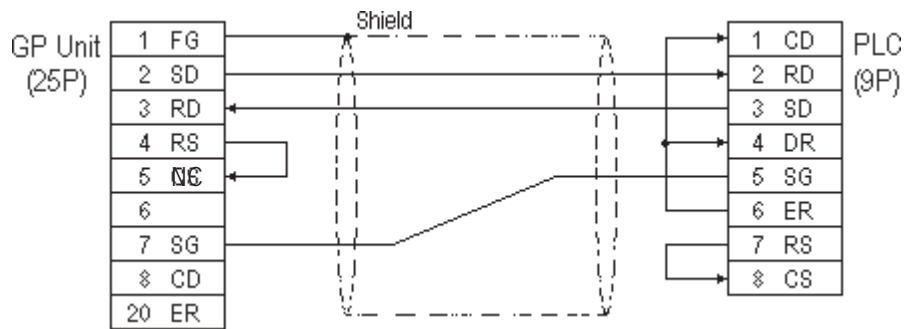

**ST401 Unit**

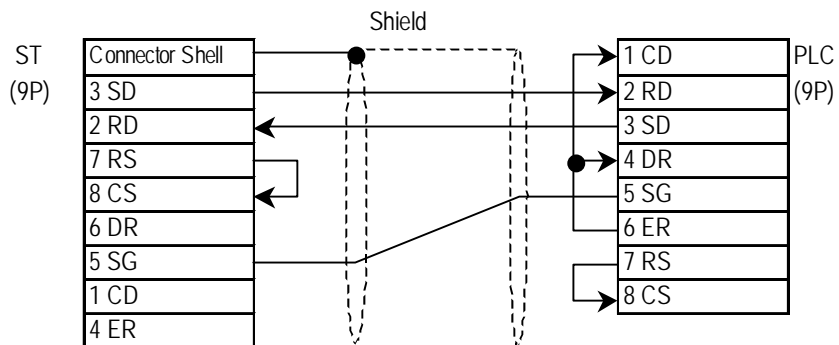

## Cable Diagram 2

### GP/GLC Series Units

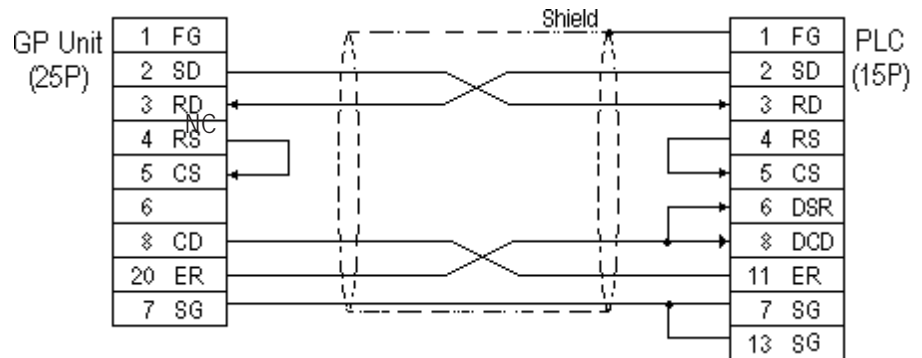

### ST401 Unit

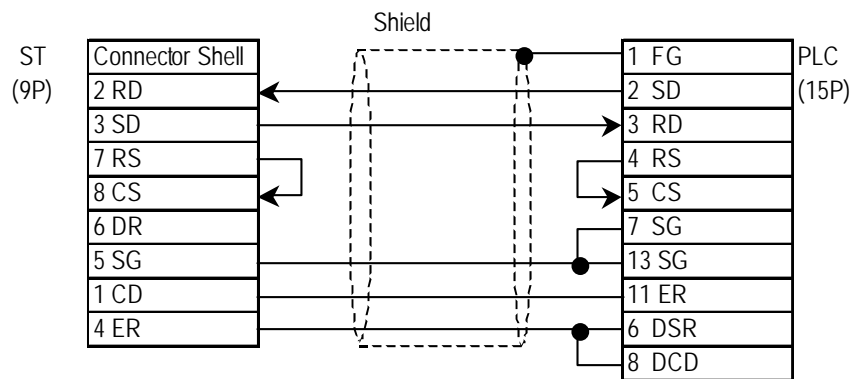



### Cable Diagram 3

#### GP/GLC Series Units

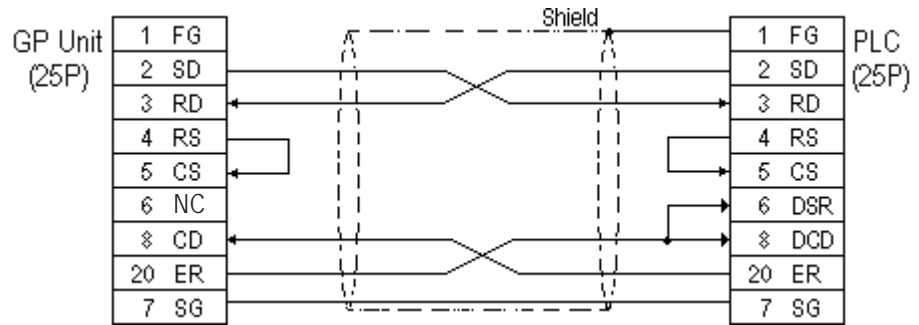

#### ST401 Unit

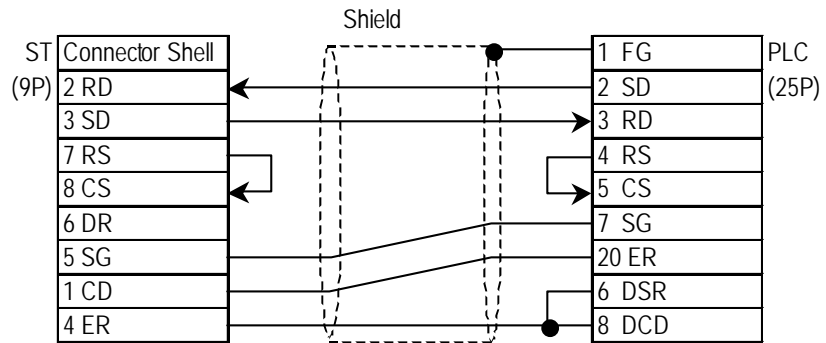

### Cable Diagram 4

#### GP/GLC Series Units

- When using Digital's RS-422 connector terminal adapter, GP070-CN10-0

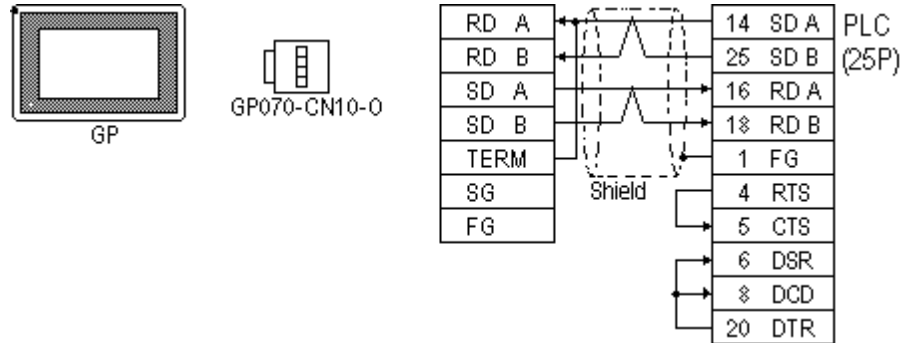

- When using Digital's RS-422 Cable, GP230-IS11-0

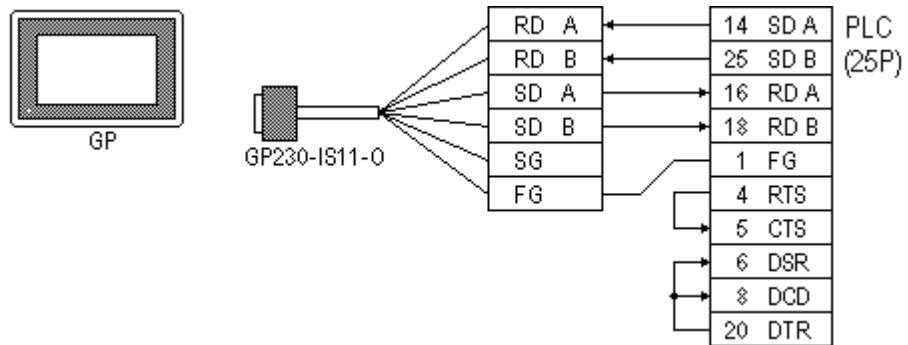

- When making your own cable connections

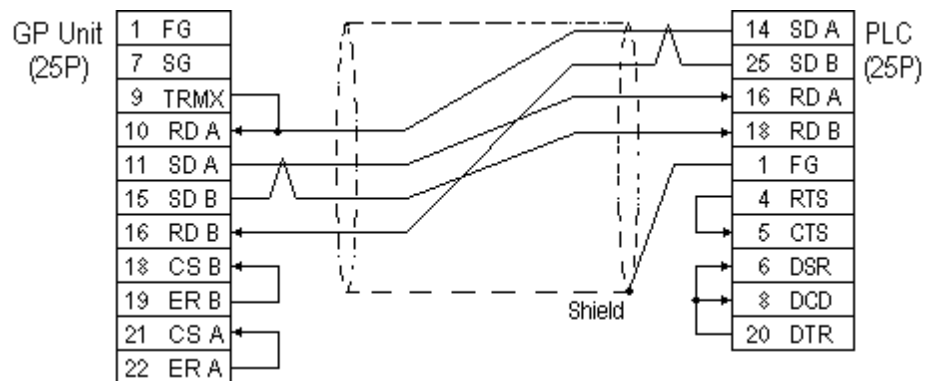

**Note:** When connecting the #9 and #10 pins in the GP Serial I/E, a termination resistance of 100Ω is added between RDA and RDB.

### ST400 Unit

- When using Digital's RS-422 cable CA3-CBL422/5M-01

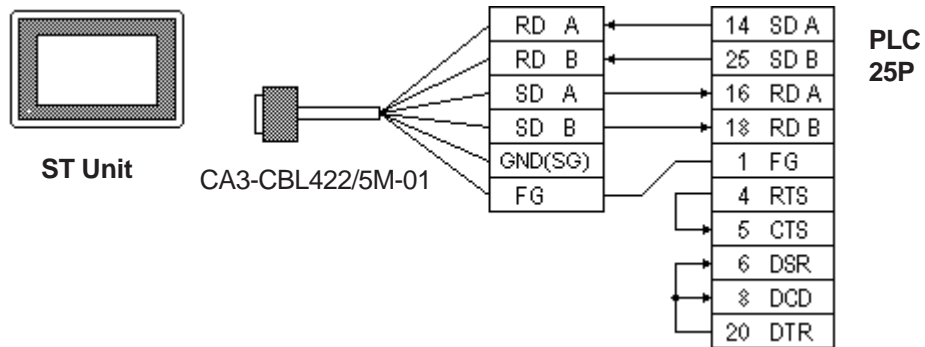

**Note:** Be sure to connect the FG line to the FG terminal. For information about FG connections, refer to page 1-5 note \*1, in the "Connecting a Device/PLC to the ST unit."

- When making your own cable connections

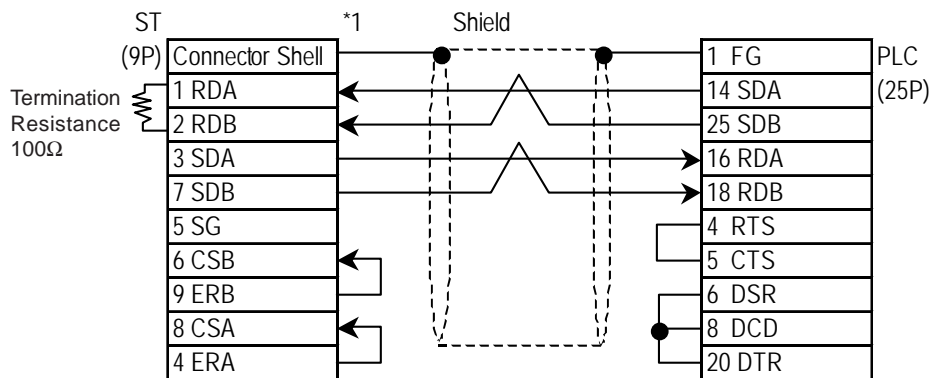

\*1 Be sure to connect the shield to the Connector Shell. For information about FG connections, refer to page 1-2 "RS422 I/F (ST400)" section's Note, in the "Connecting a Device/PLC to the ST unit."

### Cable Diagram 5

#### GP/GLC Series Units

- When using Digital's RS-422 connector terminal adapter, GP070-CN10-0

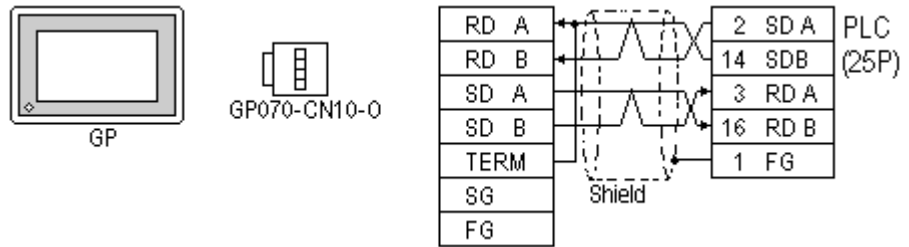

- When using Digital's RS-422 Cable, GP230-IS11-0

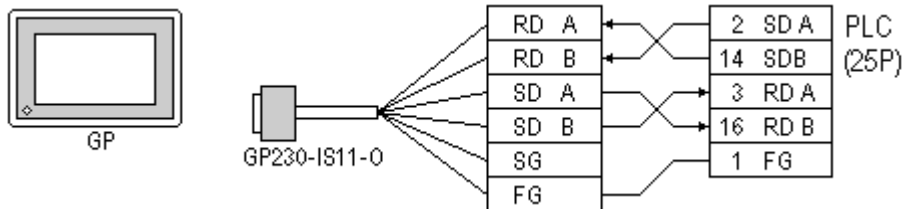

- When making your own cable connections

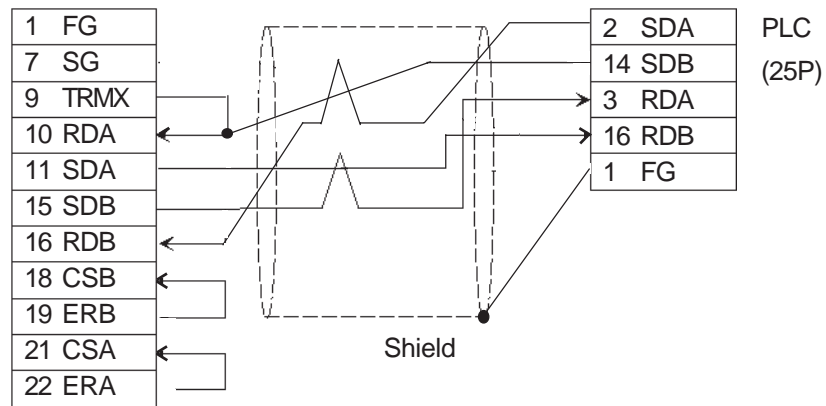

**When connecting the #9 and #10 pins in the GP Serial I/F, a termination resistance of 100Ω is added between RDA and RDB.**

### ST400 Unit

- When using Digital's RS-422 cable CA3-CBL422/5M-01

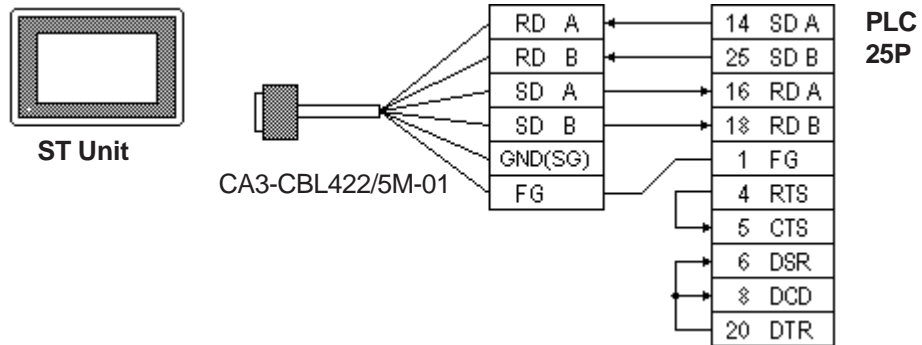

**Note:** Be sure to connect the FG line to the FG terminal. For information about FG connections, refer to page 1-5 note \*1, in the "Connecting a Device/PLC to the ST unit."

- When making your own cable connections

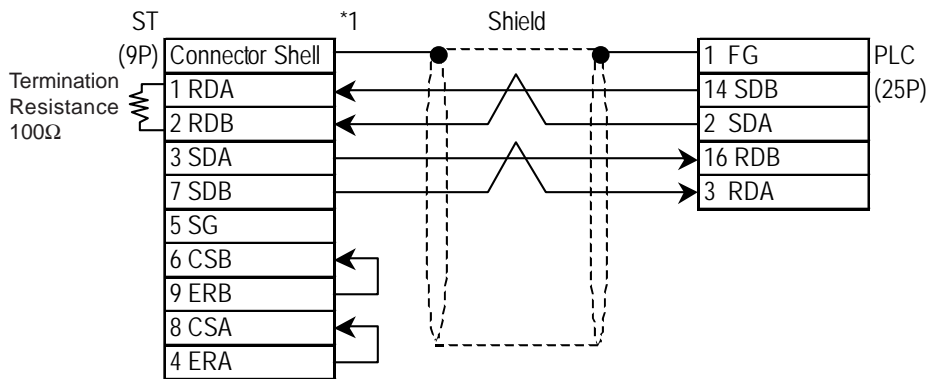

*\*1 Be sure to connect the shield to the Connector Shell. For information about FG connections, refer to page 1-2 "RS422 I/F (ST400)" section's Note, in the "Connecting a Device/PLC to the ST unit."*

## Cable Diagram 6

### GP/GLC Series Units

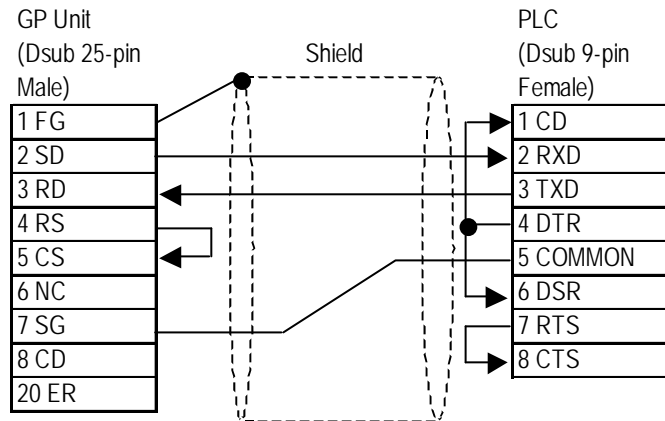

- Note:**
- Connect the shield to the GP's FG terminal.
  - If a communications cable is used, it must be connected to the SG terminal and COMMON terminal.

### ST401 Unit

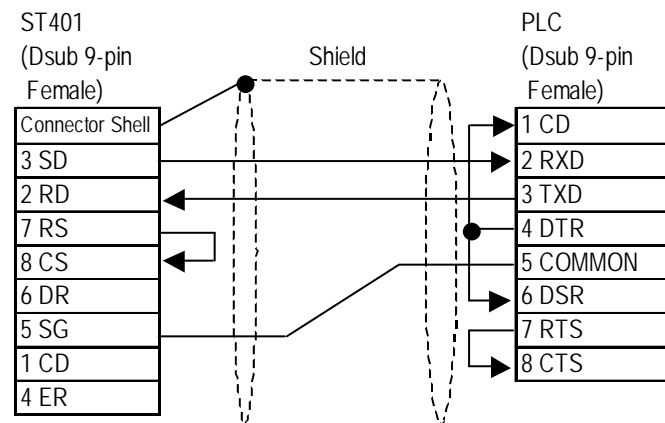

- Note:**
- Connect the shield to the GP's FG terminal.
  - If a communications cable is used, it must be connected to the SG terminal and COMMON terminal.

**Cable Diagram 7 (RS-232C)**

**GP/GLC Series Units**

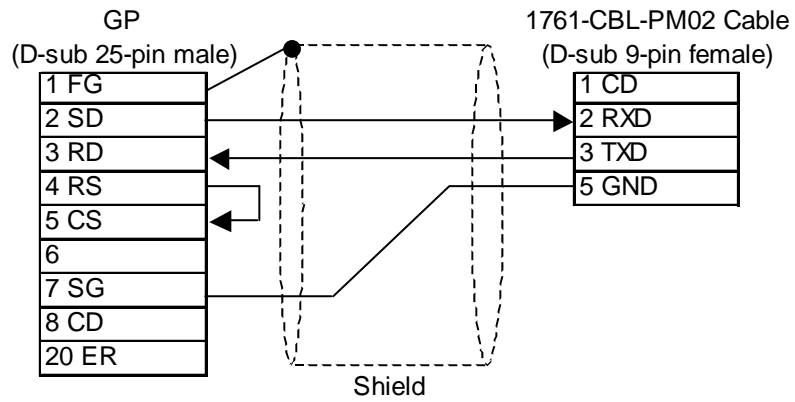

**ST401 Unit**

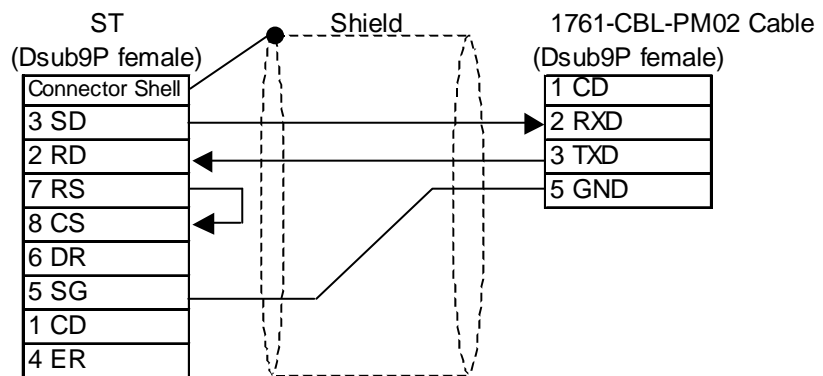

### Cable Diagram 8 (RS-232C)

#### GP/GLC Series Units

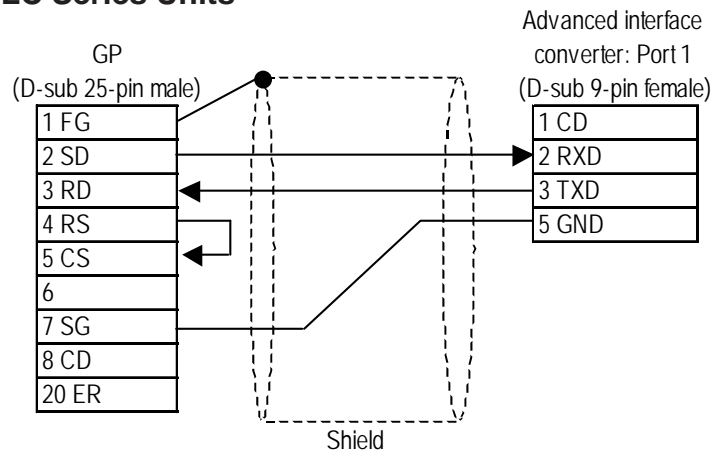

#### ST401 Unit

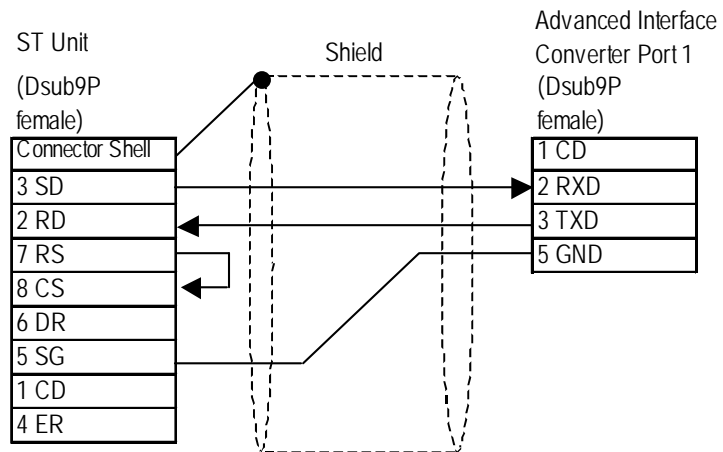



## Cable Diagram 9

### GP/GLC Series Units

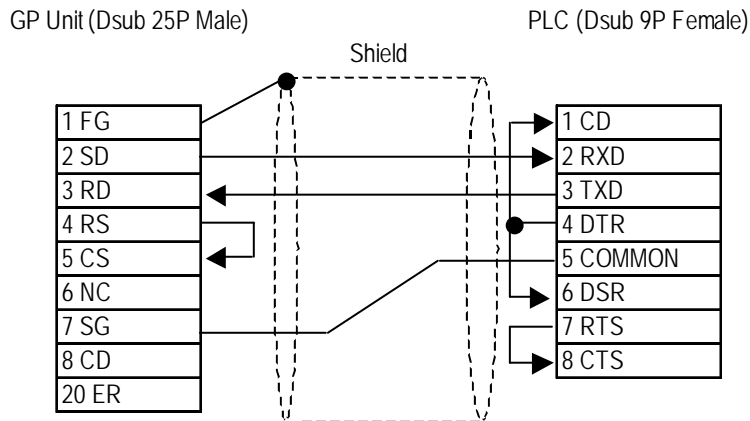

**Note:**

- Connect the shield to the GP's FG terminal.
- If a communications cable is used, it must be connected to the SG terminal and COMMON terminal.

### ST401 Unit

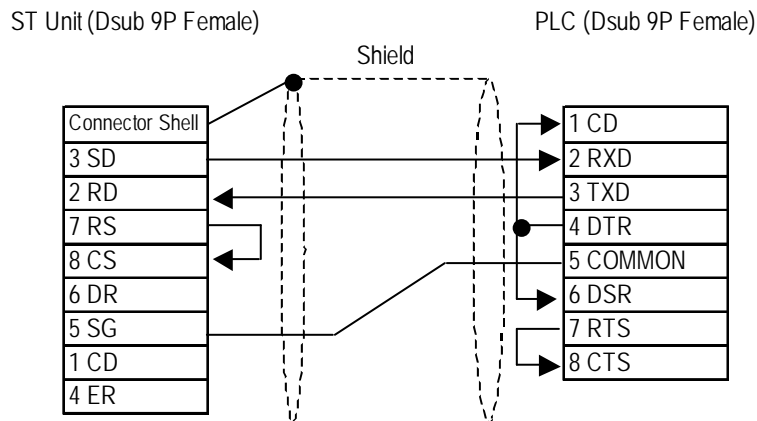

**Note:**

- Connect the shield to the GP's FG terminal.
- If a communications cable is used, it must be connected to the SG terminal and COMMON terminal.

## 2.17.3 Supported Devices

The following describes the range of devices supported by the GP.

### ■ SLC 500/MicroLogix 1000•1200•1500 Series

 Setup System Area here.

Device	Bit Address	Word Address	Particulars
Output	O:0.000/00 ~ O:63.255/15	O:0.000 ~ O:63.255	*2*3
Input	I:0.000/00 ~ I:63.255/15	I:0.000 ~ I:63.255	*2*3
Bit	B3:000/00 ~ B3:255/15	B3:000 ~ B3:255	H/L
	B9:000/00 ~ B255:255/15	B9:000 ~ B255:255	
Timer (TT: Timing Bit)	T4:000/TT ~ T4:255/TT	---	
	T9:000/TT ~ T255:255/TT		
Timer (DN: Completion Bit)	T4:000/DN ~ T4:255/DN	---	
	T9:000/DN ~ T255:255/DN		
Timer (PRE: Setup Value)	---	T4:000.PRE ~ T4:255.PRE	*1
		T9:000.PRE ~ T255:255.PRE	
Timer (ACC: Current Value)	---	T4:000.ACC ~ T4:255.ACC	*1
		T9:000.ACC ~ T255:255.ACC	
Counter (CU: Up Count)	C5:000/CU ~ C5:255/CU	---	
	C9:000/CU ~ C255:255/CU		
Counter (CD: Down Count)	C5:000/CD ~ C5:255/CD	---	
	C9:000/CD ~ C255:255/CD		
Counter (DN: Completion Bit)	C5:000/DN ~ C5:255/DN	---	
	C9:000/DN ~ C255:255/DN		
Counter (PRE: Setup Value)	---	C5:000.PRE ~ C5:255.PRE	*1
		C9:000.PRE ~ C255:255.PRE	
Counter (ACC: Current Value)	---	C5:000.ACC ~ C5:255.ACC	*1
		C9:000.ACC ~ C255:255.ACC	

*continued to next page*

\*1 When reading and writing consecutive addresses that are all two words or longer, reading will take longer than for other devices, and the overall screen refresh speed will be slower.

\*2 Not available for writes.

\*3 Within the GP70 series units, this applies only to the GP377 series.

Device	Bit Address	Word Address	Particulars	
Control (EN: Enable)	R6:000/EN ~ R6:255/EN	---	*3	
	R9:000/EN ~ R255:255/EN			
Control (EU: Enable Unload)	R6:000/EU ~ R6:255/EU	---	*3	
	R9:000/EU ~ R255:255/EU			
Control (DN: Complete Bit)	R6:000/DN ~ R6:255/DN	---	*3	
	R9:000/DN ~ R255:255/DN			
Control (EM: Empty)	R6:000/EM ~ R6:255/EM	---	*3	
	R9:000/EM ~ R255:255/EM			
Control (ER: Error)	R6:000/ER ~ R6:255/ER	---	*3	
	R9:000/ER ~ R255:255/ER			
Control (UL: Unload)	R6:000/UL ~ R6:255/UL	---	*3	
	R9:000/UL ~ R255:255/UL			
Control (IN: Inhibit Comp.)	R6:000/IN ~ R6:255/IN	---	*3	
	R9:000/IN ~ R255:255/IN			
Control (FD: Found)	R6:000/FD ~ R6:255/FD	---	*3	
	R9:000/FD ~ R255:255/FD			
Status	S2:000/00 ~ S2:163/15	S2:000 ~ S2:163	*2*3	
Integer	---	N7:000 ~ N7:255	[Bit 15]	H/L
		N9:000 ~ N255:255		
Floating point	---	F8:000 ~ F8:255		
		F9:000 ~ F255:255		
String	---	ST9:000 ~ ST255:255	*3	L/H
Long word	---	L9:000 ~ L255:255	[Bit 31] *3	
ASCII	---	A9:000 ~ A255:255	*3	

\*2 Not available for writes.

\*3 Within the GP70 series units, this applies only to the GP377 series.



- The range of available devices depends on the type of CPU used. For available device range information, refer to your PLC's manual.
- In the above tables, the address descriptions and input methods used in GP-PRO/PBIII for Windows V6.0 or earlier software may vary, however the internal data can be converted. Even if GP-PRO/PBIII for Windows V6.0 or later software is used, the internal data will not be damaged.
- When using Version 6.0 or earlier address displays and input methods with Versions 6.1 or later software, be sure to use the following steps.
  - 1) Locate and open the folder named [SLC500] in your GP/PRO/PBIII for Windows Version 6.1 or later CD-ROM.
  - 2) Copy the file named [SLC500.TBL] to the folder [PLCTBL] on your PC's hard disk drive. (This folder was created when Version 6.1 was installed.)
  - 3) Delete the [SLC500.PTO] from the folder [PTO] was created when GP-PRO/PBIII was installed.
  - 4) Start up GP-PRO/PBIII for Windows. You will now be able to use Version 6.0 or earlier address displays and input methods. When running screen editor software version 6.0 or earlier, D-Script creation or screen data modification while using [SLC500.PTO] is not possible.
- File Numbers 0~8 are the User's default files.
- A PLC COM Error (02:10) develops when a device cannot be allocated into the PLC data table map.
- According to the PLC specifications, the input and output relays cannot perform direct reads and writes. As a result, perform the following procedures via the PLC:
 

When reading data; use a ladder program to move the input and output relay data either as bits or as integers, and then read out those bits or integers.

When writing data; write the data as either bits or integers, and then use the ladder program to move the data to the input or output relays.
- In Rockwell (Allen-Bradley) PLCs, the structure of each device's data is determined from the Element; however, in GP-PRO/PBIII for Windows there is no Element. Therefore, use the following examples when entering device data.

- For word devices N, B, and F

Device Address Entry

N7:0/0

File Type: N

File Number: 7

Element: 0

Bit: 0

OK Cancel

Display after input: N7:0

- For word devices T and C

Device Address Entry

T4:0.PRE

File Type: T

File Number: 4

Element: 0

Sub-Element: PRE  
PRE  
ACC

OK Cancel

Display after input: T4:0.PRE

- For bit devices T and C

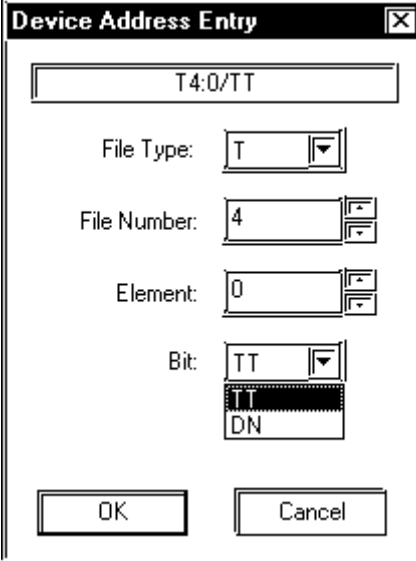

The image shows a dialog box titled "Device Address Entry" with a close button in the top right corner. At the top, there is a text field containing "T4:0/TT". Below this, there are four rows of controls:





- "File Type:" with a dropdown menu showing "T".
- "File Number:" with a text field containing "4" and a small icon to its right.
- "Element:" with a text field containing "0" and a small icon to its right.
- "Bit:" with a dropdown menu showing "TT". Below the dropdown, there is a small grid with "TT" in the top row and "DN" in the bottom row.

At the bottom of the dialog box, there are two buttons: "OK" on the left and "Cancel" on the right.

Display after input: T4:0/TT

■ PLC-5 Series

 Setup System Area here.

Device	Bit Address	Word Address	Particulars	
Input Relay	I00000 ~ I27717	I000 ~ I277		H/L
Output Relay	O00000 ~ O27717	O000 ~ O277		
Internal Relay	B300000 ~ B6799915	B3000 ~ B67999		
Timer (TT: Timing Bit)	TT3000 ~ TT67999	---		L/H
Timer (TD: Complete Bit)	TD3000 ~ TD67999	---		
Counter (CC: Count)	CC3000 ~ CC67999	---		
Counter (CD: Complete Bit)	CD3000 ~ CD67999	---		
Timer (ACC: Current Value)	---	TA3000 ~ TA67999		
Timer (PRE: Setup Value)	---	TP3000 ~ TP67999		
Counter (ACC: Current Value)	---	CA3000 ~ CA67999		
Counter (PRE: Setup Value)	---	CP3000 ~ CP67999		
Data Register Integer	---	N3000 ~ N67999		
Data Register BCD	---	D3000 ~ D67999		
Data Register ASCII	---	A3000 ~ A67999		



- The range of supported devices may be different depending on your CPU.
- In Rockwell (Allen-Bradley) PLCs, the structure of each device data is determined from the *Element*; in GP-PRO/PBIII for Windows there is no concept called the *Element*. Use the following examples when entering device data.

PLC Data

■ When Using Elements

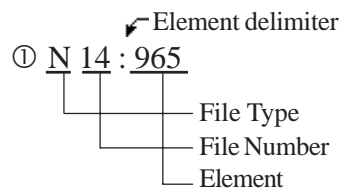

GP-PRO/PBIII Input

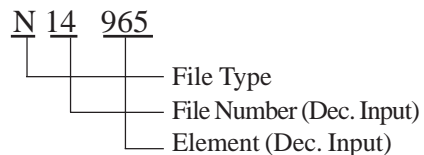

**PLC Side**

**GP-PRO/PBIII Input**

■ When Using Words

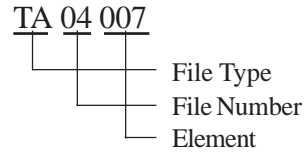
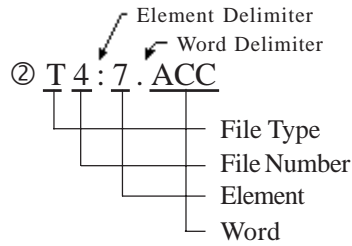

■ When Using Bits

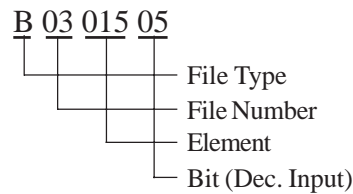
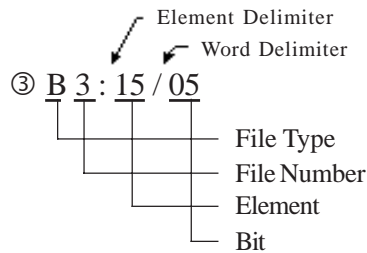

B301505 represents the same data as B3/245 (number 245 bits of file number 3). However, GP-PRO/PBIII for Windows cannot be used to input B3/245 directly.

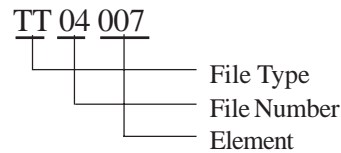
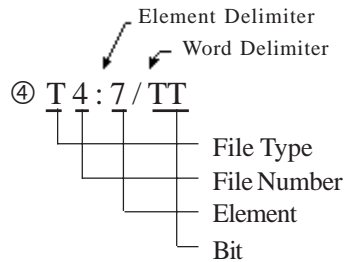

- There is no File Number for the *Input Relay* and *Output Relay*. Also, the Element and Bit Numbers are Hexadecimal.

**PLC Side**

**GP-PRO/PBIII Input**

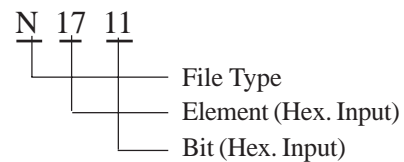
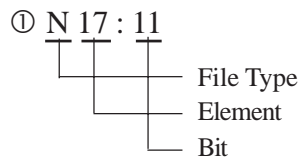



## ■ ControlLogix 5000 Series/CompactLogix 5000 Series

 Setup System Area here.

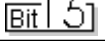
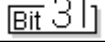
Device	Bit Address	Word Address	Particulars
Bit (BOOL)	BOOL00000000~BOOL99999931	BOOL000000~BOOL999999	*1*3
8 bit integer (SINT)	_____	SINT000000~SINT999998	 *1
16 bit integer (INT)	_____	INT000000~INT999999	 *1
32 bit integer (DINT)	_____	DINT000000~DINT999999	 *1
32 bit float (REAL)	_____	REAL000000~REAL999999	*1*2 H/L

**\*1** When using a GP Series unit to access a ControlLogix 5000/Compact Logix 5000 Series unit's data memory, you must first allocate data memory's array elements. When allocating array elements, use File numbers and Element numbers. An address designation example is shown below for GP-PRO/PBIII for Windows.

INT 123 100  
           └──┬── Element number (0~999)  
           └──┬── File number (0~999)

**\*2** This device uses Float. When this type of device is used, only the E-tag and K-tag's "32-bit Float" setting can be used.

**\*3** The BOOL device descriptions used in the GP-PRO/PBIII manual and the RSLogix 5000 manual are different. Please be aware of these differences when setting up BOOL devices.

GP-PRO/PBIII manual	000000 00~ 000000 31	000001 00~ 000001 31	000002 00~ 000002 31	~	000999 00~ 000999 31
RSLogix 5000 manual	0~31	32~63	64~95	~	31968~31999



**When using the GP to access a PLC device, be sure to first allocate all Tags used by PLC Data Memory to their respective devices. Use the Rockwell's RSLogix 5000 ladder logic software to allocate these devices.**

**If device allocation is not performed, a Host Communication Error will occur (02:D6).**

**Reference**  2.17.5 Error Codes

## Device Setting Example

The following explanation is for the ControlLogix 5000/CompactLogix 5000 device allocation.

### 1) PLC Tag Settings

Designate the Tag Name and Type.

- Tag Name : Can be set to any value. (Not related to GP device name)
- Type : Use one of the following data types for the Element setting.

(Use the same device name as the GP)

BOOL (32-bit data type)

INT (word data type)

DINT (dword data type)

SINT (byte data type)

REAL (float data type)

Example 1

Tag Name	Type
N7	INT[200]
DINT1	DINT[100]
DATA2	SINT[50]

This example's data uses the following values.

Row1 : Tag Name "N7" uses the INT data type for a 200 element array.

Row2 : Tag Name "DINT1" uses the DINT data type for a 100 element array.

Row3 : Tag Name "DATA2" uses the SINT data type for a 50 element array.

Be sure to set the number of array elements within the GP unit's maximum usable range. (The GP can access up to 999 elements.)

Also, if array elements are not designated, only one element can be used.

Ex. Tag Name:N8, Type:INT allows only one word to be used by N8.

### 2) Mapping Settings

The tag name set in 1) can have any desired file number allocated to it. It is not possible to set the same file number to two tag names.

Example 2

File Number	Tag Number
2	DATA2
1	DINT1
7	N7

**2.17.4 Environment Setup**

The following tables list Digital's recommended PLC and GP communication settings.

**■ SLC 500 Series**

GP Setup		Special Interface Module Setup	
Baud Rate	19200 bps	Baud Rate	19200 bps
Data Length	8 bits (fixed)	---	
Stop Bit	1 bit (fixed)	---	
Parity Bit	EVEN	Parity Bit	EVEN
Data Flow Control	ER Control	---	
Communication Format	RS-232C	---	
DF1Mode <sup>*3</sup> (HALF-DUPLEX)	HALF / BCC	Communication Driver	DF1 HALF-DUPLEX SLAVE
		Error Detection	BCC
DF1Mode <sup>*3</sup> (FULL-DUPLEX)	FULL / CRC	Communication Driver	DF1 FULL-DUPLEX SLAVE
		Error Detection	CRC
---		Duplicate Packet Detection	DISABLE <sup>*1</sup>
---		Control Line	No Handshaking <sup>*1</sup>
Unit No. (DH GP) <sup>*2</sup>	0	Station Address <sup>*2</sup>	0
Unit No. (DH PLC) <sup>*2</sup>	0	---	---

\* 1 Will not operate with any other settings.

\* 2 Setup the Station Address and the GP's Unit No. (DH GP) address to the same value (address set as decimal values). It is unnecessary to setup the DH PLC address.

\* 3 With the GP in offline mode, use the "Operating Environment Setup" area to set the DF1 mode.

**Reference** Specifying DH addresses

## ■ PLC-5 Series

GP Setup		CPU (CH0), 1785-KE, 1770-KF2	
Baud Rate	19200 bps	Baud Rate	19200 bps
Data Length	8 bits (fixed)	Data Length	8 bits (fixed)
Stop Bit	1 bit (fixed)	Stop Bit	1 bit (fixed)
Parity Bit	EVEN	Parity Bit	EVEN
Data Flow Control	ER Control	---	
Communication Format (RS-232C)	RS-232C	Communication Format (RS-232C)	RS-232C
Communication Format (RS-422)	4-wire type	Communication Format (RS-422)	RS-422A
DF1Mode <sup>*6</sup> (HALF-DUPLEX)	HALF / BCC	Comm. protocol	Half duplex (DF1 Slave for CH0)
		Error Check	BCC
DF1Mode <sup>*6</sup> (FULL-DUPLEX)	FULL / CRC	Comm. protocol	Full duplex (DF1 Slave for CH0)
		Error Check	CRC
---		Duplicate Detect	OFF <sup>*1</sup>
---		Control Line	NO HANDSHAKING <sup>*1</sup>
---		Other CH0 Parameters	50
---		DF1 retries	3
---		Diag file	0 (unused file)
---		RTS send delay	0
---		RTS off delay	0
---		Network link <sup>*2</sup>	Data Highway Plus
Unit No. (DH GP) <sup>*3</sup>	0	Station Address <sup>*4*5</sup> (1785-KE, 1770-KF2 side)	0

*\*1 Will not operate with any other settings.*

*\*2 This is the KF2 setup*

*\*3 Set the DH GP to station address 1785-KE or 1770-KF2, and set the DH PLC's to the CPU's station address. When using the 1785-KE or 1770-KF2, enter different numbers for the DH GP and DH PLC addresses. With a direct CPU connection, enter the same values in the DH GP and DH PLC addresses. With the GP in Offline Mode, use the "Operating Environment Setup" area to enter the DH address (DH, GP, DH, PLC) base 10 (decimal) values.*

### **Reference** Specifying DH addresses

*\*4 When using the programming unit, make sure the Terminal Address (programming equipment address) and the Station Address do not overlap.*

*\*5 Unavailable for CPU Direct Connection.*

*\*6 with the GP in offline mode, use the "Operating Environment Setup" area to set the DF1 mode.*



**When using CH0, setup the CPU to Slave. Do not setup as Point to Point.**

**■ ControlLogix 5000 Series**

GP Setup		PLC Setup	
Baud Rate	19200 bps	Baud Rate <sup>*1</sup>	19200 bps
Data Length	8 bit	Data Bits <sup>*1</sup>	8 bit
Stop Bit	1 bit	Stop Bit <sup>*1</sup>	1 bit
Parity Bit	Even	Parity <sup>*1</sup>	Even
Data Flow Control	ER	---	---
Communication Format	RS-232C	---	---
Unit No.	0	Station Address <sup>*2</sup>	0
---		Mode <sup>*1</sup>	System
---		Control Line <sup>*1</sup>	No Handshake
---		RTS Send Delay <sup>*1</sup>	0
---		RTS Off Delay <sup>*1</sup>	0
DF1Mode <sup>*3</sup> (HALF-DUPLEX)	HALF / BCC	Protocol <sup>*2</sup>	DF1Half duplex slave
		Error Detection <sup>*2</sup>	BCC
DF1Mode <sup>*3</sup> (FULL-DUPLEX)	FULL / CRC	Protocol <sup>*2</sup>	DF1Full duplex slave
		Error Detection <sup>*2</sup>	CRC
---		Transmit Retries <sup>*2</sup>	3
---		Slave Poll Timeout <sup>*2</sup>	3000

*\*1 Set via the Rockwell Ladder Logic Software RSLogix 5000 "Serial Port" menu.*

*\*2 Set via the Rockwell Ladder Logic Software RSLogix 5000 "System Protocol" menu*

*\*3 with the GP in offline mode,use the "Operrating Environment Setup" area to set the DF1 mode..*

**■ MicroLogix 1000 Series (CPU Direct Connection)**

GP Setup		PLC Setup	
Baud Rate	19200bps	Baud Rate	19200bps
Data Length	8bits	-	-
Stop Bit	1bit	-	-
Parity Bit	Non	Parity	Non
Control method	ER Control	-	-
Communication Format (RS-232C)	RS-232C	-	-
	RS-422(4-wire type)	-	-
DH Address GP	0 to 254	Node Address	0 to 254
DH Address PLC <sup>*1</sup>			
DF1Mode <sup>*2</sup> (HALF-DUPLEX)	Half/BCC	Driver	DF1 Half Duplex Slave
		Error Detection	BCC
DF1Mode <sup>*2</sup> (FULL-DUPLEX)	Full/CRC	Driver	DF1 Full Duplex Slave
		Error Detection	CRC
-	-	Control Line	No Handshaking
-	-	EOT Suppression	No check
-	-	Duplicate Packet Detect	No check
-	-	Poll Timeout	3000
-	-	Message Retries	3
-	-	Pre Transmit Delay	0

*\*1 Specify the same address for DH Node Address GP and DH Node Address PLC.*

*\*2 with the GP in offline mode,use the "Operrating Environment Setup" area to set the DF1 mode.*

### ■ MicroLogix 1200/1500 Series (CPU Direct Connection)

GP Setup		PLC Setup	
Baud Rate	19200bps	Baud Rate	19200bps
Data Length	8bit	-	-
Stop Bit	1bit	-	-
Parity Bit	EVEN	Parity	Even
Control Method	ER Control	-	-
Communication Format	RS-232C	-	-
	RS-422(4-wire type)	-	-
DH Address GP DH Address PLC *1	0 to 254	Node Address	0 to 254
Communication Format	RS-232C	-	-
DF1Mode*2 (HALF-DUPLEX)	Half/BCC	Driver	DF1 Half Duplex Slave
		Error Delection	BCC
DF1Mode*2 (FULL-DUPLEX)	Full/CRC	Driver	DF1 Full Duplex Slave
		Error Detection	CRC
-	-	Control Line	No Handshaking
-	-	EOT Suppression	OFF
-	-	Duplicate Packet Detect	OFF
-	-	Poll Timeout	3000
-	-	Message Retries	3
-	-	Pre Transmit Delay	0

\*1 Specify the same address for DH Node Address GP and DH Node Address PLC.

\*2 with the GP in offline mode, use the "Operrating Environment Setup" area to set the DF1 mode

### ■ MicroLogix 1000/1200/1500 Series (Using Advanced Interface Converter)

GP Setup		PLC Setup	
Baud Rate	19200 bps	Baud Rate	Auto
Data Length	8 bits	_____	_____
Stop Bit	1 bit	_____	_____
Parity Bit	Non	_____	_____
Control Method	ER Control	_____	_____
Communication Format	RS-232C	_____	_____
	RS-422 (4-wire type)	_____	_____
DH Address GP DH Address PLC *1	0 to 254	_____	_____

\*1 Specify the same address for DH Node Address GP and DH Node Address PLC.

## ■ Specifying DH addresses

Set up the operating environment at the initial setup when the GP is in the OFFLINE mode.

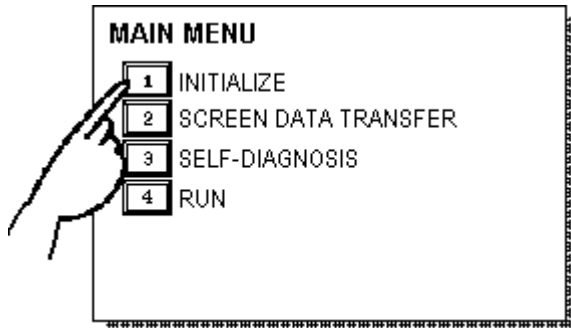

- ① Touch item #1, INITIALIZE. The INITIALIZE menu will appear.

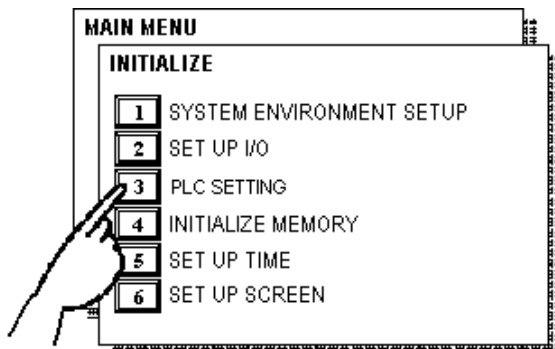

- ② Touch item #3, PLC SETTING. The PLC SETTING menu will appear.

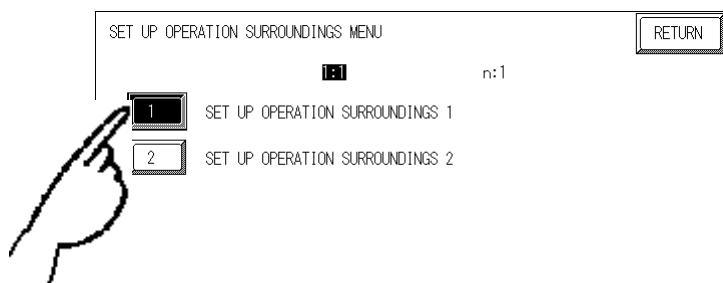

- ③ Touch selection [1:1] and then item #1, SET UP OPERATION SURROUNDINGS 1. The selected option is then highlighted.

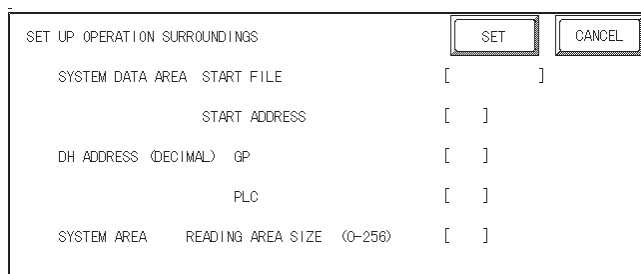

- ④ Specify the DH addresses. Then, touch [SET].

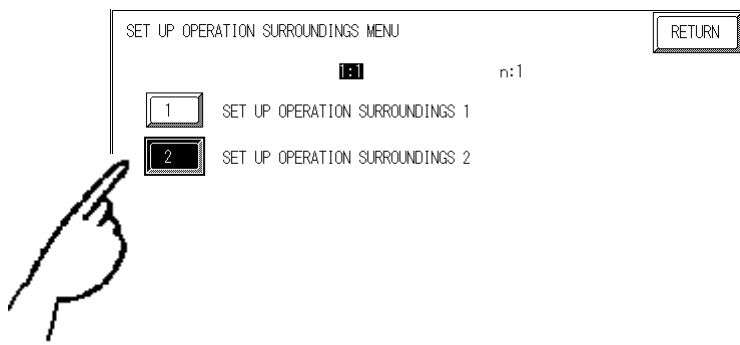

- ⑤ Touch item #2, SET UP OPERATION SURROUNDINGS 2.

Within the GP70 series units, this applies only to the GP377 series.

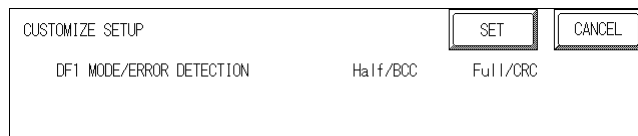

- ⑥ Specify [Error Detection] and [DF1 mode]. Then, touch [SET].

### ■ CompactLogix 5000 Series

GP Setup		PLC Setup	
Baud Rate	19200bps <sup>*1</sup>	Baud Rate <sup>*3</sup>	19200 bps
Data Length	8 bits	Data Bits <sup>*3</sup>	8 bits
Stop Bit	1 bit	Stop Bit <sup>*3</sup>	1 bit
Parity Bit	Even	Parity <sup>*3</sup>	Even
Data Flow Control	ER	-	-
Communication Format	RS-232C	-	-
Unit No.	0 <sup>*2</sup>	Station Address <sup>*4</sup>	0
-	-	Mode <sup>*3</sup>	System
-	-	Control Line <sup>*3</sup>	No Handshake
-	-	RTS Send Delay <sup>*3</sup>	0
-	-	RTS Off Delay <sup>*3</sup>	0
DF1 Mode <sup>*5</sup> (HALF-DUPLEX)	Half/BCC	Protocol <sup>*4</sup>	DF1 Half Duplex Slave
		Error Detection	BCC
DF1 Mode <sup>*5</sup> (FULL-DUPLEX)	Full/CRC	Protocol <sup>*4</sup>	DF1 Full Duplex Slave
		Error Detection	CRC
-	-	Transmit Retries <sup>*4</sup>	3
-	-	Slave Poll Timeout <sup>*4</sup>	3000
-	-	EOT Suppression <sup>*4</sup>	No Check
-	-	Enable Duplicate Detection <sup>*4</sup>	No Check (Disable)

*\*1 Data communication can be performed at 38400bps.*

*\*2 Unit numbers can be set from 0 to 254.*

*\*3 Set via the Rockwell Ladder Logic Software RSLogix 5000 "Serial Port" menu.*

*\*4 Set via the Rockwell Ladder Logic Software RSLogix 5000 "System Protocol" menu.*

*\*5 with the GP in offline mode, use the "Operrating Environment Setup" area to set the DF1 mode.*



## 2.17.5 Error Codes

### ■ PLC Error Codes

Controller error codes are represented by the "Host communication error (02:\*\*)", and indicated in the left lower corner of the GP screen. (\*\* stands for an error code.)

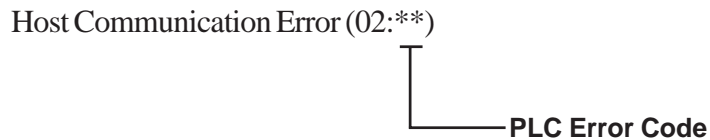

\* There are two types of PLC error codes - STS and EXT STS.

**EXT STS error codes have the characters "0xD0" attached to them, to prevent them from overlapping with STS error codes. Thus, all error codes with the last characters of "0xCF" or earlier are STS error codes.**

**Ex.**

**When a (02:D2) Host Communication Error occurs, it becomes the EXT STS error code of "0xD2".**

**When a (02:C0) Host Communication Error occurs, it becomes the STS error code of "0xC0".**