

Device/PLC Connection Manuals



About the Device/PLC Connection Manuals

Prior to reading these manuals and setting up your device, be sure to read the "Important: Prior to reading the Device/PLC Connection manual" information. Also, be sure to download the "Preface for Trademark Rights, List of Units Supported, How to Read Manuals and Documentation Conventions" PDF file. Furthermore, be sure to keep all manual-related data in a safe, easy-to-find location.

5.3 Hitachi Industrial Equipment Systems



5.3.1 System Structure

The following describes the system structure for connecting the GP to Hitachi Industrial Equipment System PLCs.

Reference The Cable Diagrams mentioned in the following tables are listed in the section titled "5.3.2 Cable Diagrams".

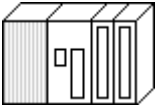
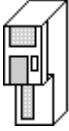

■ HIDIC H Series (using Link I/F)

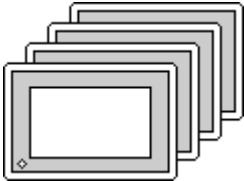
Procedure 1 for transmission control

CPU	Link I/F	Cable Diagram	GP
	 COMM Module		
H-2000 (CPU-20Ha), H-2002 (CPU2-20H) H-302 (CPU2-03H) H-702 (CPU2-07H) H-4010 (CPU3-40H)	COMM-H COMM-2H COMM-2H	(Cable Diagram 1)	GP Series

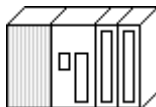
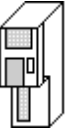

■ HIDIC H Series/COMM-2H (using Link I/F)

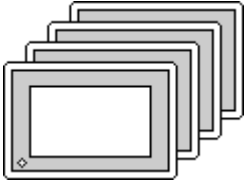
Procedure 2 for transmission control

CPU	Link I/F	Cable Diagram	GP
	 COMM Module		
H-302 (CPU2-03H) H-702 (CPU2-07H) H-2000 (CPU-20Ha) H-2002 (CPU-20H)	COMM-2H	(Cable Diagram 1)	GP Series

■ HIDIC H Series / EH-SIO (using Link I/F)

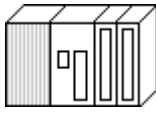
Procedure 1 for transmission control

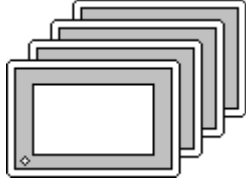

CPU *1	Link I/F	Cable Diagram	GP
	Serial Communication Module 		
EH-CPU516 EH-CPU548	EH-SIO *2	RS-422 <Cable Diagram 4>	GP/GLC Series ST400/ST403

*1 The ROM versions of the connectable EH-CPU are as follows;
EH-CPU516: Ver.E2.07 and more, EH-CPU548: Ver.E4.06 and more

*2 The versions of the connectable EH-SIO are as follows;
Function Software Version 2.0 and more

■ HIDIC H Series (CPU Direct Connection)

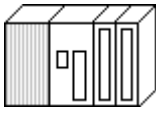
Procedure 1 and 2 for transmission control



CPU	Cable Diagram	GP
		
EH-150 (EH-CPU448, EH-CPU308A, EH-CPU316A, EH-CPU448A, EH-CPU516, EH-CPU548) *1*2	(Cable Diagram 2)	GP Series

*1 Connect to the CPU module's Serial Port 1.

*2 When connecting to a GP, a Hitachi Industrial Equipment System EH-RS05,a conversion cable is required between the modular jack (8-pin) and the Dsub connector (15-pin) are required.

■ MICRO-EH (Port 2 on CPU)

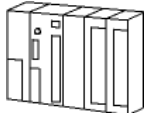
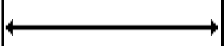
Procedures 1 and 2 for transmission control

CPU	Cable Diagram	GP
		
MICRO-EH (EH-A23□□□, EH-A28□□□, EH-D28□□□) *1	(Cable Diagram 3)	GP Series

*1 □ varies depending upon the functional specification of the CPU.

5.3.2 Cable Diagrams

The cable diagrams illustrated below and the cable diagrams recommended by Hitachi Industrial Equipment System may differ, however, using these cables for PLC operation will not cause any problems.

Cable Diagram 1

- When using Digital's RS-422 connector terminal adapter GP070-CN10-O

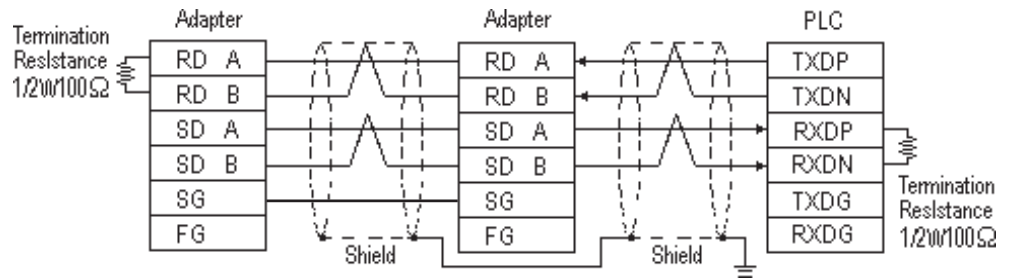

- When using Digital's Multi-link Cable, GP230-IS12-O

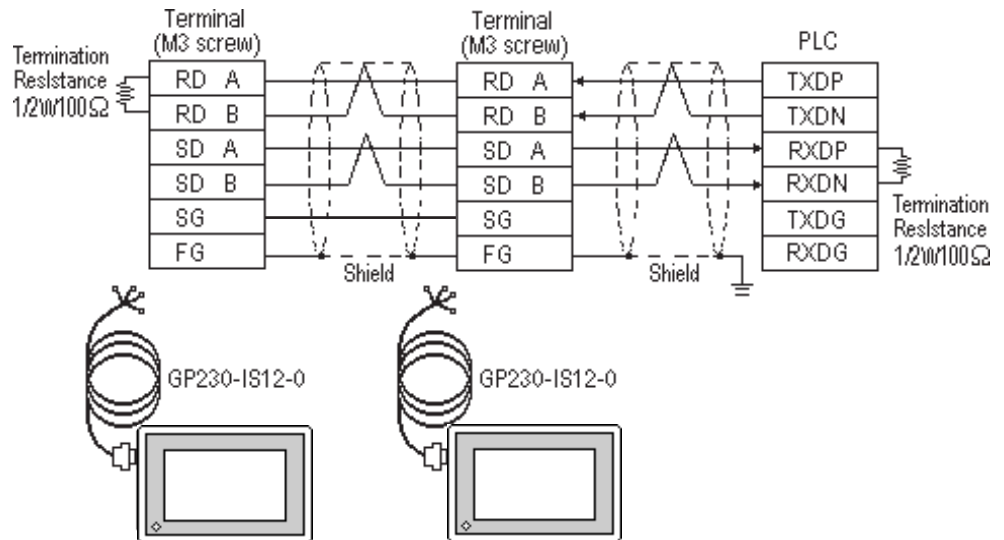

Cable Diagram 2

- When using Digital's RS-422 connector terminal adapter GP070-CN10-O

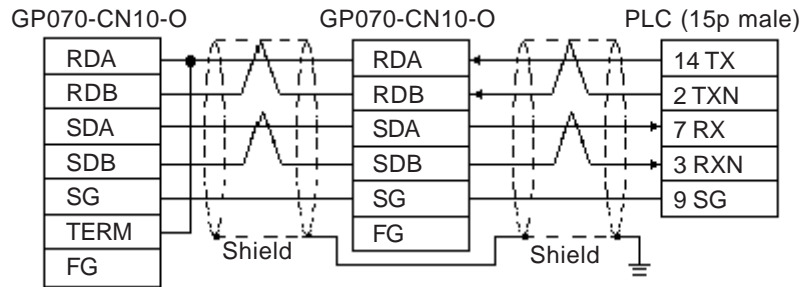

- When using Digital's Multi-link Cable, GP230-IS12-O

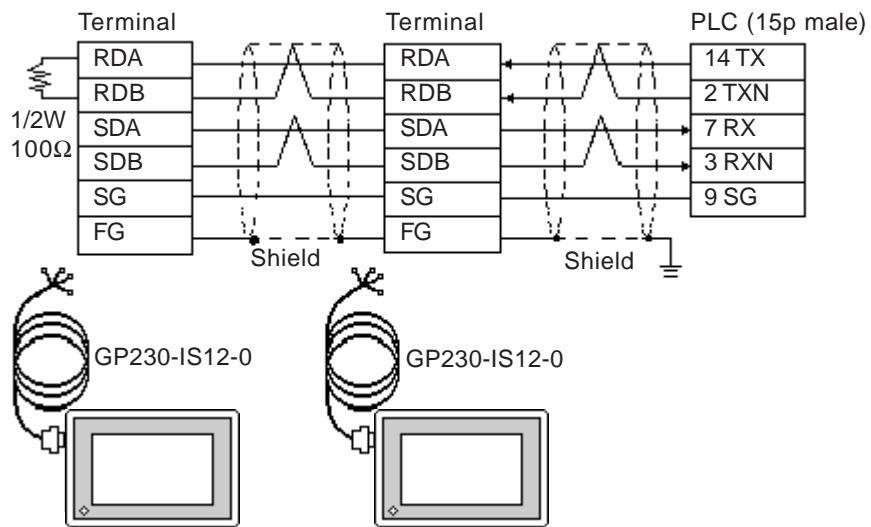

Note: For details regarding termination resistance, contact Hitachi Industrial Equipment System.

Cable Diagram 3 (RS-422 4-wire type)

- When using Digital's RS-422 connector terminal adapter GP070-CN10-O

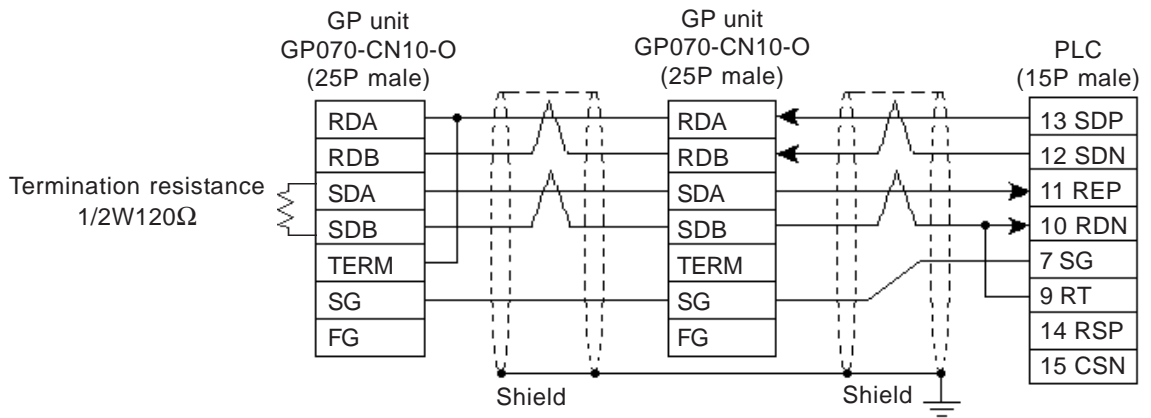

- When using Digital's Multi-link Cable, GP230-IS12-O

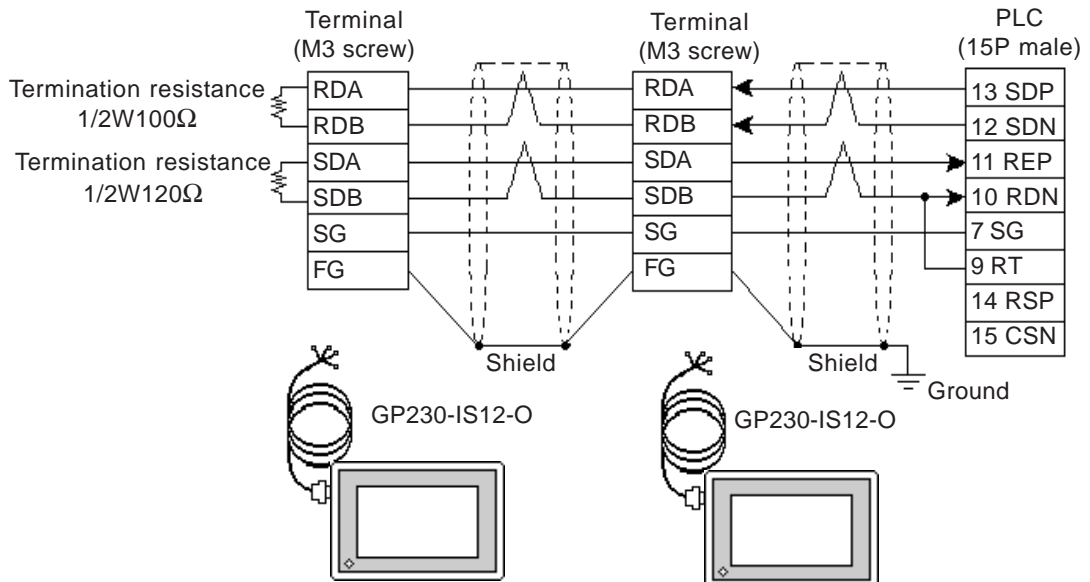



Ground your PLC's FG terminal according to your country's applicable standard. For details, refer to the corresponding PLC manual.



- Pull out a small amount of the Transfer Cable's shield, make a wire out of it and connect it to the PLC's FG terminal.
- The GP230-IS12-O Cable FG terminal is not connected to the GP's FG.
- Place a Termination Resistor at both ends of the cable.
- When using the COMM module, set its mode No. to "2".
- If an error occurs during data transmission, the program will be "retried" (resent), thereby delaying the occurrence/display of a transmission error until the retrying is finished.
- If the GP and the PLC's program consoles are operated simultaneously, the GP may generate a [Host SIO error (02: 37)] and the GPCL may generate a [CPU Exclusive Use Error]. In this case, the GP will automatically restart. The GPCL should be restarted.
- For the RS-422 connection, use a cable length less than 250m.
- As a general rule, connect the PLC at one end of the circuit.

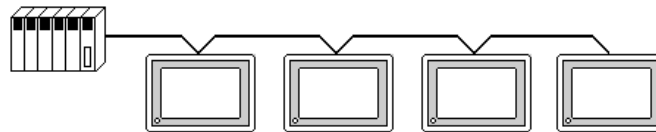

- When making your own cable connections, we recommend using Hitachi Densen's KPEV-SB-3P 0.5 mm².
- The cable connection lines are as illustrated below. The cables between the GP and the terminals should be less than 10m.

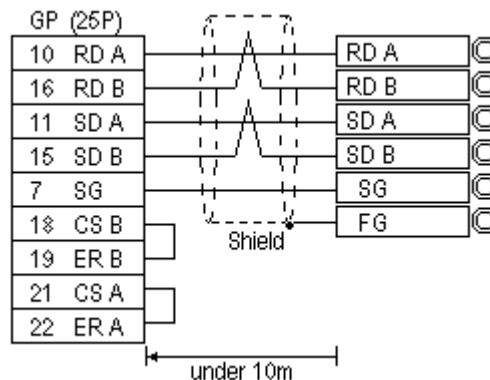

Cable Diagram 4

GP/GLC Series

- When using Digital's RS-422 connector terminal adapter GP070-CN10-O

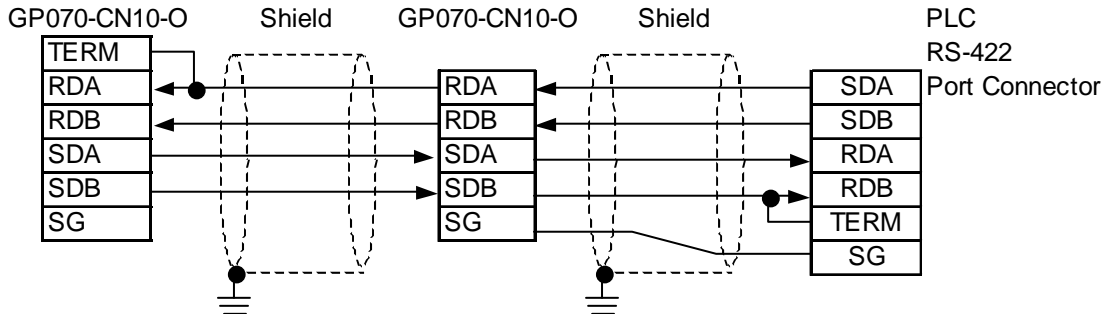

- When using Digital's Multi-link Cable, GP230-IS12-O

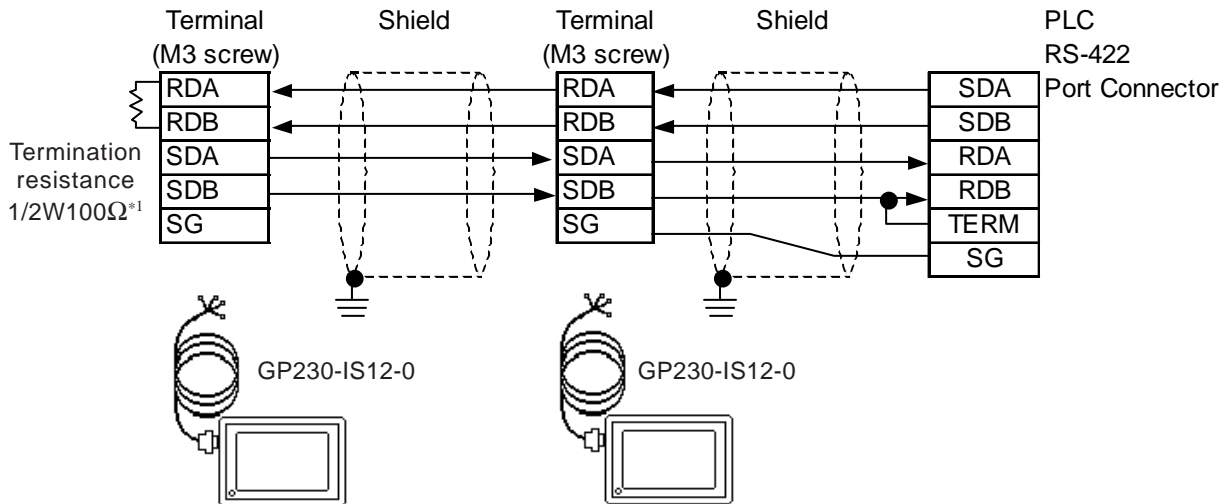

*1 Please attach the termination resistor if needed. For the details, refer to the manual of the PLC.



Note: The cable diagram of the cable that connects the GP and the terminal will be shown below.

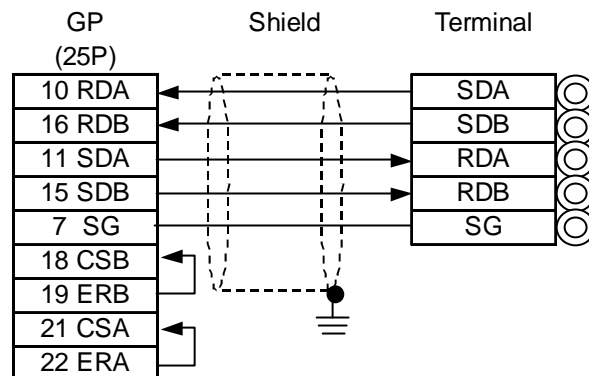

ST400/ST403 Series Units

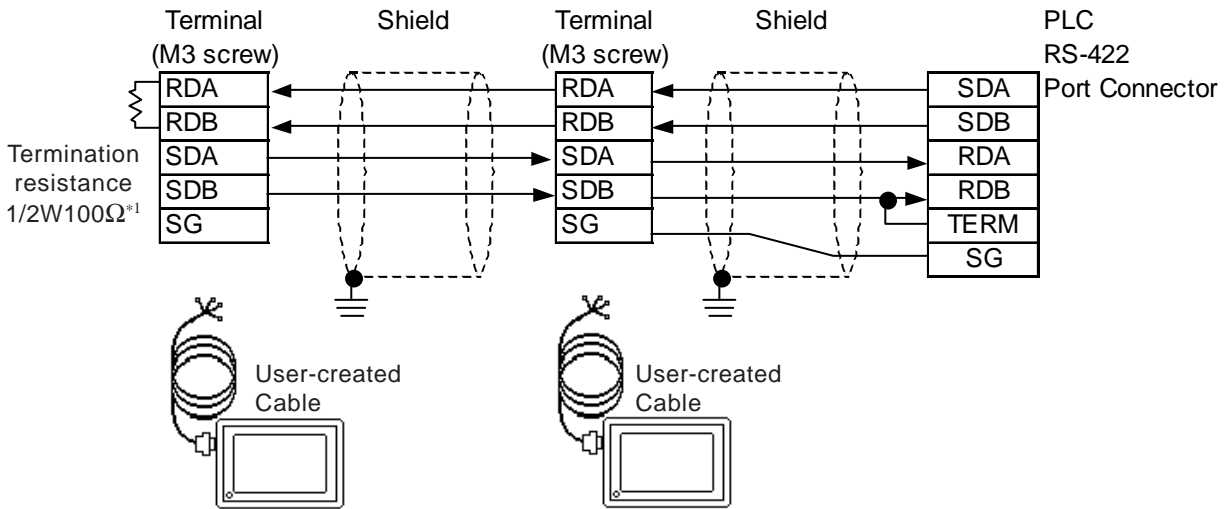

*1 Please attach the termination resistor if needed. For the details, refer to the manual of the PLC.



Note:

The cable diagram of the cable that connects the GP and the terminal will be shown below.

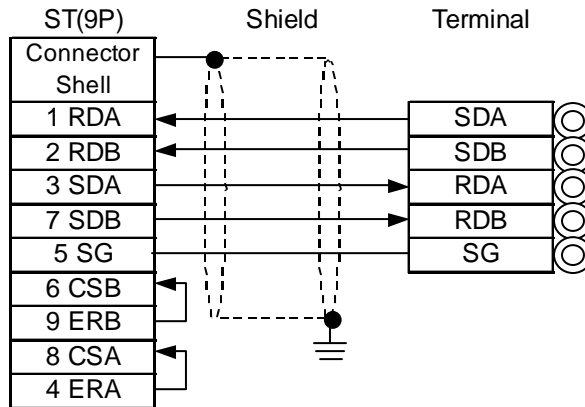

5.3.3 Supported Devices

The following describes the range of devices supported by the GP.

■ HIDIC H (HIZAC H) Series

Setup System Area or Communication Information's Storing Address here.

Device	Bit Address	Word Address	Particulars
External Input	X00000 - X05A95	WX0000 - WX05A7	*1
External Output	Y00000 - Y05A95	WY0000 - WY05A7	*1
Remote Input Relay	X10000 - X49995	WX1000 - WX4997	*2
Remote Output Relay	Y10000 - Y49995	WY1000 - WY4997	*2
Internal Output	R000 - R7BF	---	
Special Internal Output	R7C0 - R7FF	---	
CPU Link Area 1	L0000 - L3FFF	WL000 - WL3FF	
CPU Link Area 2	L10000 - L13FFF	WL1000 - WL13FF	
Data Area	M0000 - M3FFF	WM000 - WM3FF	
On Delay Timer	TD000 - TD1023	---	
Extended Timer	TM0000 - TM2047	---	
Single Shot Timer	SS000 - SS1023	---	
Watch Dog Timer	WDT000 - WDT1023	---	
Monostable Timer	MS000 - MS1023	---	
Accumulation Timer	TMR000 - TMR1023	---	
Up Counter	CU000 - CU2047	---	
Ring Counter	RCU000 - RCU2047	---	
Up/Down Counter	CT000 - CT2047	---	
Timer/Counter (Elapsed Value)	---	TC000 - TC2047	
Extended Timer (Elapsed Value)	---	TV0000 - TV2047	
Word Internal Output	---	WR0000 - WRC3FF	<input type="text"/> Bit <input type="text"/>
Word Special Internal Output	---	WRF000 - WRF1FF	<input type="text"/> Bit <input type="text"/>
Network Link Area	---	WN0000-WN7FFF	

*1 Write the data as follows.

E.g. External Input unit No. 1, Slot No. 2, Module Bit No. 34

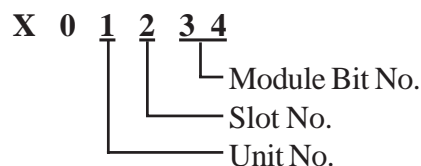

E.g. External Input unit No. 1, Slot No. 2, Module Word No. 3.

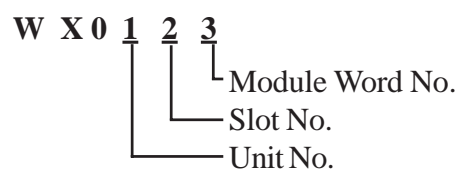

*2 Write your data as follows.

E.g. *Remote Input* Remote Master No. 1, Remote Slave No. 2, Slot No. 3, Module Bit No. 45

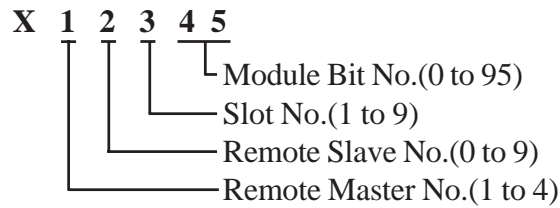

E.g. *External Input* Remote Master No. 1, Remote Slave No. 2, Slot No. 3, Module Word No. 4.

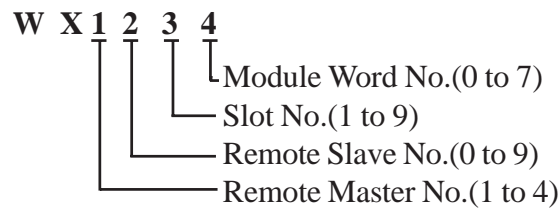

- **If the first CPU link (L0000 to L3FFF) and the second CPU link (L10000 to L13FFF) are used with any GP-PRO/PB III for Windows drawing software Ver. 1.0, enter L00000 to L03FFF for the first CPU link; and enter L100000 to L103FFF for the second CPU link by adding a zero to each one.**
- **If you use Ver. 2.0 or later GP-PRO/PB III for Windows screen editor software is used, enter the addresses shown in the previous page's table.**
- **If you upgrade your GP-PRO/PB III for Windows Ver. 1.0 software to Ver. 2.0 or later, your internal data will not be affected. Only the input method will change.**
- **The device type, the applicable range, and the ability or disability of writing may be different depending upon your CPU. Check with the manual for your CPU before use.**

5.3.4 Environment Setup

The following lists Digital's recommended PLC and GP communication settings.

■ HIDIC H Series Procedure 1 for transmission control

GP Setup		COMM Module Setup	
Baud Rate	19200 bps	Baud Rate	19200 bps
Data Length	7 bits	Data Bit	7 bits
Stop Bit	1 bit	Stop Bit	1 bit
Parity Bit	Even	Parity Bit	Even
Data Flow Control	ER Control	---	
Communication Format	4-wire type	Channel Setup	RS-422
		Mode Setup	2
---		Sum Check	Yes
Unit. No.	1	Station Number Setting	1

■ HIDIC H Series/COMM-2H Procedure 2 for transmission control

GP Setup		COMM Module Setup	
Baud Rate	19200 bps	Baud Rate	19200 bps
Data Length	7 bits	Data Bit	7 bits
Stop Bit	1 bit	Stop Bit	1 bit
Parity Bit	Even	Parity Bit	Even
Data Flow Control	ER Control	---	
Communication Format	4-wire type	Channel Setup	RS-422
		Mode Setup	9
---		Sum Check	Yes
Unit. No.	1	Station Number Setting	1

■ **HIDIC EH150 Series** Procedure 1 for transmission control

GP Setup		PLC Setup	
Baud Rate	19200 bps	Baud Rate ^{*1}	19200 bps
Data Length	7 bits	Data Bit	7 bits
Stop Bit	1 bit	Stop Bit	1 bit
Parity Bit	Even	Parity Bit	Even
Data Flow Control	ER Control	---	
Communication Format	4-wire type	Mode Setting Switch	SW1 : OFF (Normal mode)
			SW5 : ON (Exclusive mode)
			SW7 : OFF (Normal Operation mode)
			SW8 : OFF (Normal Operation mode)
---		Exclusive Port Setting	Special Internal Output set to WRF037 ^{*3}
Unit No.	0	---	

**1 Set the Mode Setting Switch. (SW3, 4 : Port 1 setting)*

**2 Depending on the your Interface and Procedure, varies as shown below.
RS-422 Procedure 1 with unit No. : A1xxH (xx indicates GP's Unit No.)
RS-422 Procedure 2 with unit No. : E1xxH (xx indicates GP's Unit No.)*

■ **MICRO-EH Series**

GP Setup		PLC Setup	
Baud Rate	19200 bps	Baud Rate	19200 bps
Data Length	7 bits (fixed)	---	---
Stop Bit	1 bit (fixed)	---	---
Parity Bit	Even (fixed)	---	---
Data Flow Control	ER Control	---	---
Communication Format	4-wire type	---	---
Unit No.	0	---	---
---	---	Port 2 Setup	Special Internal Output Set to WRF03D ^{*1}

**1 Transmission control procedure 1 (with station number) (192000 bps): A200H
Transmission control procedure 2 (with station number) (192000 bps): E200H*

■ HIDIC EH150 Series / EH-SIO

Procedure 1 for transmission control

GP Settings		PLC Settings	
Baud Rate	19200 bps	Baud Rate ^{*1}	19200 bps
Data Length	7 bits	Data Length ^{*1}	7 bits
Stop Bit	1 bit	Stop Bit ^{*1}	1 bit
Parity Bit	Even	Parity Bit ^{*1}	Even
Flow Control	ER Control	————	
Communication Format (RS-422)	4-wire type	TRANS 9 ^{*2}	WYus5 ^{*3}
————		Task Code ^{*2}	with Station No. (used to RS-422) None(Used to RS-232C)
Unit No.	0	Station No. ^{*2}	0
————		Communication Mode ^{*2}	Hi-Protocol
————		Memory cassette / ladder match	RAM-48H
————		I/O match (Unit0 / Slot0)	Word 4W / 4W

**1 Set by a dip switch. For the details, refer to the EH-SIO Manual.*

**2 Necessary to be set with the [TRANS9] command in the ladder program. For the details, refer to the EH-SIO Manual.*

**3 The contents that each mark means are as follows;(For the details, refer to the EH-SIO Manual.*

u: Unit No., s: Slot No., 5: Port 2 Set

◆ **Serial Communication Module EH-SIO**

The PLC's ladder program is required for the GP's communicating with the EH-SIO.



Note: For the detailed settings, refer to the manual of the EH-SIO or the ladder software.

The sample ladder will be shown below.

[PLC Settings]

Module Slot No. :0
 Unit No. :0
 Port 1 is specified
 Station No. :0
 Task Code :None
 Communication Mode :Hi-Protocol

[Sample Ladder Program]

