

Device/PLC Connection Manuals



About the Device/PLC Connection Manuals

Prior to reading these manuals and setting up your device, be sure to read the "Important: Prior to reading the Device/PLC Connection manual" information. Also, be sure to download the "Preface for Trademark Rights, List of Units Supported, How to Read Manuals and Documentation Conventions" PDF file. Furthermore, be sure to keep all manual-related data in a safe, easy-to-find location.





2.4 Yaskawa Electric

2.4.1 System Structure

The following describes the system structure for connecting the GP to Yaskawa PLCs.

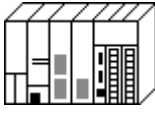
Reference *The Cable Diagrams mentioned in the following tables are listed in the section titled "2.4.2 Cable Diagrams".*

■ Memocon-SC Series (using Link I/F)



CPU	Link I/F	Cable Diagram	Cables	GP
	 SIO Module			
U84, 84J	JAMSC-C8110	RS-232C (Cable Diagram 1)	Yaskawa Electric Corp's memory bus cable JZMSZ-W1015-21 *1	GP series
U84S	JAMSC-C8610			
GL40S	JAMSC-IF61 JAMSC-IF41A			
GL60H, GL70H	JAMSC-IF60 JAMSC-IF61			
GL60S	JAMSC-IF60 JAMSC-IF61			
	JAMSC-IF612	RS-422 (Cable Diagram 2)		

* 1 Due to the size of its connector case, this cable cannot be used for GP-270, GP-370, GP-377 and GP-377R series.



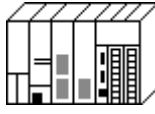

Note: Using Multiple Link I/Fs, maximum of 4 GP units can be connected at one time.

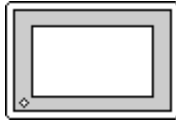
■ Memocon-SC Series (CPU Direct Connection)

CPU	Cable Diagram	Cables	GP
			
GL120	RS-232C (Cable Diagram 3)	Yaskawa Electric Corp's JZMSZ-120W0200-03	GP Series

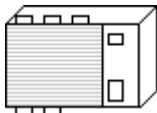
■ Control Pack Series (CPU Direct Connection)



CPU	Cable Diagram	Cables	GP
			
CP-9200 CP-9200H	RS-232C (Cable Diagram 1)	Yaskawa Electric Corp's Memo BUS Cable JZMSZ-W1015-21 ^{*2}	GP Series

- * 1 Connect to CP9200/CP9200H's machine controller (4CN, 6CN).
- * 2 Due to the size of its connector case, this cable cannot be used for GP-270, GP-370, GP-377, GP-377R series.

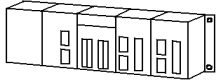

Note: Two GPs can be connected to one CP-9200/CP9200H. When using two GPs, set it up so that the System Area of the GPs do not overlap.

■ Control Pack Series (Link I/F)

CPU	Link I/F	Cables	GP
			
CP-9200SH ^{*3}	JACP-317217(CN1)	(Cable Diagram 7) (RS-232C)	GP Series
	JACP-317217(CN2)	(Cable Diagram 8) (RS-232C)	
	JACP-317217(CN3)	(Cable Diagram 9) (RS-422)	

* 3 <1:1 Connection>

The drawing shown below is for the 1:1 connection. (CN means the circuit number.)

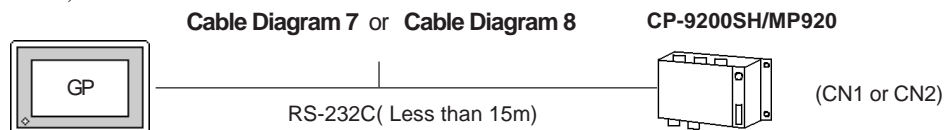

Note: CN1, CN2, CN3 can be connected at the same time, however, only one GP can be connected to one CN since it cannot use the Multi Link connection.



When connecting a GP77R series' unit to a "***_21700_*****" or an older version of a 217IF unit, set the GP-PRO/PB III software "GP settings" Area's "Send Wait Time" to 20ms. ("GP Settings" - "Communication Settings" - "Advanced...")**

< 1:n Communication >

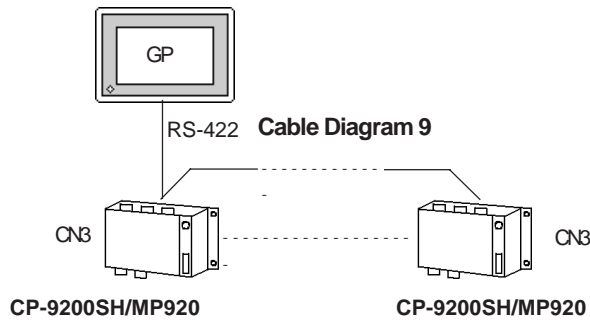

- Within this system a total of thirty two (32) CPU units can be connected to one GP. The GP is designed so that it can be connected with a maximum of thirty two (32) CPU units.
- Two GPs can be connected to one CP-9200/CP9200H. When using two GPs, set them up so that their System Areas do not overlap.

■ Memocon Micro (CPU Direct Connection)

CPU	Cable Diagram	GP
	↔	
Micro ^{*1}	RS-232C (Cable Diagram 5)	GP Series

* 1 Connect to **COM1** port.



■ PROGIC-8 Series (using CPU unit Link I/F)

CPU	Cable Diagram	Cables	GP
	↔		
PROGIC-8 ^{*1}	RS-232C (Cable Diagram 4)	Yaskawa Electric's JEPMC-W5310-03 ^{*2}	GP Series



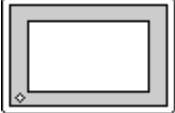

* 1 Connect to the PLC unit's **PORT1(9P)** or **PORT2(15P)**.

* 2 Can only use with **PORT1** connection; **PORT2** cannot be used because it has a 15P connector.

■ Memocon-SC Series (GL 120/GL 130) (using Link I/F)





CPU	Link I/F	Cables	GP
	Computer Link Unit 		
GL120, GL130	FAMSC-120NOM 27100	RS-422 (Cable Diagram 6)	GP Series

■ MP900 Series (using Link I/F)

CPU	Link I/F	Cable Diagram	GP
	Computer Link Unit 		
MP930	MEMOBUS Port on CPU unit (Port1, Port2)	RS-232C (Cable Diagram 7)	GP Series
MP920	MEMOBUS Port on CPU unit (Port1, Port2)	RS-232C (Cable Diagram 7)	
	JEPMC-CM200 ^{*1} (CN1,CN2)	RS-422 (Cable Diagram 9)	
	JEPMC-CM200 ^{*1} (CN3)	RS-422 (Cable Diagram 9)	

**1 Refer to the previous page's CP-9200SH data for connection details.*

■ MP2300 Series (using Link I/F)

CPU	Link I/F	Cable Diagram	GP
	Computer Link Unit 		
MP2300	General Serial Communication Module 217IF-01	RS-232C (Cable Diagram 10)	GP Series
		RS-422 1:1 Communication (Cable Diagram 11)	
		RS-422 1:n Communication (Cable Diagram 12)	
	Serial Connector on Ethernet Communication Module 218IF-01	RS-232C (Cable Diagram 10)	

2.4.2 Cable Diagrams

The cable diagrams illustrated below and the cable diagrams recommended by Yaskawa Corporation may differ. Using these cables for your PLC operations, however, will not cause any problems.



Ground your PLC's FG terminal according to your country's applicable standard. For details, refer to the corresponding PLC manual.



- **Connect the FG line of the Shield cable to either the GP or PLC, depending on your environment. When using a connector hood and grounding the FG line, be sure to use an electrical conductor. The following connection diagrams show examples for connecting a shielded cable to the PLC.**
- **For the RS-232C connection, use a cable length less than 15m.**
- **For the RS-422 connection, use a cable length less than 300m.**
- **If a communications cable is used, it must be connected to the SG (signal ground).**

Cable Diagram 1 (RS-232C)

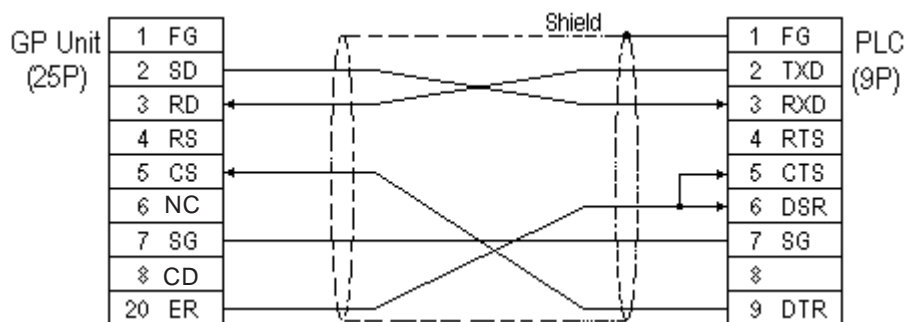

Cable Diagram 2 (RS-422)

- When using Digital's RS-422 connector terminal adapter GP070-CN10-0

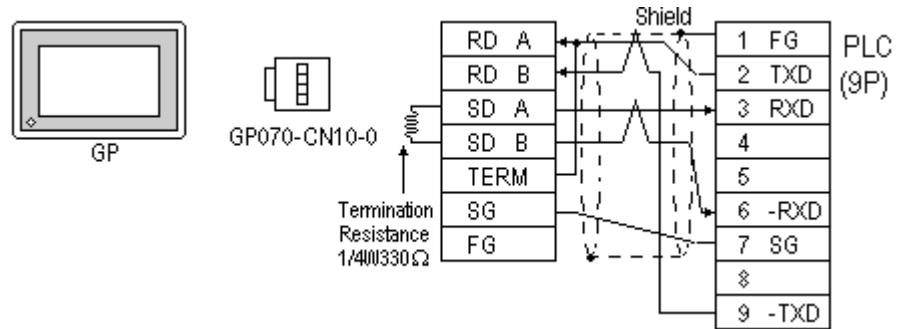

- When using Digital's RS-422 Cable, GP230-IS11-0

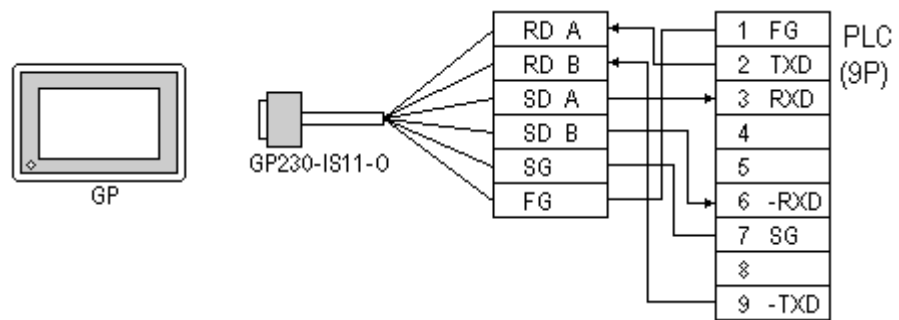

- When making your own cable connections

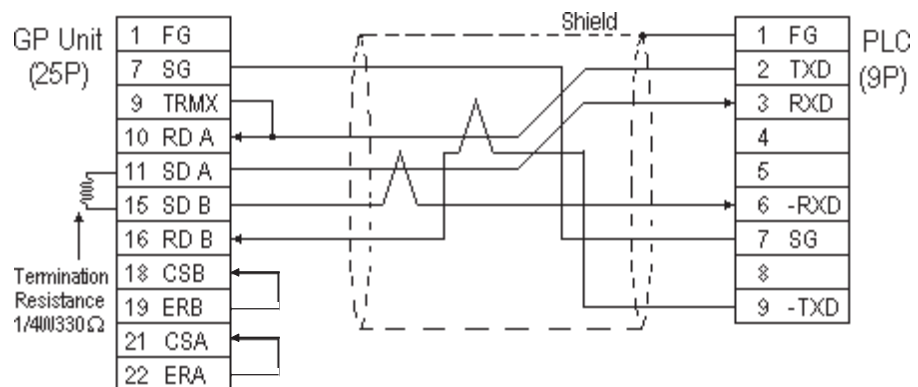

Note:

When connecting the #9 and #10 pins in the GP Serial I/F, a termination resistance of 100Ω is added between RDA and RDB.

Cable Diagram 3 (RS-232C)

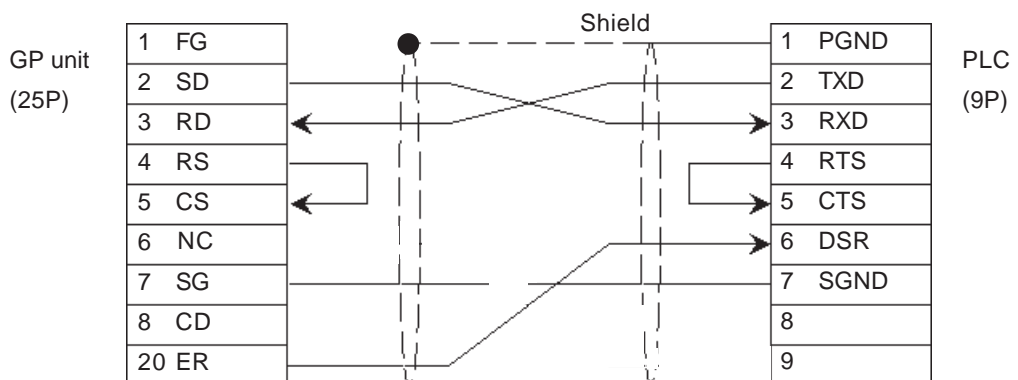

Cable Diagram 4 (RS-232C)

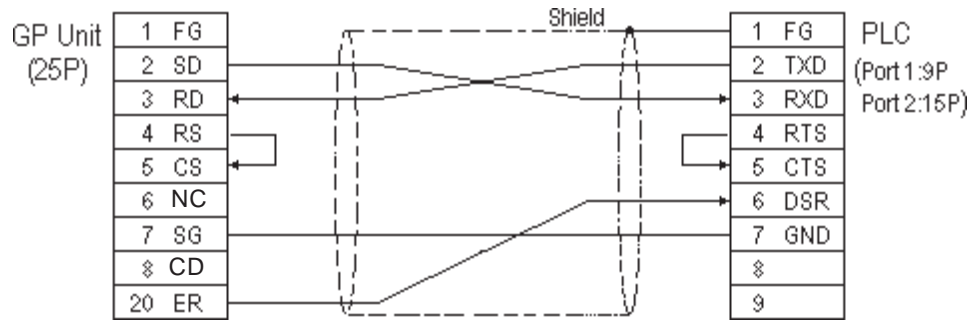

Cable Diagram 5 (RS-232C)



Note:

An RJ45 jack is used for the PLC.

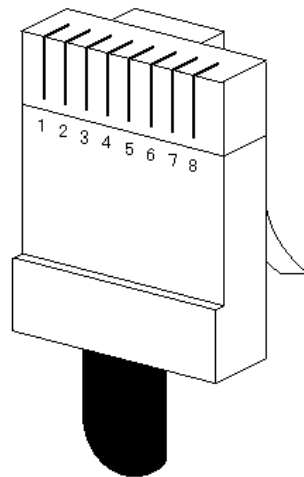

The pin numbers of the modular-jack for the connection diagrams below are based on the order described in the figure at the left.

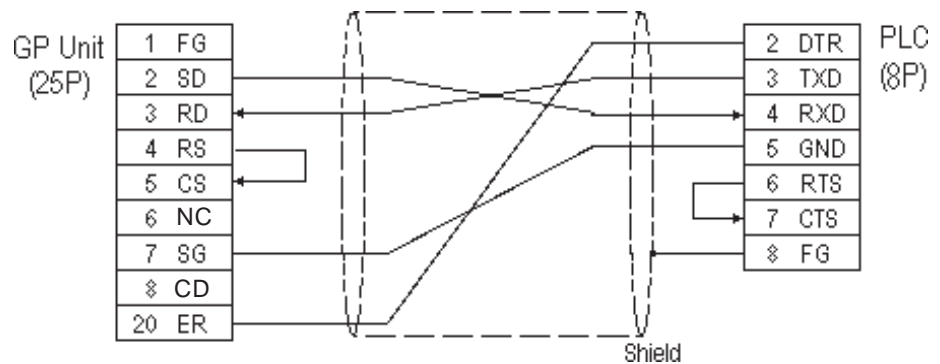

Cable Diagram 6 (RS-422)

- When using Digital's RS-422 connector terminal adapter GP070-CN10-0

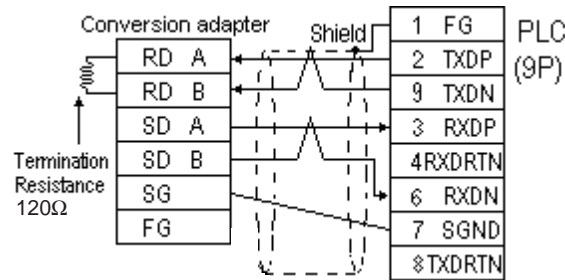

- When using Digital's RS-422 Cable, GP230-IS11-0

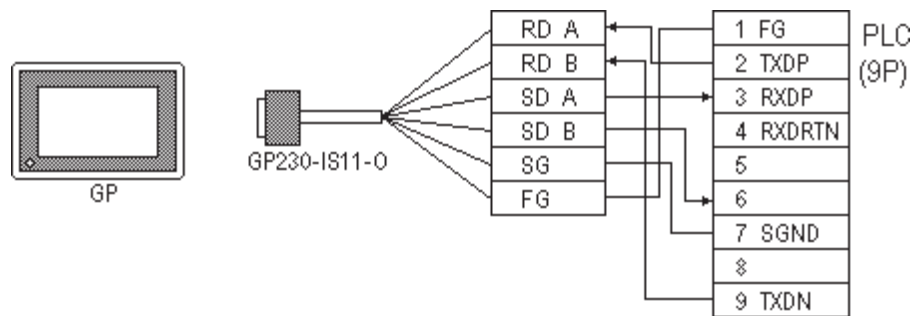

- When making your own cable connections

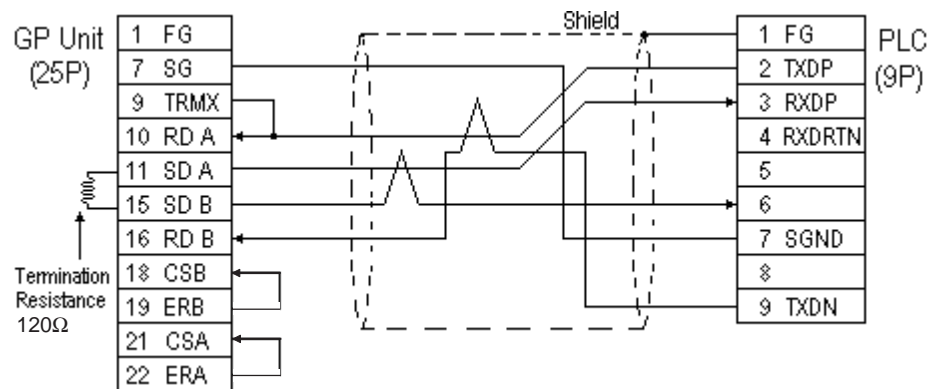

Note: When connecting the #9 and #10 pins in the GP Serial I/F, a termination resistance of 100Ω is added between RDA and RDB.

Cable Diagram 7 (RS-232C)

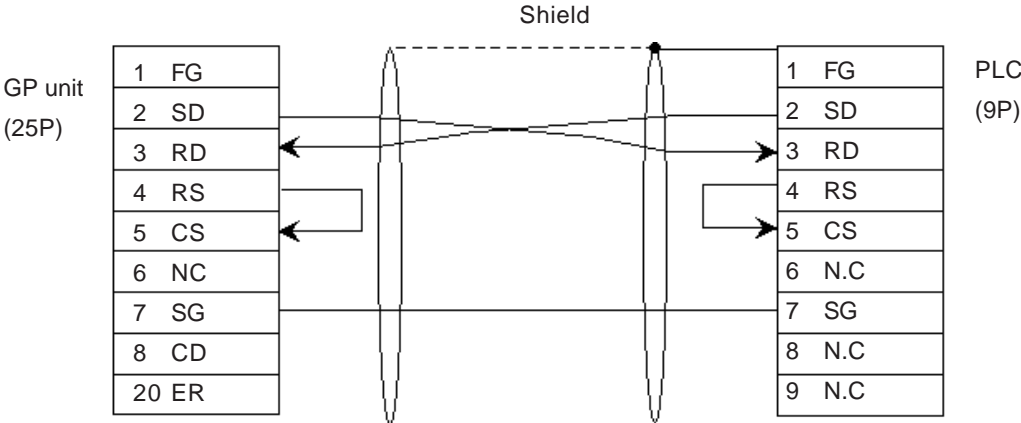

Cable Diagram 8 (RS-232C)

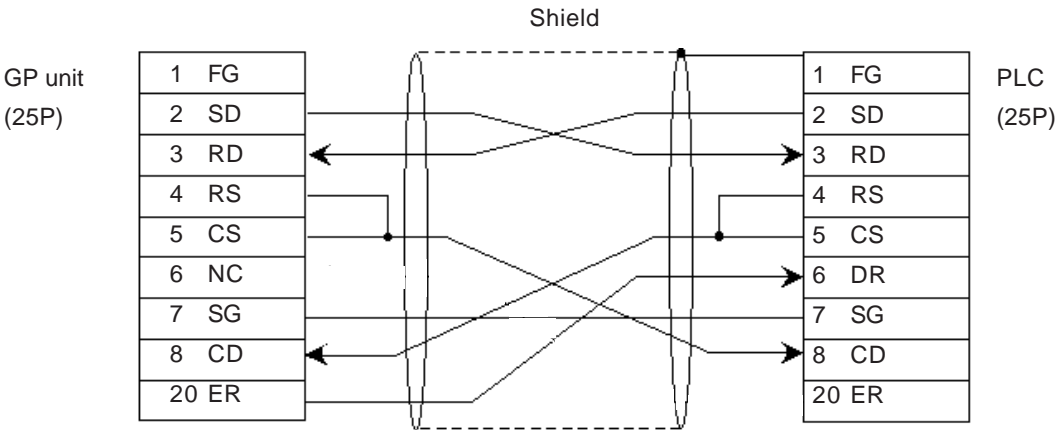

Cable Diagram 9 (RS-422)

- When using Digital's RS-422 Connector terminal adapter GP070-CN10-O.

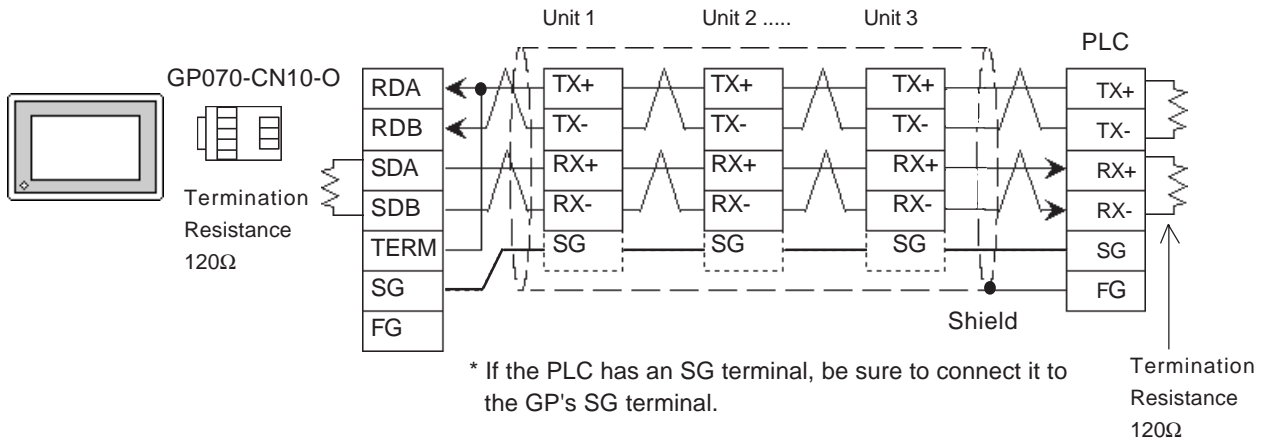

- When using Digital's RS-422 Cable, GP230-IS11-O.

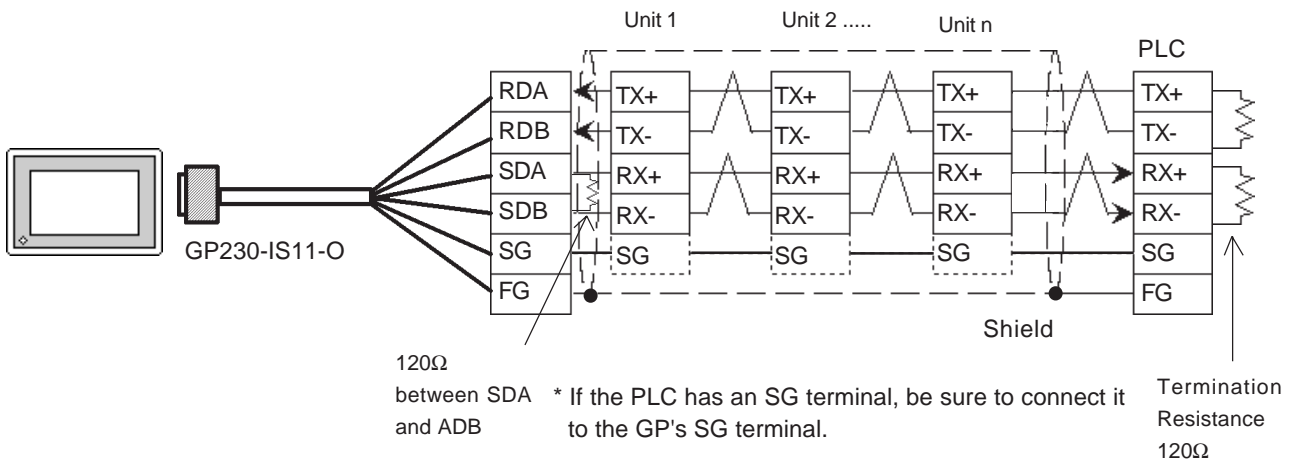

- When making your own cable connections

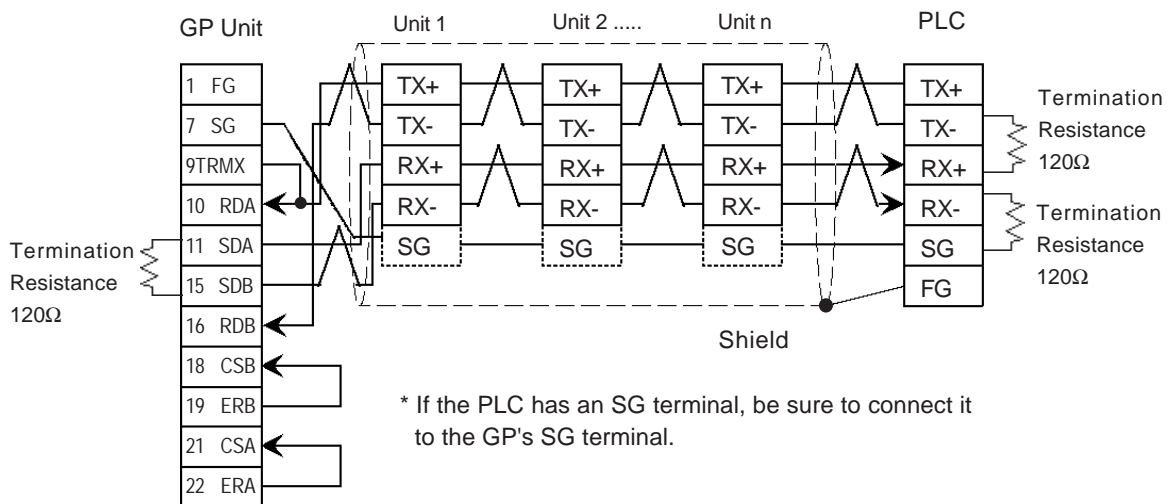

Cable Diagram 10 (RS-232C)

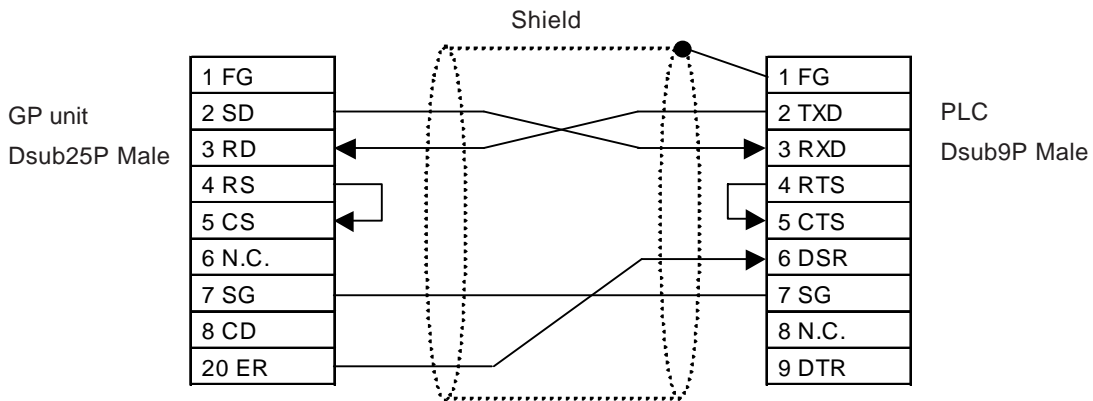

Cable Diagram 11 (RS-422)

- When using Digital's RS-422 connector terminal conversion adapter, GP070-CN10-0

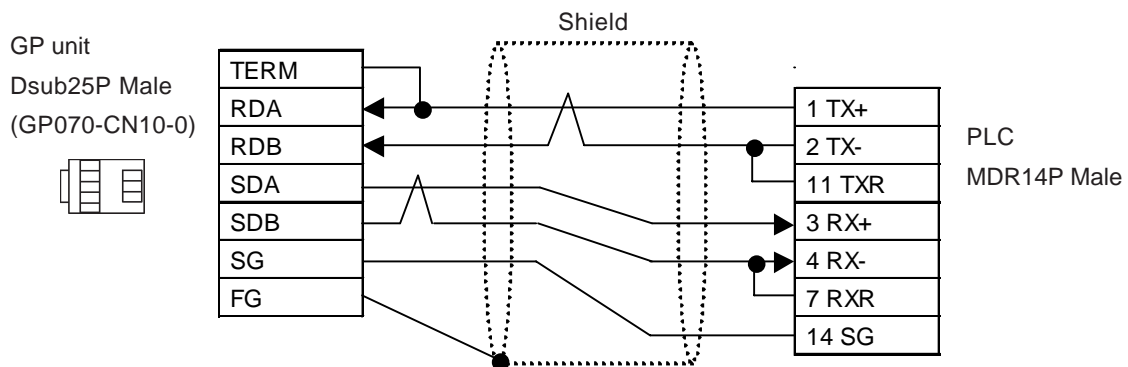

- When making your own cable connections

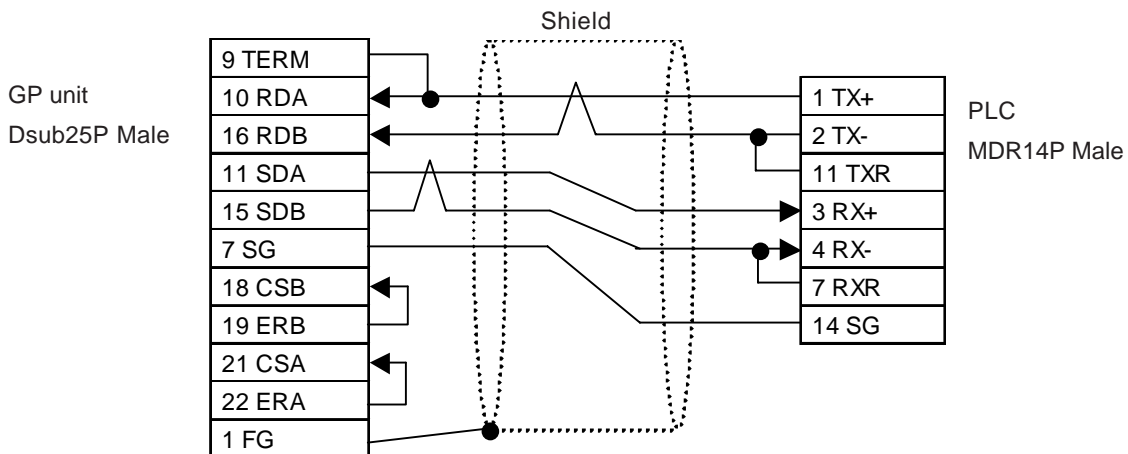

Note: Connecting TX- to TXR and RX- to RXR on the PLC side adds a termination resistance of 120Ω.

Cable Diagram 12 (RS-422)

- When using Digital's RS-422 connector terminal conversion adapter, GP070-CN10-0

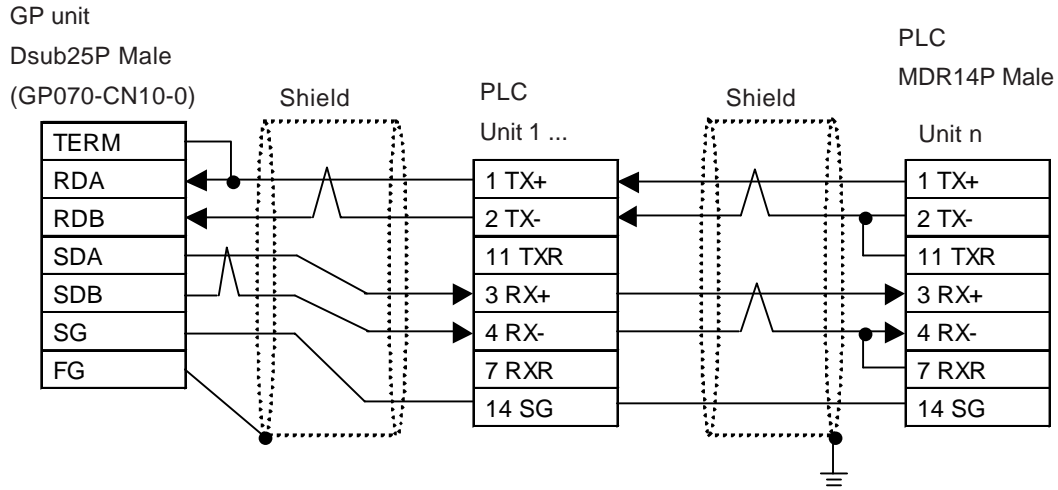

- When making your own cable connections

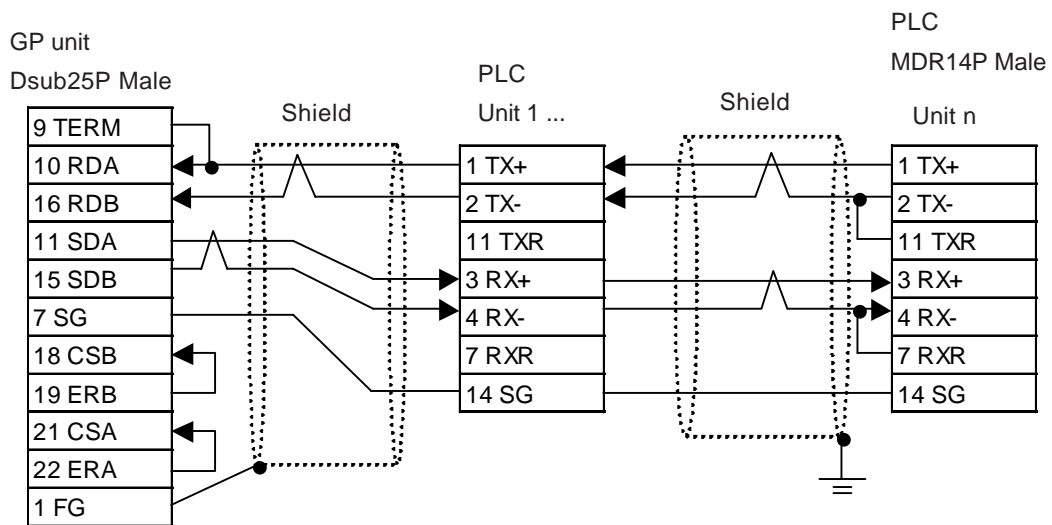

2.4.3 Supported Devices

The following describes the range of devices supported by the GP.

■ Memocon-SC Series
(U84/84J/U84S/GL40S/GL60H/GL70H/GL60S)

Setup System Area here.

Device	Bit Address	Word Address	Particulars
Coil (Output/Internal)	00001 ~ 08192	---	'1
Input Relay	10001 ~ 14096	---	'1 '2
Link Coil	D0001 ~ D1024	---	'1
Input Register	---	30001 ~ 30512	'2
Output/Keep Register	---	40001 ~ 49999	Bit 5
Link Register	---	R0001 ~ R1024	Bit 5
Constant Register	---	31001 ~ 35096	Bit 5
Extended Register	---	A0000 ~ A7FFF	Bit 7

H/L

■ Memocon-SC Series (GL120/GL130)

 Setup System Area here.

Device	Bit Address	Word Address	Particulars
Coil (Output / Internal)	000001 ~ 008192	---	*1
Input Relay	100001 ~ 101024	---	*1 *2
Link Coil 1	D10001 ~ D11024	---	*1
Link Coil 2	D20001 ~ D21024	---	*1
MC Relay 1	X10001 ~ X10256	---	*1 *2
MC Relay 2	X20001 ~ X20256	---	*1 *2
MC Coil 1	Y10001 ~ Y10256	---	*1
MC Coil 2	Y20001 ~ Y20256	---	*1
MC Code Relay 1	M10001 ~ M10096	---	*1 *2
MC Code Relay 2	M20001 ~ M20096	---	*1 *2
MC Control Relay 1	P10001 ~ P10256	---	*1 *2
MC Control Relay 2	P20001 ~ P20256	---	*1 *2
MC Control Coil 1	Q10001 ~ Q10256	---	*1
MC Control Coil 2	Q20001 ~ Q20256	---	*2
Input Register	---	300001 ~ 300512	Bit 1 5 *2
Output Register	---	300001 ~ 300512	Bit 1 5
Keep Register	---	400001 ~ 409999	Bit 1 5
Link Register 1	---	R10001 ~ R11024	Bit 1 5
Link Register 2	---	R20001 ~ R21024	Bit 1 5
Constant Register	---	700001 ~ 704096	Bit 1 5

H/L

*1 Can also specify as a word (16 bit) data.

*2 Cannot perform data write.

■ Control Pack Series

Setup System Area here.

Device	Bit Address	CP-9200/CP-9200H's Register No. Corresponding to Address	Particulars
Input Register	00001 ~ 02048	IB00000 ~ IB007FF	"1" rowspan="3">L/H
Output Register	02049 ~ 04096	OB00000 ~ OB007FF	
System Register	10001 ~ 12048	SB000000 ~ SB00127F (CPU#0's S-Register)	

Device	Word Address	CP-9200/CP-9200H's Register No. Corresponding to Address	Particulars
Input Register	49744 ~ 49871	IB00000 ~ IB007FF	"1" L/H
Output Register	49872 ~ 49999	OB00000 ~ OB007FF	
System Register	30001 ~ 30256	SW00000 ~ SW00255 (CPU#0's S-Register)	
Data Register	31001 ~ 33048 (CP-9200H only)	DW00000 ~ DW02047 (CPU#1's D-Register)	
	40001 ~ 42048	DW00000 ~ DW02047 (CPU#0's D-Register)	
Common Register	42049 ~ 49743	MW00000 ~ MW07694	

* 1 Can also specify as a word (16 bit data).



- If the above devices are used in the Control Pack series, the addresses converted using the above table should be entered.
- When you wish to use a CP-9200 together with CPU#1's Data Register or the System Register, be sure to copy data to the Common Register (MW00000 ~ MW07694) first.

■ Memocon Micro

Setup System Area here.

Device	Bit Address	Word Address	Particulars
Coil (Output/Internal)	00001 ~ 01531	---	"1" H/L
Input Relay	10001 ~ 10511	---	
Input Register	---	30001 ~ 30047	
Output/Keep Register	---	40001 ~ 41871	

* 1 Can also specify as a word (16 bit) data.

■ PROGIC-8 Series

 Setup System Area here.

Device	Bit Address	Word Address	Particulars
Output Coil	O1 ~ O512	---	*1
Input Relay	I1 ~ I512	---	*1 *2
Internal Coil	N1 ~ N1536	---	*1
Link Coil	D1 ~ D1024	---	*1
Data Register	---	W1 ~ W2048	Bit 15
Data Register (1-word data)	---	SW1 ~ SW2048	Bit 15 *3
Data Register (2-word data)	---	DW1 ~ DW2048	Bit 15 *3
Input Register	---	Z1 ~ Z128	*2
Link Register	---	R1 ~ R1024	
Link (1-word data)	---	SR1 ~ SR2048	*3
Link (2-word data)	---	DR1 ~ DR2048	*3

H/L

* 1 Can also specify as a word (16 bit data)

* 2 Cannot perform data write.

* 3 A data format compatible register. This is a virtual register applicable for the data in the PLC. It uses data register (W) and link register (R). The range of data which can be handled as 1-word is -9999 to 9999.

1) Cautions related to using data register (SW) and link register (SR) are applicable to 1-word data.

If the SW and the SR are used, be sure to use values in the range from -9999 to 9999. Data must be displayed in four digits (decimal notation).

Differences in displayed values between SW, SR and W, R

Data in the PLC	SW, SR	W, R
9999	9999	9999
1001	1001	1001
1000	1000	1000
999	999	999
0	0	0
-1	-1	32769
-999	-999	33767
-1000	-1000	33768
-1001	-1001	33769
-9999	-9999	42767

(Continued on next page)

- 2) *Cautions related to using a register applicable for 2-word data.
Using data register (DW) and link register (DR)*

If the DW and the DR are used, be sure to use values in the range from -9999 to 9999. Data must be displayed in four digits (decimal notation).

Differences in displayed values between DW, DR and W, R (2-word)

Data in the PLC	DW, DR	W, R
99999999	99999999	655304463
10000001	10000001	65536001
10000000	10000000	65536000
99999999	99999999	65535999
10000	10000	65536
9999	9999	9999
0	0	0
-1	-1	2147483649
-9999	-9999	2147493647
-10000	-10000	2147549184
-10001	-10001	2147549185
-99999999	-99999999	2212955111

■ CP-9200SH / MP900 /MP2300 Series

Setup System Area here.

Device	GP Device Address	CP-9200SH Device	Amount	Particulars	
Coil (bit device)	GMB00000 ~ GMB0624E	MB000000 + OFFSET to MB00624E + OFFSET	9999		
Coil (word device)	GMB0000 ~ GMB0624	MB00000 + OFFSET to MB00624 + OFFSET	625		*2
Input Relay (bit device)	GIB00000 ~ GIB0270E	IB00000 + OFFSET to IB0270E + OFFSET	9999		*1
Input Relay (word device)	GIB0000 ~ GIB0270	IB00000 + OFFSET to IB0270 + OFFSET	625		*1 *2
Hold Register (word device)	GMW0000 ~ GMW1023	MW00000 + OFFSET to MW01023 + OFFSET	1024	Bit F	L/H
	GMW1024 ~ GMW2047	MW01024 + OFFSET to MW02047 + OFFSET	1024	Bit F	
	GMW2048 ~ GMW3071	MW02048 + OFFSET to MW03071 + OFFSET	1024	Bit F	
	GMW3072 ~ GMW4095	MW03072 + OFFSET to MW04095 + OFFSET	1024	Bit F	
	GMW4096 ~ GMW5119	MW04096 + OFFSET to MW05119 + OFFSET	1024	Bit F	
	GMW5120 ~ GMW6143	MW05120 + OFFSET to MW06143 + OFFSET	1024	Bit F	
	GMW6144 ~ GMW7167	MW06144 + OFFSET to MW07167 + OFFSET	1024	Bit F	
	GMW7168 ~ GMW8191	MW07168 + OFFSET to MW08191 + OFFSET	1024	Bit F	
	GMW8192 ~ GMW9215	MW08192 + OFFSET to MW09215 + OFFSET	1024	Bit F	
	GMW9216 ~ GMW9998	MW09216 + OFFSET to W09998 + OFFSET	783	Bit F	
Input Register (word device)	GIW0000 ~ GIW03FF	IW00000 + OFFSET to IW03FF + OFFSET	1024	Bit F	*1
	GIW0400 ~ GIW07FF	IW0400 + OFFSET to IW07FF + OFFSET	1024	Bit F	*1
	GIW0800 ~ GIW08FF	IW0800 + OFFSET to IW08FF + OFFSET	1024	Bit F	*1
	GIW0C00 ~ GIW0FFF	IW0C00 + OFFSET to IW0FFF + OFFSET	1024	Bit F	*1
	GIW1000 ~ GIW13FF	IW1000 + OFFSET to IW13FF + OFFSET	1024 *Device range "0000" indicates it is hexadecimal	Bit F	*1

*1 Can be read out from a GP, however cannot be written to a GP.

*2 Cannot be written in the last (16th) bit of this address.(i.e, GMB0624/GIB0270)



- Designate the LS area bit at the end of the Word Address, using from 0 to F.
- Since the CP-9200SH unit's protocol is applicable to a 1:n connection, it will differ from the MEMOCON-SC's protocol and internal method of representing devices. When you wish to modify the screen data from a MEMOCON-SC, you will need to reenter device data.
- The hold Register and Input Register device settings must be entered within each block. Any settings that extend into other blocks are not allowed.
(Example: You cannot enter a 20 word long setting, starting from GMW1010.)



When you are setting up parts and tags in GP-PRO/PB III, you can designate PLC's station numbers as you are inputting addresses. If you do not designate the station numbers, the number following the one you previously entered will be automatically selected. (The factory setting is "1".)

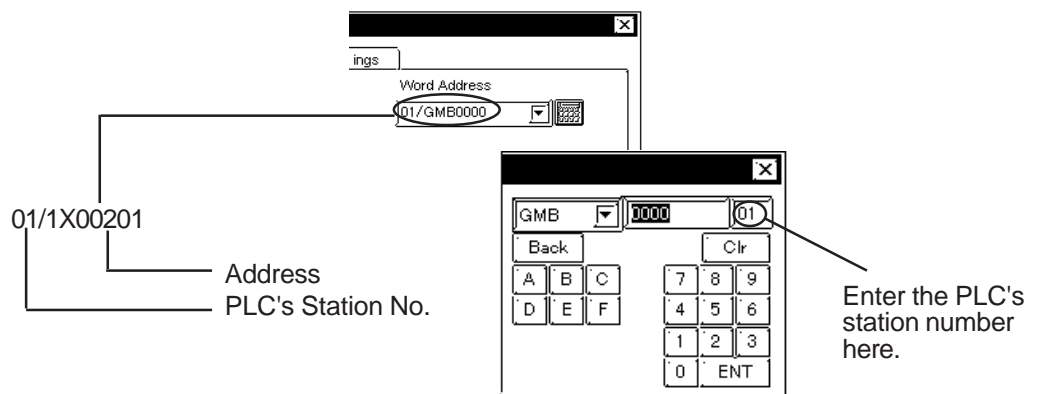

2.4.4 Environment Setup

The following lists Digital's recommended PLC and GP communication settings.

■ Memocon-SC Series

(GL40S/GL60S/GL60H/GL70H) (GL120CPU Direct Connection)

GP Setup		Communication Module Setup	
Baud Rate	19200 bps	Baud Rate	19200 bps
Data Length	8 bits (fixed)	Transfer Mode	RTU Mode (fixed)
Stop Bit	1 bit	Stop Bit	1 bit
Parity Bit	Even	Parity On/Off EVEN/ODD	ON EVEN
Data Flow Control	ER Control	---	
Communication Format	RS-232C	---	
---		Delay Count *1	0
Unit No.	1	Station Number Setting	1

■ Memocon-SC Series (U84/U84J/U84S)

GP Setup		Communication Module Setup	
Baud Rate	19200 bps	Baud Rate	19200 bps
Data Length	8 bits	Transfer Mode	RTU Mode
Stop Bit	1 bit	Stop Bit	1 bit
Parity Bit	Even	Parity Bit	EVEN
Data Flow Control	ER Control	---	
Communication Format	RS-232C	---	
---		Port Delay Timer	0
Unit No.	1	Address	1

■ Memocon-SC Series (GL120/GL130)

GP Setup		Communication Module Setup	
Baud Rate	19200 bps	Baud Rate	19200 bps
Data Length	8 bits		
Stop Bit	1 bit	Stop Bit	1 bit
Parity Bit	Even	ON/OFF	ON
Data Flow Control	ER Control	Even/ODD	Even
Communication Format	RS-422	Communicationsport	RS-422
---		Slave address No.	1
Unit No.	1	Communications bit	RTU mode (fixed)

* 1 There is no Delay Count for the JAMSC-IF60 SIO Module.

■ **PROGIC-8**

GP Setup		Port 1/Port 2 Setup	
Baud Rate (for Port 1 connection)	9600 bps (fixed)	---	
Baud Rate (for Port 2 connection)	19200 bps	Baud Rate (for Port 2 connection)	19200 bps
Data Length	8 bits	---	
Stop Bit	1 bit	---	
Parity Bit	Even	---	
Data Flow Control	ER Control	---	
Communication Format	RS-232C	---	
Unit No.	1	---	

■ **Control Pack Series**

GP Setup		Machine Controller 4CN/6CN Setup	
Baud Rate	9600 bps	Baud Rate	9600 bps
Data Length	8 bits	Data Bit	8 bits
Stop Bit	1 bit	Stop Bit	1 bit
Parity Bit	Even	Parity Bit	Even
Data Flow Control	ER Control	---	
Communication Format	RS-232C	---	
Unit No.	1	Station Number Setting	1

■ **Memocon Micro**

GP Setup		Comm1 Port Setup	
Baud Rate	9600 bps	Baud Rate	9600 bps
Data Length	8 bits	Data Bit	8 bits
Stop Bit	1 bit	Stop Bit	1 bit
Parity Bit	Even	Parity Bit	Even
Data Flow Control	ER Control	---	
Communication Format	RS-232C	---	
Unit No.	1	Station Number Setting	1

■ Control Pack Series for CP-9200SH

	GP Setup	PLC Setup
Baud rate	9600bps	9600bps
Data Length	8	8
Stop Bit	1	1
Parity Bit	Even	Even
Data Flow Control	ER Control	ER Control
Communication Format (RS-232C)	RS-232C	CN1 or CN2
(RS-422)	4 Wire-Type	CN3
System Area Start Address	GMW0000	-----
Station No.	1 ~ 32	1 ~ 32



- When connecting the GP77R Series unit to the "*****-21700-*****" or older version of 217IF unit, select the "GP Settings" menu's "Communication Settings" tab in 3.0 or later version of GP-PRO/PB III for Windows screen creation software, and click on the "Advanced" field, and then designate "20ms" for the "Send Wait" setting.
- A ladder program is needed when connecting the GP to a Yaskawa CP-217IF link I/F unit.
- Be aware that this sample program enables the GP to communicate with only one CN unit, and when you wish to use more than one CN unit (CN1 to CN3) at the same time you will need to create a ladder program for each CN.
- The PLC's communication settings cannot be entered by this program. You will need to enter these settings via the ladder software.

■ Control Pack Series CP-9200SH Sample program

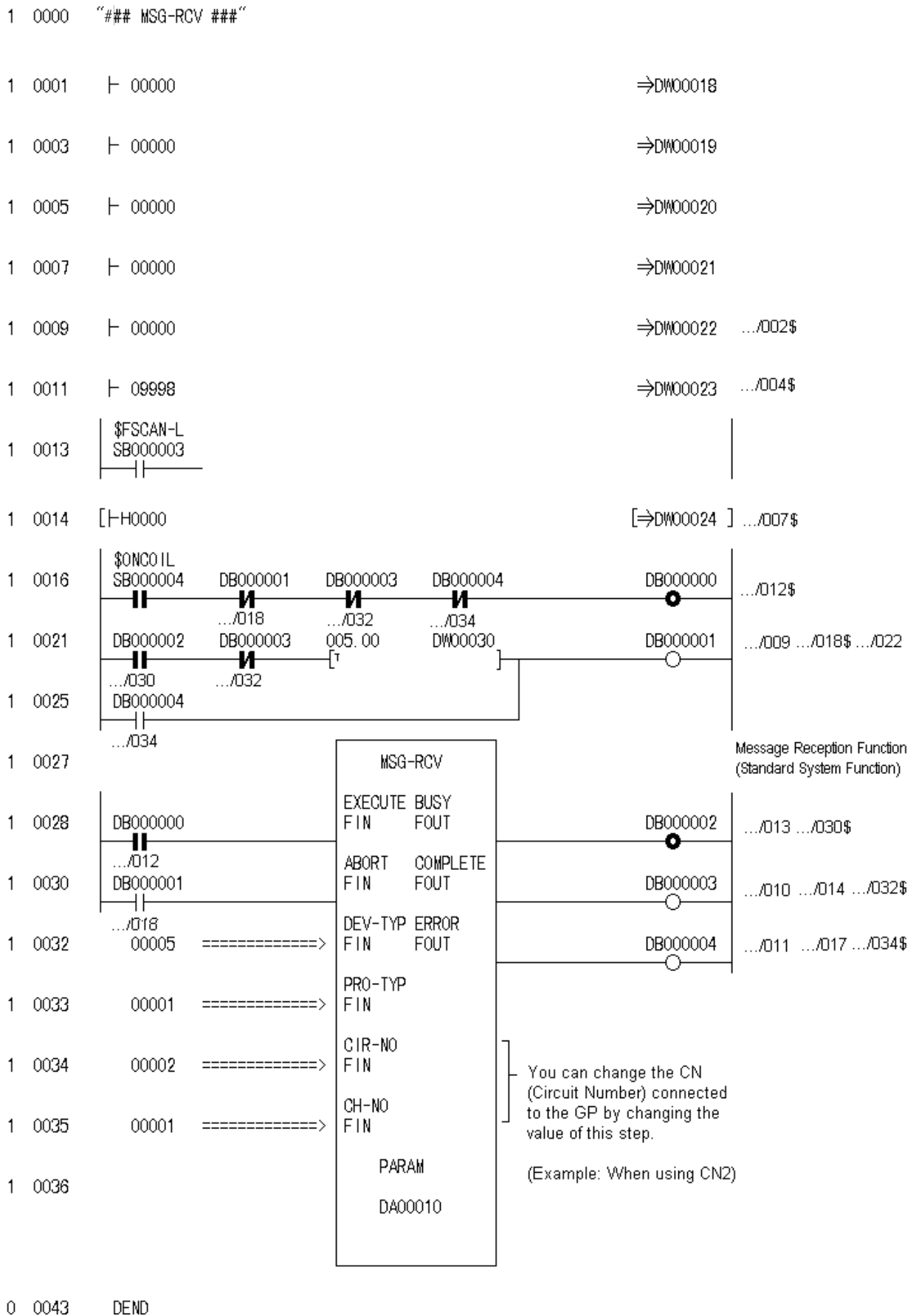

0 0043 DEND

■ MP900 Series

GP Setup		PLC Setup	
Baud rate	19200bps	Baud rate	19.2Kbps
Data Length	8	Data Length	8
Stop Bit	1	Stop Bit	1
Parity Bit	Even	Parity Bit	Even
Data Flow Control	ER Control	Send Mode	RTU
Communication Format (RS-232C)	RS-232C	Serial I/F (RS-232C)	RS-232C
Communication Format (RS-422)	4 Wire-Type	Serial I/F (RS-422)	RS-485
Unit No.	1	Device Address	01
	——	Master Slave	Slave
	——	Transmission Protocol	MEMOBUS



- A ladder program is needed when connecting the GP Series unit to a Yaskawa Electric corporation CP-217IF link I/F unit's CN1,CN2,CN3 or to MEMOBUS Ports (Port 1 or Port 2).
- Be aware that this sample program enables the GP to communicate with only one CN unit, and when you wish to use more than one CN unit at the same time you will need to create a ladder program for each CN.
- The PLC's communication settings cannot be entered by this program. You will need to enter these settings via the ladder software.

■ MP900 Series Sample program

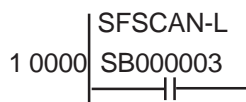

1 0001 IFON

2 0002 |-----| 00000

2 0004 |-----| 00000

2 0006 |-----| 00000

2 0008 |-----| 00000

2 0010 |-----| 00000

2 0012 |-----| 32787

2 0014 |-----| 00000

2 0016

2 0017

1 0018 IEND

Executed once only, when the unit's power is turned on. (Initialize the message receive function parameters.)

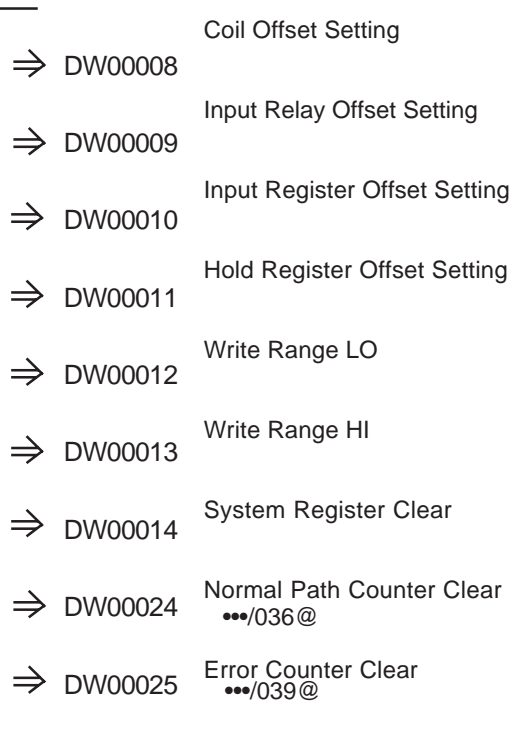

1 0019

1 0020 | SB000004

1 0022 | SB000004

1 0024 | 00005

1 0025 | 00001

1 0026 | 00001

1 0027 | 00001

1 0028

1 0035 | Normal Complete

DB000211

.../032

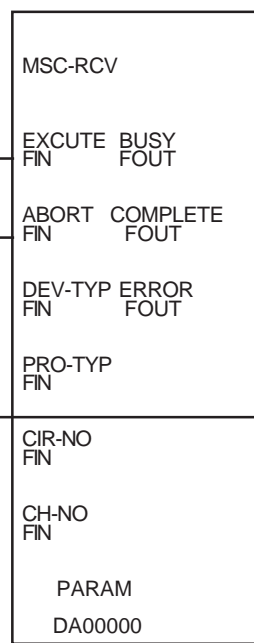

Message Reception Function (Standard System Function)

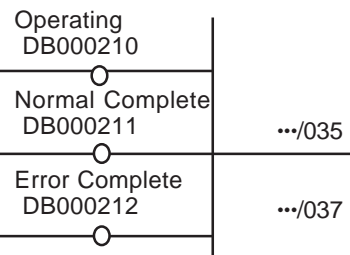

Enter 8 to Port 1 and Port 2 with the MP930CPU.
Enter 5 when using CN1, CN2 or CN3 with the CP-217IF.

Enter the GP or CN's Port No.

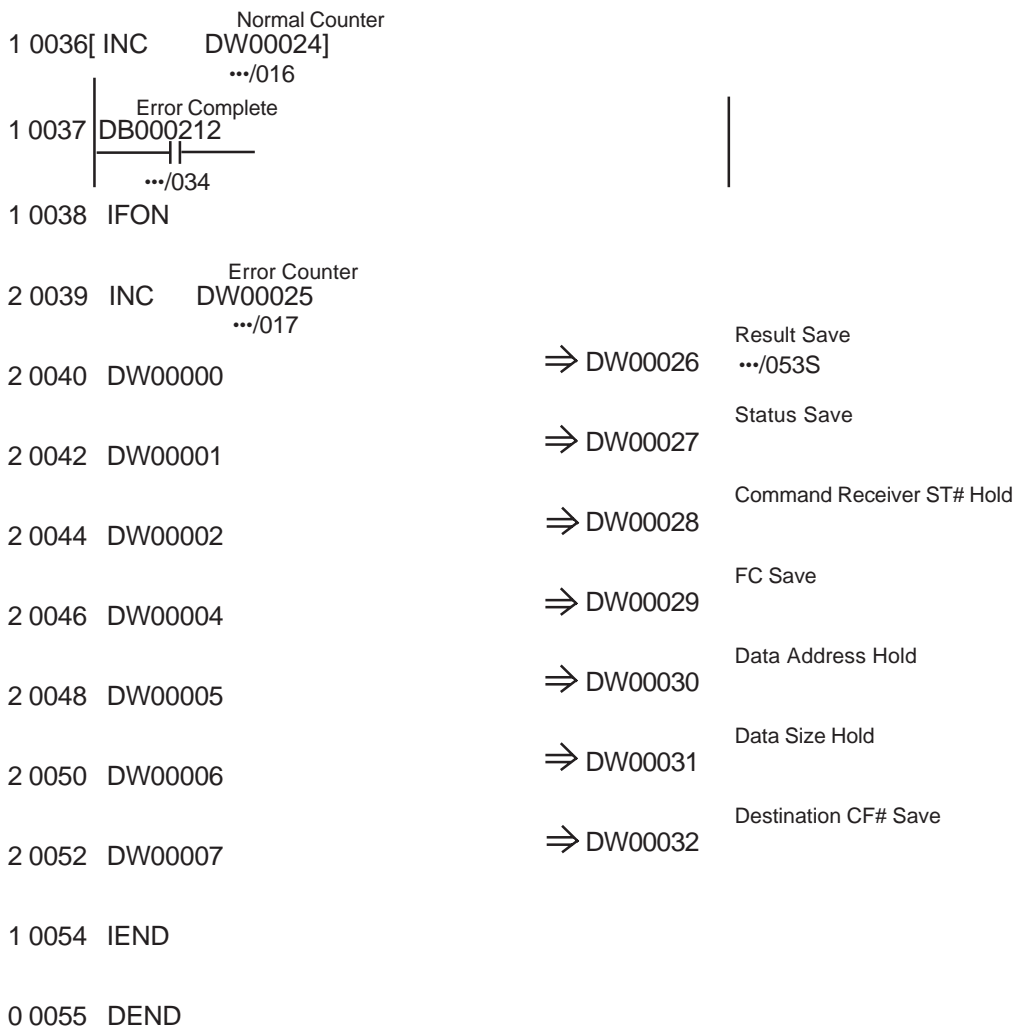

■ MP2300 Series

GP Setup		PLC Setup	
Transmission rate	19200bps	Baud rate	19200bps
Data Length	8	Data Length	8
Stop Bit	1	Stop Bit	1
Parity Bit	Even	Parity Bit	Even
Data Flow Control	ER Control	---	---
Communication Format	RS-232C	Serial I/F	RS-232C
	RS-422(4 Wire-Type)		RS-422/485
Unit No.	1 to 32	Device Address	1 to 32
---	---	Transmission Protocol	MEMOBUS
---	---	Master/Slave	Slave
---	---	Transmission Mode	RTU
---	---	Send Delay	Undesignated
---	---	Automatic Receive	Designated