

## Preface

The PSS-CD01 (CD-ROM Drive Unit) is designed for use with Pro-face's Compact Panel Computer PS-3701A (Eden™ ESP6000 - 667MHz Model), hereafter referred to as the "PS-A" and Panel Computer PL-X920/X930 Series, hereafter referred to as the "PL". While the PSS-CD01 provides a convenient way to install software into the PS-A/PL's HDD unit, it is not designed to be used outside of the development environment.

Corresponding Products: PS-3701A (Eden™ ESP6000 - 667MHz Model), and PL-X920/X930 Series units.

Pro-face is a trademark of Digital Electronics Corporation, registered in Japan and other countries. All other trademarks/registered trademarks are the properties of their respective owners.



### Warning - Safety Precautions

- Be sure to check that the PS-A/PL unit's power cord is disconnected before installing this unit. Failure to do so may cause an electric shock.
- Do not attempt to modify or open the PSS-CD01. This may cause a fire or an electric shock.
- Be sure to read the "2. Installation to PS-A" section or "3. Installation to PL" section completely to insure that the PSS-CD01 is correctly installed.

#### To Prevent Accidents

- Since the PSS-CD01 is a precision instrument, be sure it is neither hit by nor pressed strongly against another object.
- Be sure water, liquids or metal particles are not allowed to enter the PSS-CD01's connector. Any of these may cause either a breakdown or an electric shock.
- Do not store or operate this unit in a location where there is direct sunlight, excessive heat, dust or vibration.
- Do not store or operate the PSS-CD01 near chemicals, or where there are chemical fumes.
- Do not use the PSS-CD01 in locations where corrosive gases are present.
- To prevent damage to file data, be sure to shut down the PS-A/PL unit's OS before turning OFF the main power.

#### Unit Disposal

- When the product is disposed of, it should be done so according to your country's regulations for similar types of industrial waste.

# Package Contents

■ PSS-CD01 Unit (1)

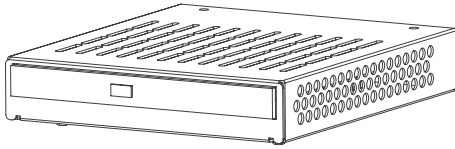

■ Connection Cable (1)

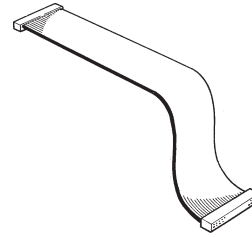

■ Front Face Fastener for PS-A (1)

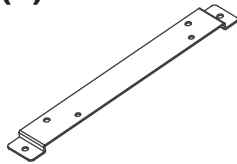

■ Rear Face Fastener for PS-A (1)

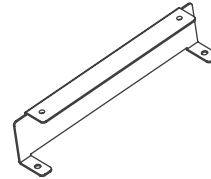

■ Front Face Fastener for PL (1)

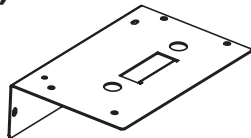

■ Rear Face Fastener for PL (1)

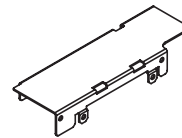

■ Attachment Screws (8)

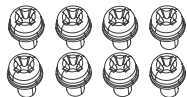

■ Installation Guide (1)

<This Guide>

Pro-face has taken utmost care to insure the quality of this product when it was shipped. However, for any reason, should you find any defects or damage, please contact your Pro-face representative immediately for service.

## 1 Hardware Specifications

■ Functional Specifications

Random Access Seek	115ms (Ave.)
Data Transfer Speed	16.7MB/s (Max.)
Disk Speed	5,136 rpm (typ)
Interface	IDE (ATAPI) <sup>*1</sup>
Power Consumption	During Startup: 1.0A (typ)
	During Random Access: 0.85A (typ)
	During Wait: 0.45A (typ)

\*1 The PSS-CD01's connection cable is a special-purpose cable. Any other type of cable cannot be used to connect this unit to the PS-A/PL unit.

## ■ Environmental Specifications

Surrounding Air Temperature	+5 °C to +50°C
Storage Temperature	-10°C to +60°C
Ambient Humidity	10%RH to 80%RH (no condensation)
Vibration Resistance	(during operation) 2.9m/s <sup>2</sup> (10Hz to 25Hz)
Shock Resistance	(not operating) 588m/s <sup>2</sup>

## 2 Installation to PS-A

Be sure to use the following installation procedures to ensure that the PSS-CD01 is correctly installed to PS-A.



### WARNINGS

**Shock Danger! Be sure to unplug the PS-A unit from its power supply prior to installing the PSS-CD01.**



**Note:** When using the PSS-CD01 with the PS-A unit, be sure to change the "IDE Primary Master PIO" and "IDE Primary Slave PIO" settings within the System Information area "INTEGRATED PERIPHERALS" to "Mode 2". Also, be sure to set the "IDE Primary Master UDMA" and "IDE Primary Slave UDMA" settings to "Disabled".

**Reference** *Compact Panel Computer PS-3701A(Eden™ ESP6000 - 667MHz Model) User Manual, Chapter 3 System Setup.*

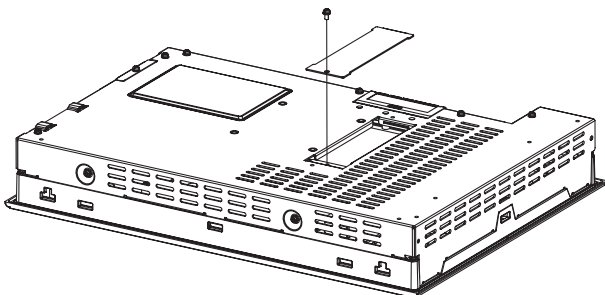

- 1) Unscrew the CD-ROM Drive I/F cover's two (2) attachment screws. Remove the CD-ROM Drive I/F cover.

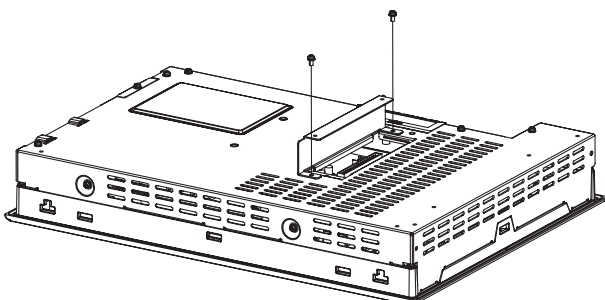

- 2) Secure the rear face fastener to the rear of the PS-A unit using the two (2) attachment screws. The torque should be 0.5 to 0.6N•m.

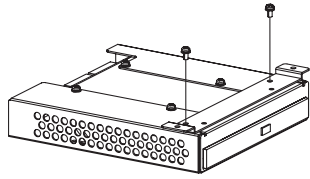

- Secure the front face fastener to the PSS-CD01 using the two (2) attachment screws. The torque should be 0.5 to 0.6N•m.

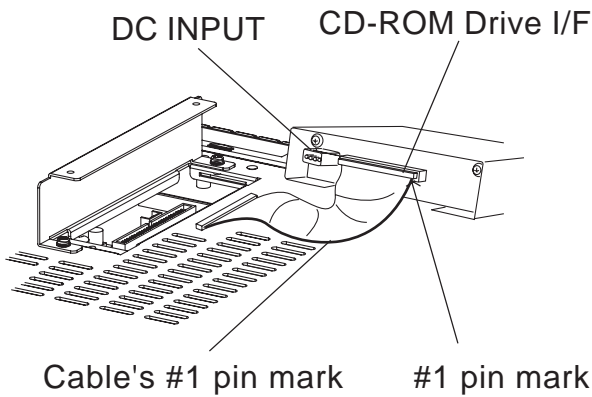

- Connect the PSS-CD01 to the PS-A unit via the connection cable. Be sure to confirm that the Cable's #1 pin mark and the connector are correctly aligned.



• **Do not connect anything to the DC INPUT Connector.**

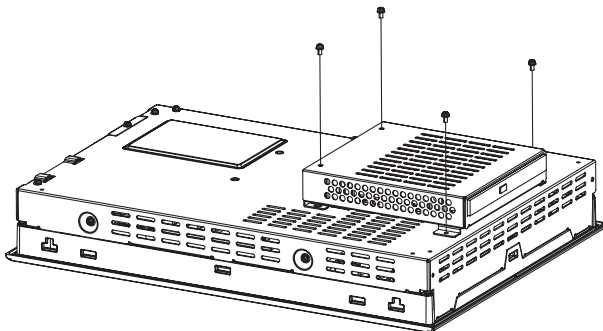

- Secure the PSS-CD01 to the PS-A unit using the four (4) attachment screws. The torque should be 0.5 to 0.6N•m. Place the cable in the opening between the PSS-CD01 and PS-A units.



### Caution

Refer to the following drawings to confirm that the connection cable is securely attached to both connectors. Be sure to check both connectors before turning the PS-A ON, since incorrect attachment of the connectors can cause equipment damage.

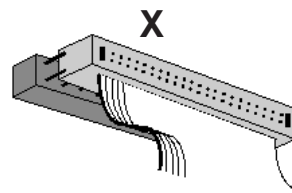
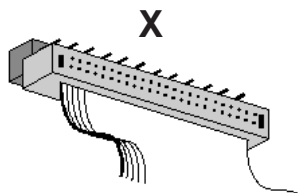

### 3 Installation to PL



- When the PSS-CD01 unit is used with PL-X920 Series, the Slave HDD cannot be used. Be sure to uninstall(remove) the Slave HDD unit.
- For PL-X930 Series, if you want to use the HDD/CF card unit in the "Expansion Slot 1" together with the CD-ROM drive unit, the setting of the HDD/CF card unit must be "Master" (as the first disk). To do failure so, it may cause malfunction.



## WARNINGS

**Shock Danger! Be sure to unplug the PL unit from its power supply prior to installing the PSS-CD01.**



When using the CD-ROM drive unit with the PL-X920 Series unit, be sure to change the "IDE Primary Master PIO" and "IDE Primary Slave PIO" settings within the "System Information area INTEGRATED PERIPHERALS" to "Mode 2". Also, be sure to set the "IDE Primary Master UDMA" and "IDE Primary Slave UDMA" settings to "Disabled".

**Reference** *PL Series User Manual, Chapter 5 System Setup.*

#### ■ PL-X920/X930 Series (4-slot type)

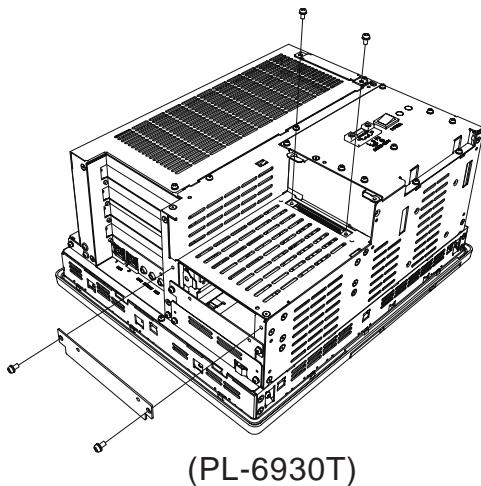

(PL-6930T)

- 1) Unscrew the IDE cover's two (2) attachment screws. Remove the IDE cover.
- 2) Unscrew the Expansion Slot 1 cover's two (2) attachment screws. Remove the the cover.

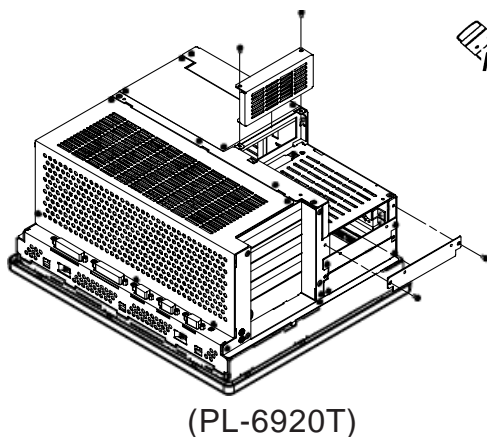

(PL-6920T)



- IDE Cover for PL-X920 Series is as shown left. Remove the IDE Cover as same as PL-X930 Series.

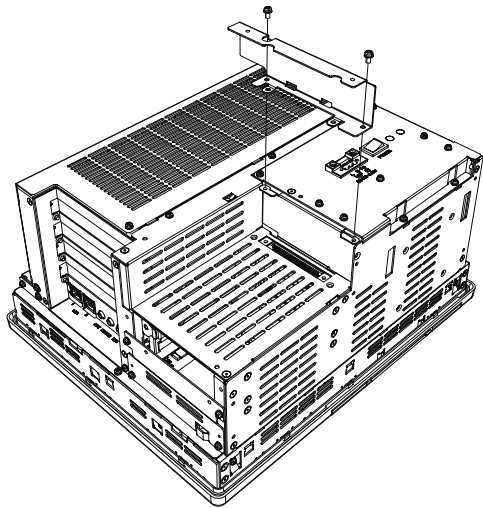

- Secure PL rear face fastener to the rear of the PL unit using the two (2) attachment screws. Fastening torque should be 0.5 to 0.6N•m.

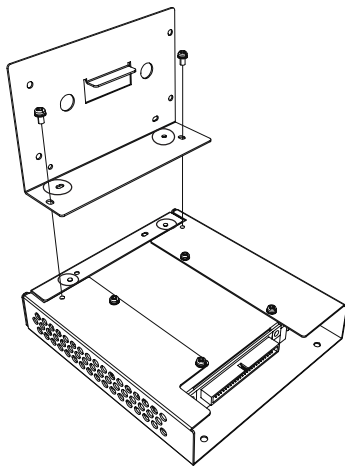

- Secure PL front face fastener to the bottom of the PSS-CD01 unit using the two (2) attachment screws. Fastening torque should be 0.5 to 0.6N•m.



**Note:** • Insert firmly both sides of parts, which are marked with thick circles (salients and holes) .

Cable's #1 pin mark

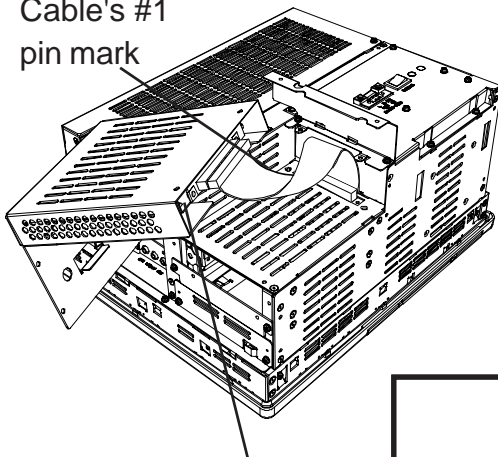

DC INPUT Connector

- Connect the CD unit to the PL unit via the connection cable, folded the cable over, along the diagonal line. Be sure to confirm that the Cable's #1 pin mark and the connector are correctly aligned.



• **Do not connect anything to the DC INPUT Connector.**



### Caution

Refer to the following drawings to confirm that the connection cable is securely attached to both connectors. Be sure to check both connectors before turning the PL ON, since incorrect attachment of the connectors can cause equipment damage.

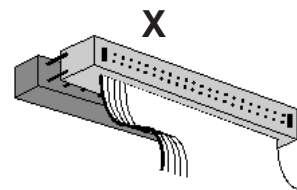
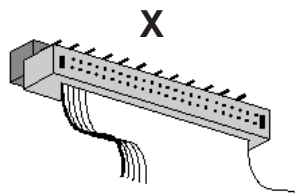

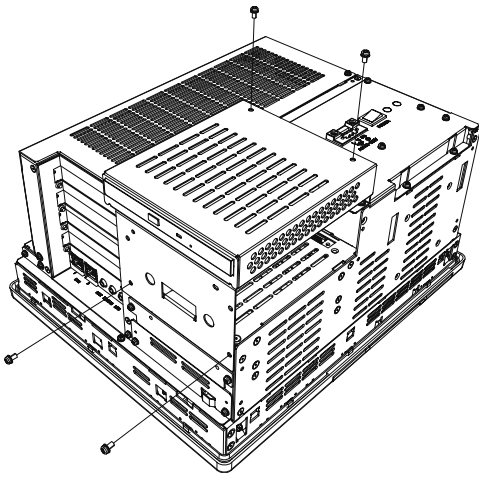

- 6) Secure the PSS-CD01 to the PL unit using the four (4) attachment screws. The torque should be 0.5 to 0.6N•m. Place the cable in the opening between the PSS-CD01 and PL units.



- **When using the HDD/CF Card unit within the Expansion Slot 1 for PL-X930 Series, Step 6) is not required. PSS-CD01 should be used, unattached on the rear of PL unit.**

### ■ PL-X921/X931 Series (2-slot type)

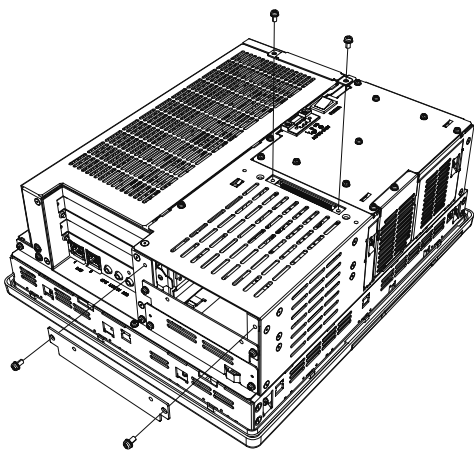

(PL-6931 Series)

- 1) Unscrew the IDE cover's two (2) attachment screws. Remove the IDE cover.
- 2) Unscrew the Expansion Slot 1 cover's two (2) attachment screws. Remove the the cover.

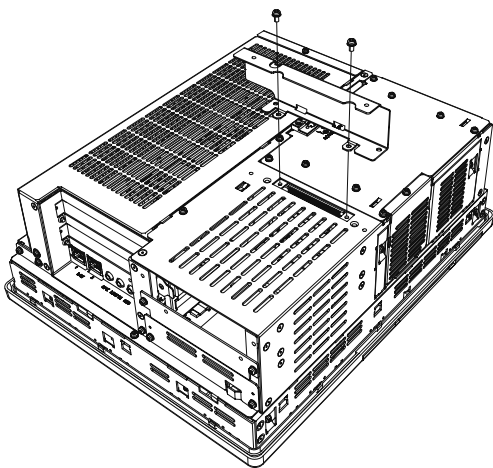

- 3) Secure PL rear face fastener to the rear of the PL unit using the two (2) attachment screws. Fastening torque should be 0.5 to 0.6N•m.

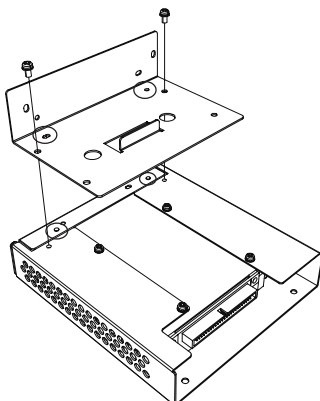

- 4) Secure PL front face fastener to the bottom of the PSS-CD01 unit using the two (2) attachment screws. Fastening torque should be 0.5 to 0.6N•m.



- Insert firmly both sides of parts, which are marked with thick circles (salients and holes) .

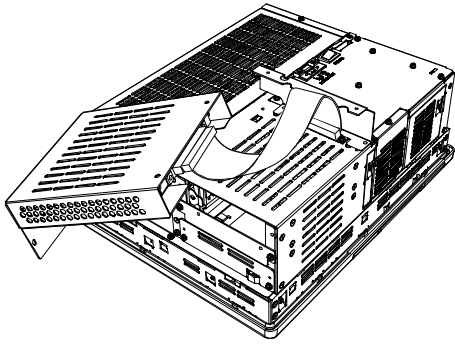

- 5) Connect the CD unit to the PL unit via the connection cable, folded the cable over, along the diagonal line. Be sure to confirm that the Cable's #1 pin mark and the connector are correctly aligned.



- **Do not connect anything to the DC INPUT Connector.**



### Caution

Refer to the following drawings to confirm that the connection cable is securely attached to both connectors. Be sure to check both connectors before turning the PL ON, since incorrect attachment of the connectors can cause equipment damage.

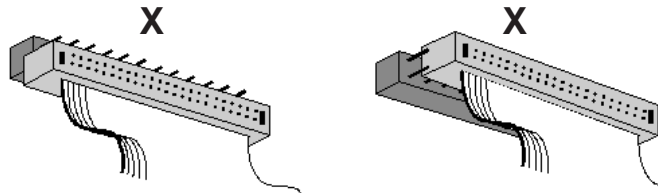

- 6) Secure the PSS-CD01 to the PL unit using the four (4) attachment screws. The torque should be 0.5 to 0.6N•m. Place the cable in the opening between the PSS-CD01 and PL units.

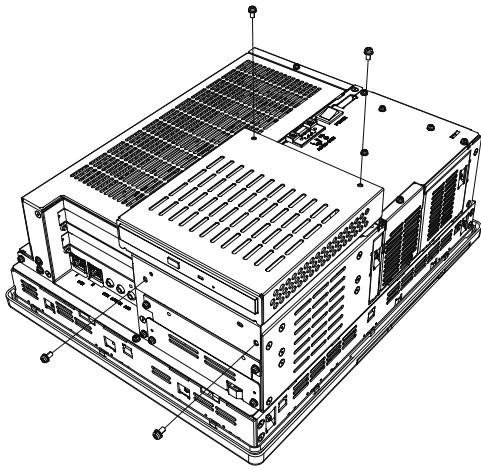

- **When using the HDD/CF Card unit within the Expansion Slot 1 for PL-X931 Series, Step 6) is not required. PSS-CD01 should be used, unattached on the rear of PL unit.**

### Note

Please be aware that Digital Electronics Corporation shall not be held liable by the user for any damages, losses, or third party claims arising from the uses of this product.

Digital Electronics Corporation

8-2-52 Nanko Higashi, Suminoe-ku, Osaka 559-0031, Japan

URL: <http://www.pro-face.com/>

© 2003 Digital Electronics Corporation All rights reserved.