

PL-RC500

Installation Guide

The PL-RC500 is an RS-232C/RS-485 conversion unit that is designed for use with Pro-face's Panel Computer (hereafter referred to as the "PL") units, Compact Panel Computer (hereafter referred to as the "PS-A") units, and Built-in Computer PS-2000B Series (hereafter referred as the "PS-B") units. This unit connects to the PL/PS-A/PS-B's RS-232C interface, and converts this interface to an RS-485 interface.

Compatible models: PL-5900/PL-5910/PL-X920/PL-X930/PS-3650A/PS-2000B Series

All product names used in this document are the trademarks of their respective manufacturers.



WARNINGS

- Be sure to check that the PL/PS-A/PS-B unit's power is disconnected before installing the PL-RC500 in the PL/PS-A/PS-B in order to prevent electrical shock.
- Do not attempt to modify or open the PL-RC500, due to the danger of breakdown, shock, or fire.
- Prior to starting PL-RC500 installation, be sure to read this manual's "4. Installation" carefully for correct installation.

To Prevent Accidents

- Since the PL-RC500 is a precision instrument, be sure it is neither hit by nor pressed strongly against another object.
- Be sure water, liquids or metal particles are not allowed to enter the unit. Any of these may cause either a breakdown or an electrical shock.
- Do not place or store this unit in a location where there is direct sunlight, excessive heat, dust or vibration.
- Do not store or operate this unit near chemicals, or where there are chemical fumes.
- Do not store or operate this unit in a location where corrosive gases can be generated.

Unit Disposal

- When this product is disposed of, it should be done so according to your country's regulations for similar types of industrial wastes.

Package Contents

■ PL-RC500 Conversion Unit

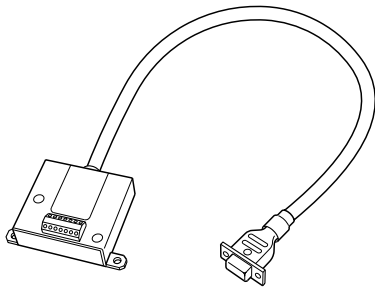

■ Installation Guide

(PL-RC500)
(English and Japanese)

■ PS-A/PS-B Attachment Screws (2)



Pro-face has taken the utmost care to insure the quality of this product when it was shipped, however, should, for any reason, problems or damage have occurred during shipping, please contact your Pro-face representative immediately for service.

1 Hardware Specifications

■ Structural Specifications (mm[in.])

External Dimensions	W58[2.28] ×H55[2.17] ×D17[0.67]
Weight	approx. 120g
Cable Length	400[15.75]

2 Interface Specifications

■ RS-485 (Communication Standard: TIA/EIA-485<115.2Kbps>)



- *The PL-RC500's RS-485 port is not isolated. If this cable is connected to an external device that is also not isolated, be sure to connect the SG terminal to prevent RS-485 circuit damage.*
- *The GND line is the signal ground. Connect the PL/PS-B unit's SG terminal to the SG (Signal Ground) terminal of the external device. Depending on the external device used, the FG terminal should be connected only when necessary.*

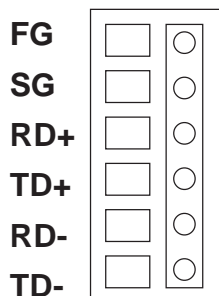

Signal Name	Meaning
FG	Frame Ground
SG	Signal Ground
RD+	Data Receive (+)
TD+	Data Send (+)
RD-	Data Receive (-)
TD-	Data Send (-)

< I/F Circuit >

SN751178N(Equivalent Device)

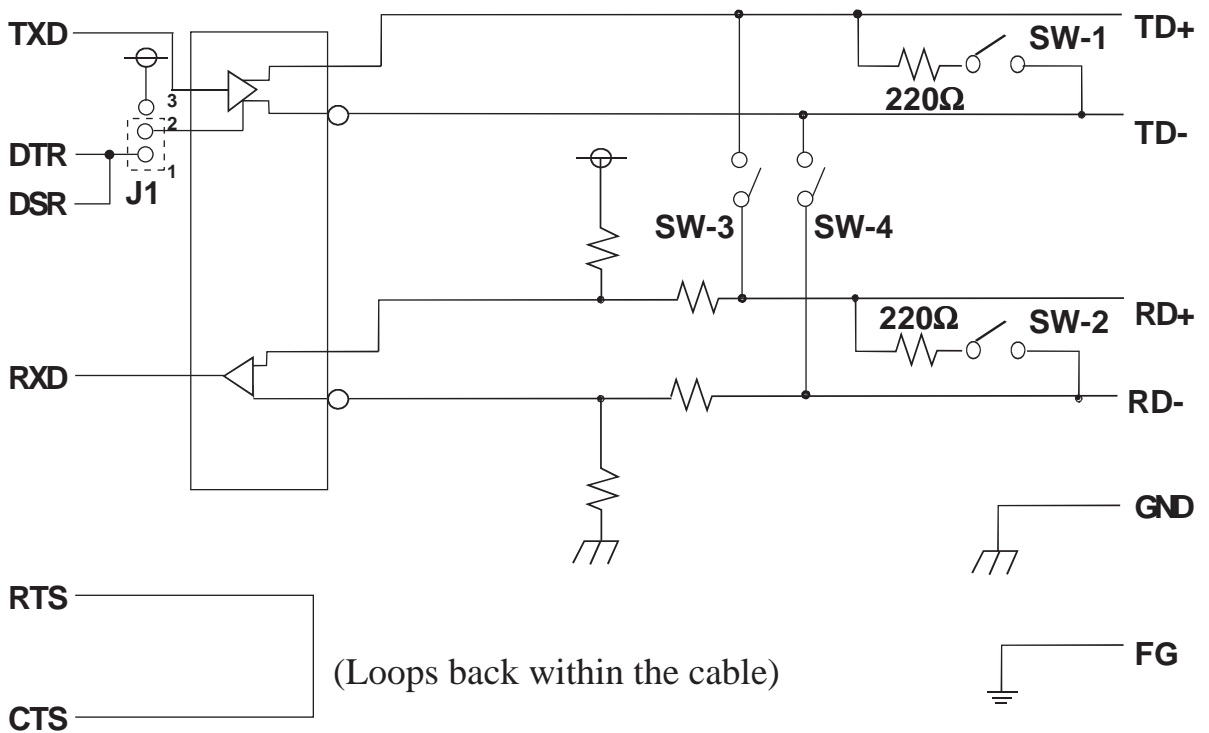

J1  is the factory settings.

Depending on the device used, connect the GND, FG only when necessary.

■ RS-232C

Dsub 9-pin (female)

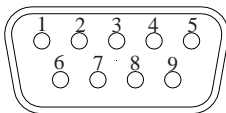

Screw size: (4-40): Inch type

Pin No.	Signal Name	
1	DCD	NC
2	TXD	Input
3	RXD	Output
4	DTR	Input
5	GND	—
6	DSR	Output
7	CTS	Output
8	RTS	Input
9	+5V	—

The above signal names match the PL/PS-A/PS-B unit's signal names.



The PL-RC500 must control the communication (send) buffer using DTR. (Refer to the previous page's circuit drawing.) When sending data from the PL-RC500, be sure to use your application to turn the DTR signal ON.

When you will not use your application for DTR control, short the J1 jumper between pins 2 and 3 (factory setting is shorted between pins 1 and 2), and change the DTR signal to normally ON. For example, earlier versions of Pro-Designer (up to Ver. 3.1) did not perform DTR control. As a result the DTR signal must be set to normally ON when using this software. This also will require that the connection type is limited to 1:1 connections.

3 Cable Communication Settings

This cable's connector has dip switches on its rear face. These dip switches are used to insert termination resistance and perform loopback, thereby eliminating the need to physically modify the cable.

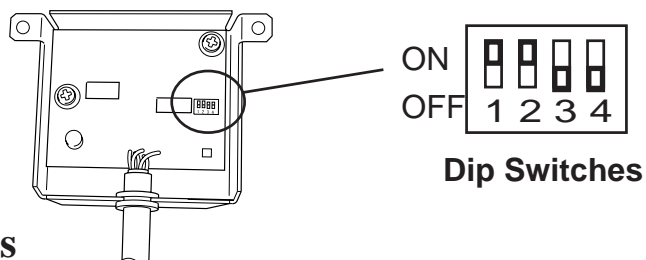

■ Dip Switch Settings

SW No.	Factory Settings	Meaning
SW-1	ON	If set to ON, inserts 220Ω of resistance between TD+ and TD-.
SW-2	ON	If set to ON, inserts 220Ω of resistance between RD+ and RD-.
SW-3	OFF	If set to ON, provides loopback between TD+ and RD+.
SW-4	OFF	If set to ON, provides loopback between TD- and RD-.

■ 2-wire Settings

Set dip switches SW-1 and SW-2 to OFF, and set SW-3 and SW-4 to ON. Then, use the following schematic to create a loop between TD and RD. Also, use the wiring diagram to insert 110Ω of termination resistance between TD+ and TD-.

Wiring Drawing

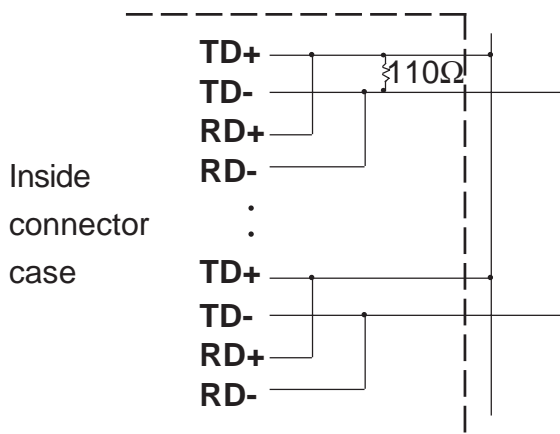

- If you wish to wire your cable using settings that are different from those given here, be sure those settings match your system's actual specifications.
- Including this unit, a maximum of 32 units can be connected, up to a distance of 1.2km.
- Be sure the termination resistance set up matches your system's actual connection specifications.

■ 4-wire Settings

Set dip switches SW-3 and SW-4 to OFF, and use the wiring diagram below to remove the loop between TD and RD. If you wish to insert termination resistance, set SW-1 and SW-2 to ON. This will insert 220Ω termination resistance between TD+ and TD-, and between RD+ and RD-.

Wiring Drawing

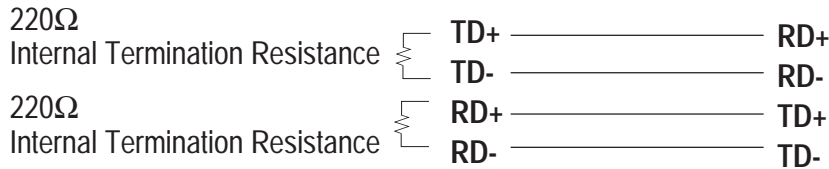

- If you wish to wire your cable using settings that are different from those given here, be sure those settings match your system's actual specifications.
- Including this unit, a maximum of 32 units can be connected, up to a distance of 1.2km.
- Be sure the termination resistance set up matches your system's actual connection specifications.

4 Installation

This unit is connected to an RS-232C interface. The following table shows the types of RS-232C connectors that can be used.

Model	RS-232C Connector
PL	COM2 or COM3
PS-A	COM1
PS-B	COM1 or COM3



If you wish to re-use your existing PL-5700 series RS-485 application on the PL-5900/PL-5910, be sure to connect the PL-RC500 to COM3.



WARNING

Shock Danger! Be sure to disconnect the PL/PS-A/PS-B unit's power cord prior to installing the PL-RC500.

Use the following procedure to install the PL-RC500 unit.



- *Do not pinch the PL-RC500 cable inside the PL/PS-A/PS-B, or press it against other devices.*
- *Do not pull or twist the PL-RC500 cable with excessive force.*

Installation the PL-RC500 on a PL unit

1. Set the RS-232C interface's signal to +5V.

With a PL-5900/PL-5910 Series Unit

Confirm that the RS-232C connector's +5V/RI signal change switch is set to +5V. (The factory setting is "RI".)

Signal Change Switch

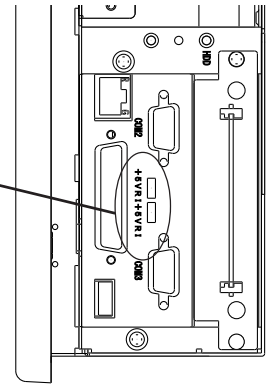

With a PL-X920 Series Unit

Remove the PL unit's rear maintenance cover. Then, set the rear face circuit board's Main Function Switch to ON. When the COM3 connector is selected, set the Main Function Switch (SW3) to ON. The same applies to COM2 (SW2).



Note: • For information about "Installing/Removing the Rear Maintenance Cover", refer to the PL unit's User Manual

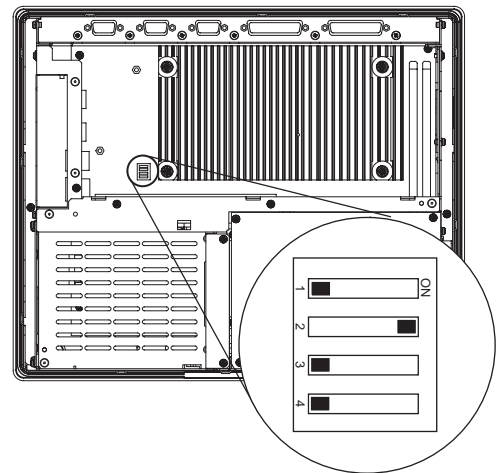

With a PL-X930 Series Unit

Remove the PL unit's rear maintenance cover. Then, set the circuit board's changeover switch (RI/+5V) to +5V. When the COM2 connector is selected, set the changeover switch (RI/+5V) for COM2 to +5V. The same applies to COM3. (The factory setting is "RI".)



Note: • For information about "Installing/Removing the Rear Maintenance Cover", refer to the PL unit's User Manual

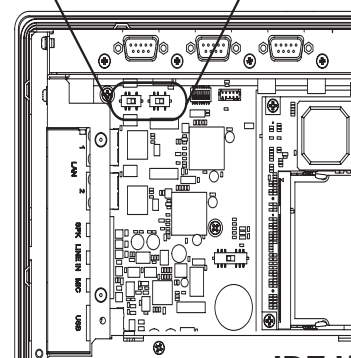
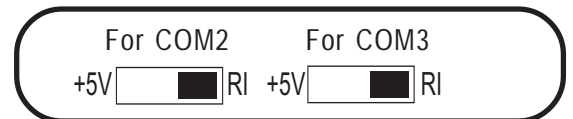

IDE I/F Cover

2. Remove the two (2) IDE I/F cover attachent screws and attach this cable's connector.

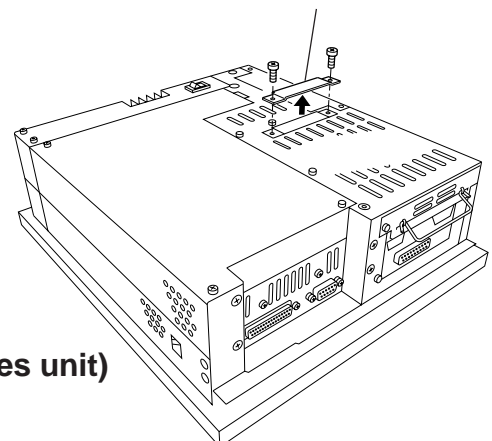

(PL-5900 Series unit)



- **If you have already attached the optional Mirror Disk unit to your PL, since the PL's IDE I/F cover is not available, simply remove the Mirror Disk unit's IDE I/F cover and attach this unit to it.**
- **When the PL-RC500 is used, the PL's optional CD-ROM drive unit cannot be used.**

3. Reattach the two (2) attachment screws removed in step 2.
4. Attach this cable's connector to the RS-232C interface (COM2 or COM3). Then, secure the connector in place with the connector's attachment screws.

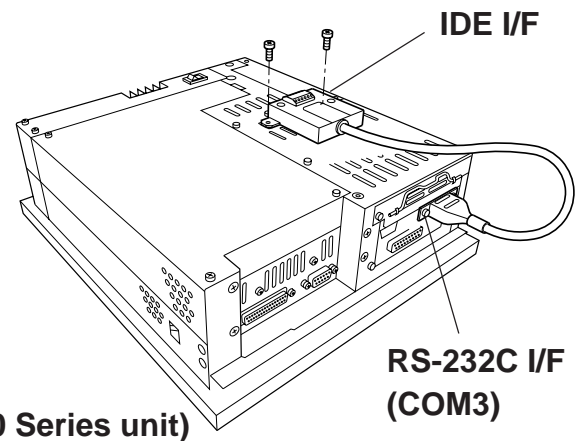

(PL-5900 Series unit)

Installation the PL-RC500 on a PS-A unit

Use the following steps to install the PL-RC500 in the PS-A. Even though the unit shown below is a PS-3650A Series unit, the PS-3651A Series installation procedures are the same.

1. Remove the PS-3650A Series unit's Fan Cover (Memory Slot Cover for PS-3651A Series). Then, set the circuit board's changeover switch (RI/+5V) to +5V. (The factory setting is "RI".)

Note: • For information about "Installing/Removing the Fan Cover (Memory Slot Cover)", refer to the PS-A unit's User Manual

2. Replace the PS-3650A unit's Fan Cover (Memory Slot Cover for PS-3651A Series), then, attach the PL-RC500 to the rear of the PS-A unit, using the two (2) attachment screws. (see diagram)
The torque should be 0.5 to 0.6 N•m.
3. Attach the RS-232C connector to the RS-232C interface (COM1). Then, secure the RS-232C connector in place with the connector's attachment screws.

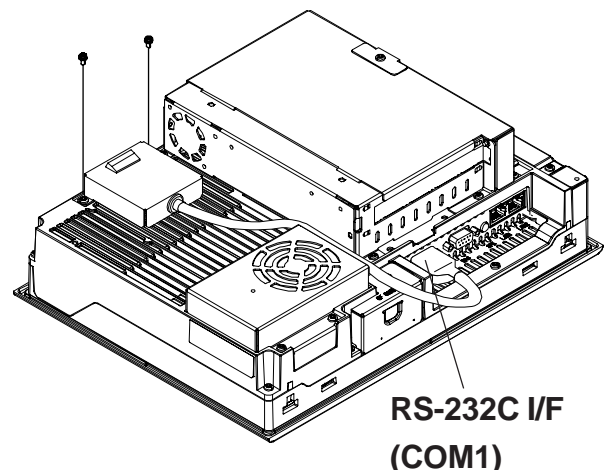
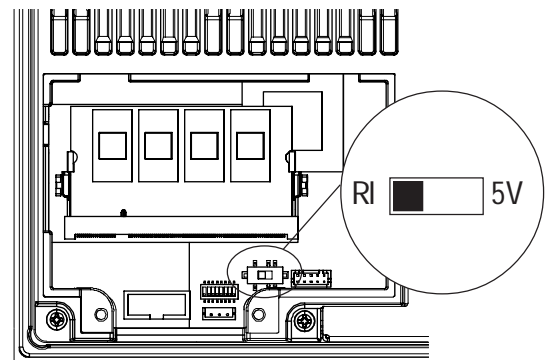

Installation the PL-RC500 on a PS-B unit

Even though the unit shown below is a PS-2000B Series 3 slots type unit, the PS-2000B Series 6 slots type unit installation procedures are the same.

1. Lay the PS-B unit on its side and unscrew the four (4) cover attachment screws.
2. Slide the cover horizontally in the direction shown by the arrow (see diagram) and lift it up from the PS-B unit.
3. Set the changeover switch (RI/+5V) for the main circuit board COM port that you will use (COM1 or COM3) to "+5V". (The factory setting is "RI".)

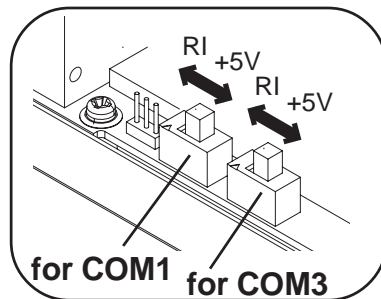

+5V/RI Signal Change Switch

4. Replace the PS-B unit's cover and reattach all four (4) attachment screws.

The torque should be 0.6 to 0.8 N•m.

5. Attach the PL-RC500 to the top of the PS-B unit's case, using the two (2) attachment screws. (see diagram)

The torque should be 0.5 to 0.6 N•m.

6. Attach the RS-232C connector to the RS-232C connector (COM1 or COM3). Then, secure the RS-232C connector in place with the connector's attachment screws.

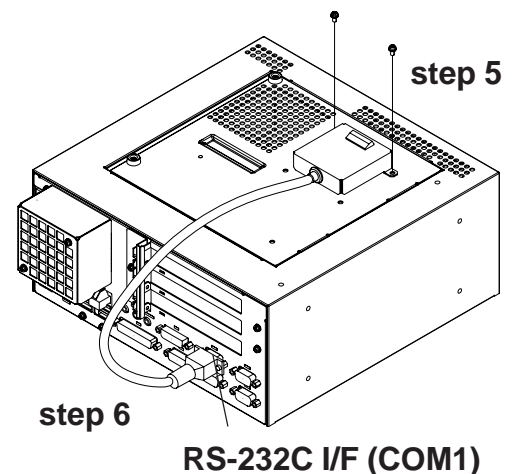
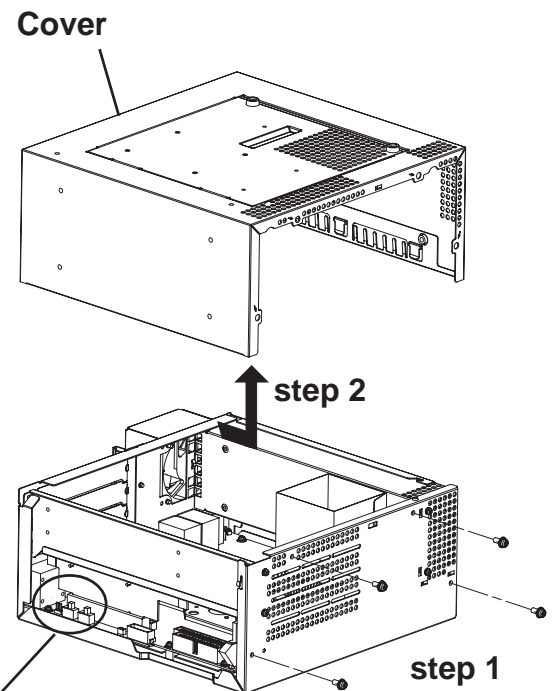

Note

Please be aware that Digital Electronics Corporation shall not be held liable by the user for any damages, losses, or third party claims arising from the uses of this product.

Digital Electronics Corporation

8-2-52 Nanko Higashi, Suminoe-ku, Osaka 559-0031, Japan

URL: <http://www.pro-face.com/>