



Series 90-30/70 SNP Driver

1	System Configuration.....	3
2	Selection of External Device	8
3	Example of Communication Setting.....	9
4	Setup Items	13
5	Cable Diagram	17
6	Supported Device.....	27
7	Device Code and Address Code.....	28
8	Error Messages	29

Introduction

This manual describes how to connect the Display and the External Device (target PLC).

In this manual, the connection procedure will be described by following the below sections:

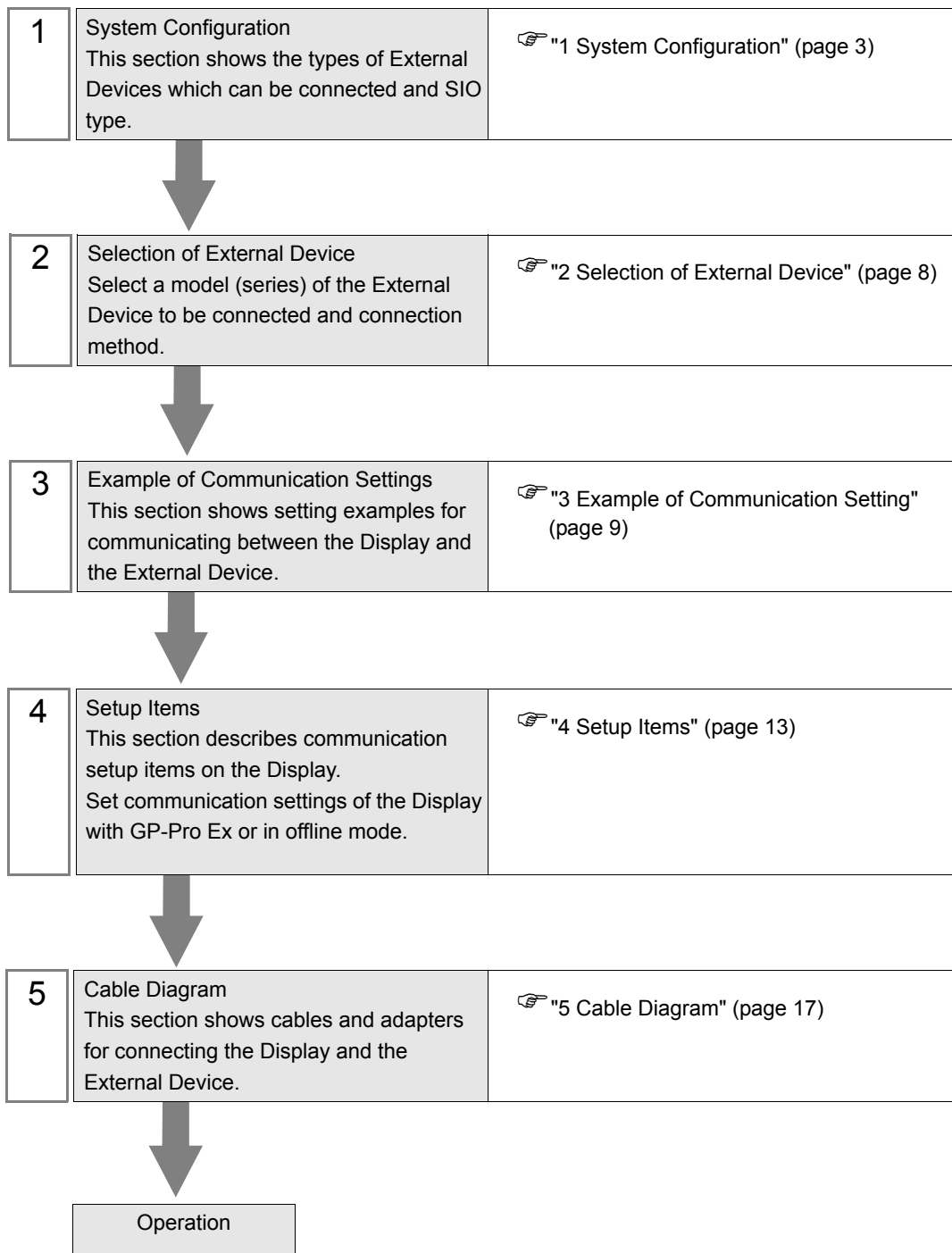

1 System Configuration

The system configuration in the case when the External Device of GE Intelligent Platforms and the Display are connected is shown.

Series	CPU	Link I/F	SIO Type	Setting Example	Cable Diagram
Series 90-30	IC693CPU311 IC693CPU313 IC693CPU321 IC693CPU323 IC693CPU331 IC693CPU340 IC693CPU341 IC693CPU350 IC693CPU351 IC693CPU352 IC693CPU360 IC693CPU363 IC693CPU364 IC693CPU374 IC693CSE311 IC693CSE313 IC693CSE323 IC693CSE331 IC693CSE340	SNP serial port on power supply unit	RS422/485 (4wire)	Setting Example 1 (page 9)	Cable Diagram 1 (page 17)
Series 90-70	IC697CPU731 IC697CPU771 IC697CPU772 IC697CPU780 IC697CPU781 IC697CPU782 IC697CPU788 IC697CPU789 IC697CPM790 IC697CPM915 IC697CPM925 IC697CPX722 IC697CPX782 IC697CPX928 IC697CPX935 IC697CGR772 IC697CGR935 IC697CSE784 IC697CSE924 IC697CSE925	SNP serial port on CPU	RS422/485 (4wire)	Setting Example 2 (page 11)	

NOTE • Do not use the logic function in the Display. If it is used, a communication error occurs.

■ Connection Configuration

Series 90-30: SNP Serial Port on the PLC power supply

Series 90-70: SNP Serial Port on the PLC CPU Unit

- 1:1 Connection



- 1:n Connection

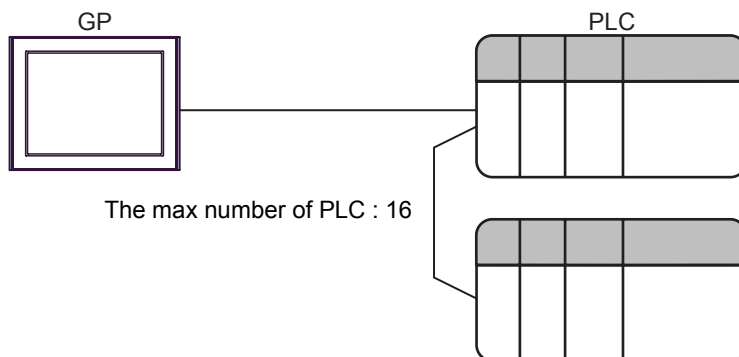

■ IPC COM Port

When connecting IPC with an External Device, the COM port used depends on the series and SIO type. Please refer to the IPC manual for details.

Usable port

Series	Usable Port		
	RS-232C	RS-422/485(4 wire)	RS-422/485(2 wire)
PS-2000B	COM1 ^{*1} , COM2, COM3 ^{*1} , COM4	-	-
PS-3450A, PS-3451A, PS3000-BA, PS3001-BD	COM1, COM2 ^{*1*2}	COM2 ^{*1*2}	COM2 ^{*1*2}
PS-3650A (T41 model), PS-3651A (T41 model)	COM1 ^{*1}	-	-
PS-3650A (T42 model), PS-3651A (T42 model)	COM1 ^{*1*2} , COM2	COM1 ^{*1*2}	COM1 ^{*1*2}
PS-3700A (Pentium®4-M) PS-3710A	COM1 ^{*1} , COM2 ^{*1} , COM3 ^{*2} , COM4	COM3 ^{*2}	COM3 ^{*2}
PS-3711A	COM1 ^{*1} , COM2 ^{*2}	COM2 ^{*2}	COM2 ^{*2}
PS4000 ^{*3}	COM1, COM2	-	-
PL3000	COM1 ^{*1*2} , COM2 ^{*1} , COM3, COM4	COM1 ^{*1*2}	COM1 ^{*1*2}
PE-4000B Atom N270	COM1, COM2	-	-
PE-4000B Atom N2600	COM1, COM2	COM3 ^{*4} , COM4 ^{*4} , COM5 ^{*4} , COM6 ^{*4}	COM3 ^{*4} , COM4 ^{*4} , COM5 ^{*4} , COM6 ^{*4}
PS5000 (Slim Panel Type Core i3 Model) ^{*5*6}	COM1, COM2 ^{*4}	COM2 ^{*4}	COM2 ^{*4}
PS5000 (Slim Panel Type Atom Model) ^{*5*6}	COM1, COM2 ^{*7}	COM2 ^{*7}	COM2 ^{*7}
PS5000 (Enclosed Panel Type) ^{*8}	COM1	-	-
PS5000 (Modular Type PFXPU/PFXPP) ^{*5*6} PS5000 (Modular Type PFXPL2B5-6)	COM1 ^{*7}	COM1 ^{*7}	COM1 ^{*7}
PS5000 (Modular Type PFXPL2B1-4)	COM1, COM2 ^{*7}	COM2 ^{*7}	COM2 ^{*7}

*1 The RI/5V can be switched. Use the IPC's switch to change if necessary.

*2 Set up the SIO type with the DIP Switch. Please set up as follows according to SIO type to be used.

*3 When making communication between an External Device and COM port on the Expansion slot, only RS-232C is supported. However, ER (DTR/CTS) control cannot be executed because of the specification of COM port.

For connection with External Device, use user-created cables and disable Pin Nos. 1, 4, 6 and 9. Please refer to the IPC manual for details of pin layout.

*4 Set up the SIO type with the BIOS. Please refer to the IPC manual for details of BIOS.

- *5 When setting up communication between an External Device and the RS-232C/422/485 interface module, use the IPC (RS-232C) or PS5000 (RS-422/485) cable diagrams. However, when using PFXZPBMPR42P2 in a RS-422/485 (4-wire) configuration with no flow control, connect 7.RTS+ and 8.CTS+, and connect 6.RTS- and 9.CTS-.
When using RS-422/485 communication with External Devices, you may need to reduce the transmission speed and increase the TX Wait time.
- *6 To use RS-422/485 communication on the RS-232C/422/485 interface module, the DIP Switch setting is required. Please refer to "Knowledge Base" (FAQs) on the support site. (<http://www.pro-face.com/trans/en/manual/1001.html>)

Settings	FAQ ID
PFXZPBMPR42P2, RS422/485 change method	FA263858
PFXZPBMPR42P2 termination resistor setting	FA263974
PFXZPBMPR44P2, RS422/485 change method	FA264087
PFXZPBMPR44P2 termination resistor setting	FA264088

- *7 Set up the SIO type with the DIP Switch. Please refer to the IPC manual for details of DIP Switch. The BOX Atom has not a switch to set the RS-232C, RS-422/485 mode. Use the BIOS for the setting.
- *8 For the connection with the External Device, on the user-created cable read as if the connector on the Display-side is a M12 A-coding 8 pin socket. The pin assignment is the same as described in the cable diagram. For the M12 A-coding connector, use PFXZPSCNM122.

DIP Switch settings (PL3000 / PS3000 Series)

RS-232C

DIP Switch	Setting	Description
1	OFF*1	Reserved (always OFF)
2	OFF	SIO type: RS-232C
3	OFF	
4	OFF	Output mode of SD (TXD) data: Always output
5	OFF	Terminal resistance (220Ω) insertion to SD (TXD): None
6	OFF	Terminal resistance (220Ω) insertion to RD (RXD): None
7	OFF	Short-circuit of SDA (TXA) and RDA (RXA): Not available
8	OFF	Short-circuit of SDB (TXB) and RDB (RXB): Not available
9	OFF	RS (RTS) Auto control mode: Disabled
10	OFF	

*1 When using PS-3450A, PS-3451A, PS3000-BA and PS3001-BD, turn ON the set value.

RS-422/485 (4 wire)

DIP Switch	Setting	Description
1	OFF	Reserved (always OFF)
2	ON	SIO type: RS-422/485
3	ON	
4	OFF	Output mode of SD (TXD) data: Always output
5	OFF	Terminal resistance (220Ω) insertion to SD (TXD): None
6	OFF	Terminal resistance (220Ω) insertion to RD (RXD): None
7	OFF	Short-circuit of SDA (TXA) and RDA (RXA): Not available
8	OFF	Short-circuit of SDB (TXB) and RDB (RXB): Not available
9	OFF	RS (RTS) Auto control mode: Disabled
10	OFF	

RS-422/485 (2 wire)

DIP Switch	Setting	Description
1	OFF	Reserved (always OFF)
2	ON	SIO type: RS-422/485
3	ON	
4	OFF	Output mode of SD (TXD) data: Always output
5	OFF	Terminal resistance (220Ω) insertion to SD (TXD): None
6	OFF	Terminal resistance (220Ω) insertion to RD (RXD): None
7	ON	Short-circuit of SDA (TXA) and RDA (RXA): Available
8	ON	Short-circuit of SDB (TXB) and RDB (RXB): Available
9	ON	RS (RTS) Auto control mode: Enabled
10	ON	

2 Selection of External Device

Select the External Device to be connected to the Display.

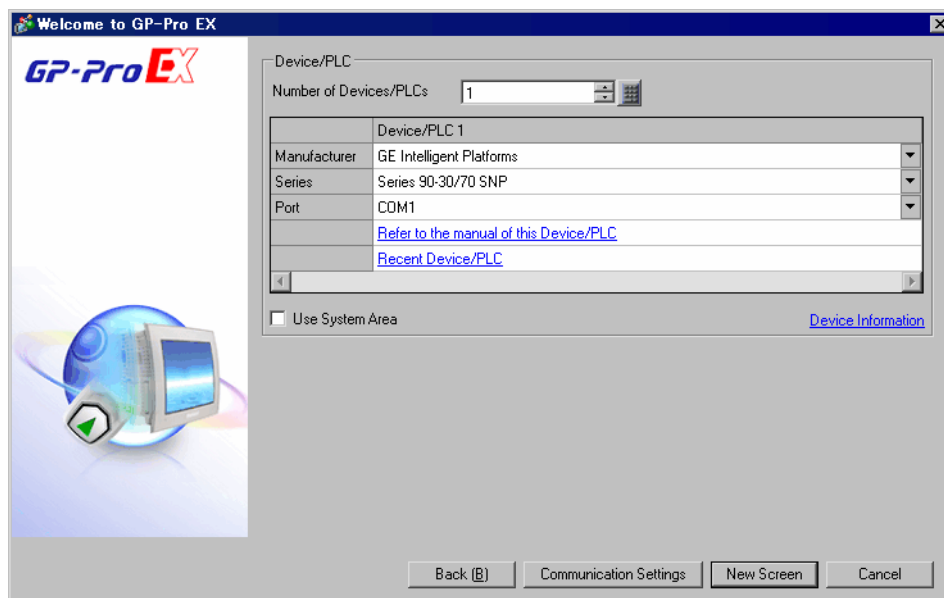

Setup Items	Setup Description
Number of Devices/ PLCs	Enter an integer from 1 to 4 to define the number of Devices/PLCs to connect to the display.
Manufacturer	Select the manufacturer of the External Device to connect. Select "GE Intelligent Platforms".
Series	Select the External Device model (series) and the connection method. Select "Series 90-30/70 SNP". In System configuration, make sure the External Device you are connecting is supported by "Series 90-30/70 SNP".  "1 System Configuration" (page 3)
Port	Select the Display port to be connected to the External Device.
Use System Area	Check this option to synchronize the system data area of the Display and the device (memory) of the External Device. When synchronized, you can use the External Device's ladder program to switch the display or display the window on the Display. Cf. GP-Pro EX Reference Manual "LS Area (Direct Access Method Area)" This feature can also be set in GP-Pro EX or in the Display's offline mode. Cf. GP-Pro EX Reference Manual "System Settings [Display Unit] - [System Area] Settings Guide" Cf. Maintenance/Troubleshooting Guide "Main Unit - System Area Settings"

3 Example of Communication Setting

Examples of communication settings of the Display and the External Device, recommended by Pro-face, are shown.

3.1 Setting Example 1

■ Settings of GP-Pro EX

◆ Communication Settings

To display the setup screen, from the [Project] menu, point to [System Settings] and select [Device/PLC].

◆ Device Setting

To display the [Individual Device Settings] dialog box, from [Device-Specific Settings] in the [Device/PLC] window, select the external device and click [Settings] .

To connect multiple External Devices, from [Device-Specific Settings] in the [Device/PLC] window, click [Add Device] to add another External Device.

■ Settings of External Device

Use the ladder software for communication settings. (Check the operation in CIMPLICITY Machine Edition V4.50)

- 1 Select "Add Target" -> "GE Fanuc PLC" among "Project" of tool bar and select the series to be connected.
The selected series is added as "Target" in the project.
- 2 Allocate the power supply module and the CPU module in "Hardware Configuration" -> "Main Rack" of added Target.

NOTE • The Rack number and Slot number to allocate by environment using are different.
Check the environment, and allocate the Rack number and Slot number.

- 3 Double-click the CPU module, display the setting window.
- 4 Click the [Settings] tab and set the communication settings.
- 5 Forward the communication settings to the external device and spend a power supply of the external device again.

◆ Setup Items

Setup Items	Setup Description
Data Rate [bps]	19200
Parity	Odd
Stop Bits	1
Idle Time [Sec]	10
SNP ID	1

◆ Notes

- Please refer to the manual of the ladder software for more detail on other setting description.

3.2 Setting Example 2

■ Settings of GP-Pro EX

◆ Communication Settings

To display the setup screen, from the [Project] menu, point to [System Settings] and select [Device/PLC]..

The screenshot shows the 'Device/PLC 1' configuration window. The 'Summary' section includes:

- Manufacturer: GE Intelligent Platforms
- Series: Series 90-30/70 SNP
- Port: CDM1
- Text Data Mode: 1 (Change)

 The 'Communication Settings' section includes:

- SIQ Type: RS232C, RS422/485(2wire), RS422/485(4wire)
- Speed: 19200
- Data Length: 7, 8
- Parity: NONE, EVEN, ODD
- Stop Bit: 1, 2
- Flow Control: NONE, ER(DTR/CTS), XON/XOFF
- Timeout: 3 (sec)
- Retry: 2
- Wait To Send: 0 (ms)

 Below these settings is a section for 'RI / VCC' with radio buttons for 'RI' and 'VCC'. A note states: 'In the case of RS232C, you can select the 9th pin to RI (Input) or VCC (5V Power Supply). If you use the Digital's RS232C Isolation Unit, please select it to VCC.' A 'Default' button is also present.

 The 'Device-Specific Settings' section shows:

- Allowable Number of Devices/PLCs: 16 (Add Device)
- A table with columns 'No.', 'Device Name', and 'Settings'. The first entry is '1', 'PLC1', and 'Idle Time(Sec)=5,CPU ID=1'. There is an 'Add Indirect Device' button to the right.

◆ Device Setting

To display the [Individual Device Settings] dialog box, from [Device-Specific Settings] in the [Device/PLC] window, select the external device and click [Settings] .

To connect multiple External Devices, from [Device-Specific Settings] in the [Device/PLC] window, click [Add Device] to add another External Device.

The 'Individual Device Settings' dialog box for 'PLC1' contains:

- Idle Time(Sec): 5
- CPU ID: 1
- Series 90-30: 6 characters max (0-9,A-F,_)
- Series 90-70: 7 characters max (0-9,A-Z,a-z,_)
- Buttons: Default, OK (O), Cancel

■ Settings of External Device

Use the ladder software for communication settings. (Check the operation in CIMPLICITY Machine Edition V4.50)

- 1 Select "Add Target" -> "GE Fanuc PLC" among "Project" of tool bar and select the series to be connected.
The selected series is added as "Target" in the project.
- 2 Allocate the power supply module and the CPU module in "Hardware Configuration" -> "Main Rack" of added Target.

NOTE • The Rack number and Slot number to allocate by environment using are different.
Check the environment, and allocate the Rack number and Slot number.

- 3 Double-click the CPU module, display the setting window.
- 4 Click the [Settings] tab and set the communication settings.
- 5 Forward the communication settings to the external device and spend a power supply of the external device again.

◆ Setup Items

Setup Items	Setup Description
Data Rate [bps]	19200
Data Bits	8
Parity	Odd
Stop Bits	1
Idle Time [Sec]	5
SNP ID	1

◆ Notes

Please refer to the manual of the ladder software for more detail on other setting description.

4 Setup Items

Set communication settings of the Display with GP-Pro EX or in offline mode of the Display.

The setting of each parameter must be identical to that of External Device.

☞ "3 Example of Communication Setting" (page 9)

4.1 Setup Items in GP-Pro EX

■ Communication Settings

To display the setup screen, from the [Project] menu, point to [System Settings] and select [Device/PLC].

Device/PLC 1

Summary [Change Device/PLC](#)

Manufacturer Series Port

Text Data Mode [Change](#)

Communication Settings

SIO Type RS232C RS422/485(2wire) RS422/485(4wire)

Speed

Data Length 7 8

Parity NONE EVEN ODD

Stop Bit 1 2

Flow Control NONE ER(DTR/CTS) XON/XOFF

Timeout (sec)

Retry

Wait To Send (ms)

RI / VCC RI VCC

In the case of RS232C, you can select the 9th pin to RI (Input) or VCC (5V Power Supply). If you use the Digital's RS232C Isolation Unit, please select it to VCC.

Device-Specific Settings

Allowable Number of Devices/PLCs [Add Device](#)

No.	Device Name	Settings	<input type="button" value="Add Indirect Device"/>
1	<input type="text" value="PLC1"/>	<input type="text" value="Idle Time(Sec)=5,CPU ID=1"/>	<input type="button" value="+"/>

Setup Items	Setup Description
SIO Type	Display the SIO type to communicate with the External Device.
Speed	Select speed between the External Device and the Display.
Data Length	Display data length.
Parity	Select how to check parity.
Stop Bit	Select stop bit length.
Flow Control	Display the communication control method to prevent overflow of transmission and reception data.
Timeout	Use an integer from 1 to 127 to enter the time (s) for which the Display waits for the response from the External Device.
Retry	In case of no response from the External Device, use an integer from 0 to 255 to enter how many times the Display retransmits the command.
Wait To Send	Use an integer from 0 to 255 to enter standby time (ms) for the Display from receiving packets to transmitting next commands.

NOTE

- Refer to the GP-Pro EX Reference Manual for Indirect Device.

Cf. GP-Pro EX Reference Manual "Changing the Device/PLC at Runtime (Indirect Device)"

◆ Device Setting

To display the [Individual Device Settings] dialog box, from [Device-Specific Settings] in the [Device/PLC] window, select the external device and click [Settings] .

To connect multiple External Devices, from [Device-Specific Settings] in the [Device/PLC] window, click [Add Device] to add another External Device.

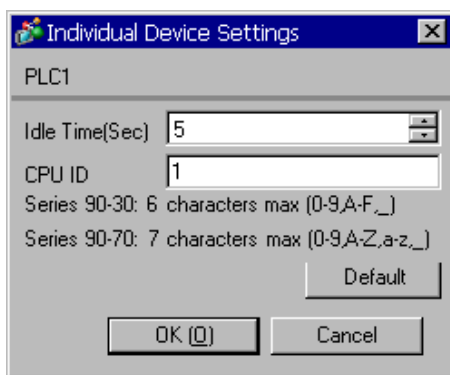

Setup Items	Setup Description
Idle Time[Sec]	Set the Idle Time of External Device. Please set same Idle Time as the setting of External Device. Use an integer from 1 to 60 to enter the time (Sec).
CPU ID	Set the CPU ID of External Device. Please set same CPU ID as the setting of External Device. CPU ID can be set within the following ranges. Series 90-30: It is the maximum and is character of six characters. ['0'-'9', 'A'-'F', '_'] Series 90-70: It is the maximum and is character of seven characters. ['0'-'9', 'A'-'Z', 'a'-'z', '_']

4.2 Setup Items in Offline Mode

- NOTE**
- Refer to the Maintenance/Troubleshooting guide for information on how to enter offline mode and how to operate offline mode.
 - Cf. Maintenance/Troubleshooting Guide "Offline Mode"
 - The number of the setup items to be displayed for 1 page in the offline mode depends on the Display in use. Please refer to the Reference manual for details.

◆ Communication Settings

To display the setting screen, touch [Device/PLC Settings] from [Peripheral Settings] in offline mode. Touch the External Device you want to set from the displayed list.

Comm.	Device	Option		
Series 90-30/70 SNP			[COM1]	Page 1/1
SIO Type			RS422/485(4wire)	
Speed			19200	
Data Length			8	
Parity			<input type="radio"/> NONE <input type="radio"/> EVEN <input checked="" type="radio"/> ODD	
Stop Bit			<input checked="" type="radio"/> 1 <input type="radio"/> 2	
Flow Control			NONE	
Timeout(s)			3	▼ ▲
Retry			2	▼ ▲
Wait To Send(ms)			0	▼ ▲
	Exit		Back	2008/01/08 19:22:57

Setup Items	Setup Description
SIO Type	Display the SIO type to communicate with the External Device. IMPORTANT To make the communication settings correctly, confirm the serial interface specifications of Display unit for [SIO Type]. We cannot guarantee the operation if a communication type that the serial interface does not support is specified. For details concerning the serial interface specifications, refer to the manual for Display unit.
Speed	Select speed between the External Device and the Display.
Data Length	Display data length.
Parity	Select how to check parity.
Stop Bit	Select stop bit length.
Flow Control	Display the communication control method to prevent overflow of transmission and reception data.

Setup Items	Setup Description
Timeout	Use an integer from 1 to 127 to enter the time (s) for which the Display waits for the response from the External Device.
Retry	In case of no response from the External Device, use an integer from 0 to 255 to enter how many times the Display retransmits the command.
Wait To Send	Use an integer from 0 to 255 to enter standby time (ms) for the Display from receiving packets to transmitting next commands.

◆ Device Setting

To display the setting screen, touch [Device/PLC Settings] from [Peripheral Settings]. Touch the External Device you want to set from the displayed list, and touch [Device]..

Comm.	Device	Option		
Series 90-30/70 SNP			[COM1]	Page 1/1
Device/PLC Name	PLC1			
Idle Time(Sec)	5			
CPU ID	1			
	Series 90-30: 6 characters max (0-9, A-F, _)			
	Series 90-70: 7 characters max (0-9, A-Z, a-z, _)			
	Exit		Back	2008/01/09 00:23:19

Setup Items	Setup Description
Device/PLC Name	Select the External Device for device setting. Device name is a title of External Device set with GP-Pro EX.(Initial value [PLC1])
Idle Time(Sec)	Set the Idle Time of External Device. Please set same Idle Time as the setting of External Device. Use an integer from 1 to 60 to enter the time (Sec).
CPU ID	Set the CPU ID of PLC. Please set same CPU ID as the setting of External Device. CPU ID can be set within the following ranges. Series 90-30: It is the maximum and is character of six characters. ['0'-'9', 'A'-'F', '_'] Series 90-70: It is the maximum and is character of seven characters. ['0'-'9', 'A'-'Z', 'a'-'z', '_'] IMPORTANT • For GP-4100 series, an under bar character ("_") cannot be input. Input it using GP-Pro EX.

5 Cable Diagram

The cable diagram shown below may be different from the cable diagram recommended by GE Intelligent Platforms. Please be assured there is no operational problem in applying the cable diagram shown in this manual.



- The FG pin of the External Device body must be D-class grounded. Please refer to the manual of the External Device for more details.
- SG and FG are connected inside the Display. When connecting SG to the External Device, design the system not to form short-circuit loop.
- Connect the isolation unit, when communication is not stabilized under the influence of a noise etc..

Cable Diagram 1

Display (Connection Port)	Cable		Notes
GP3000* ¹ (COM1) AGP-3302B (COM2) GP-4*0ITM (COM1) GP-Rear Module (COM1) ST* ² (COM2) IPC* ³	1A	COM port conversion adapter by Pro-face CA3-ADPCOM-01 + Terminal block conversion adapter by Pro-face CA3-ADPTRM-01 + Your own cable	The cable length must be 1000m or less.
	1B	Your own cable	
GP3000* ⁴ (COM2)	1C	Online adapter by Pro-face CA4-ADPONL-01 + Terminal block conversion adapter by Pro-face CA3-ADPTRM-01 + Your own cable	The cable length must be 1000m or less.
	1D	Online adapter by Pro-face CA4-ADPONL-01 + Your own cable	
GP4000* ⁵ (COM2) GP-4201T (COM1) SP5000* ⁶ (COM1/2) SP-5B00 (COM2)	1E	RS-422 Terminal Block Conversion Adapter by Pro-face PFXZCBADTM1* ⁷ + Your own cable	The cable length must be 1000m or less.
	1B	Your own cable	
GP-4106 (COM1) GP-4116T (COM1)	1F	Your own cable	The cable length must be 1000m or less.
PE-4000B* ⁸ PS5000* ⁸	1G	Your own cable	The cable length must be 1000m or less.

*1 All GP models except AGP-3302B

*2 All ST models except AST-3211A and AST-3302B

- *3 Only the COM port which can communicate by RS-422/485 (4 wire) can be used. (Except PE-4000B, PS5000)
 ■ IPC COM Port (page 5)
- *4 All GP models except GP-3200 series and AGP-3302B
- *5 All GP4000 models except GP-4100 Series, GP-4*01TM, GP-Rear Module, GP-4201T and GP-4*03T
- *6 Except SP-5B00
- *7 When using a Terminal Block Conversion Adapter (CA3-ADPTRM-01) instead of the RS-422 Terminal Block Conversion Adapter, refer to Cable Diagram 1A.
- *8 Only the COM port which can communicate by RS-422/485 (4 wire) can be used.
 ■ IPC COM Port (page 5)

1A)

- 1:1 Connection

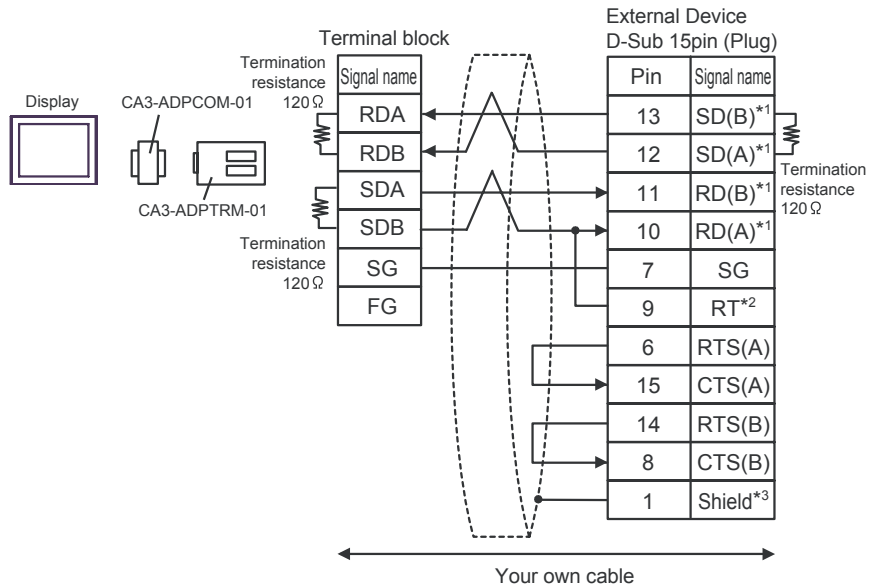

- 1:n Connection

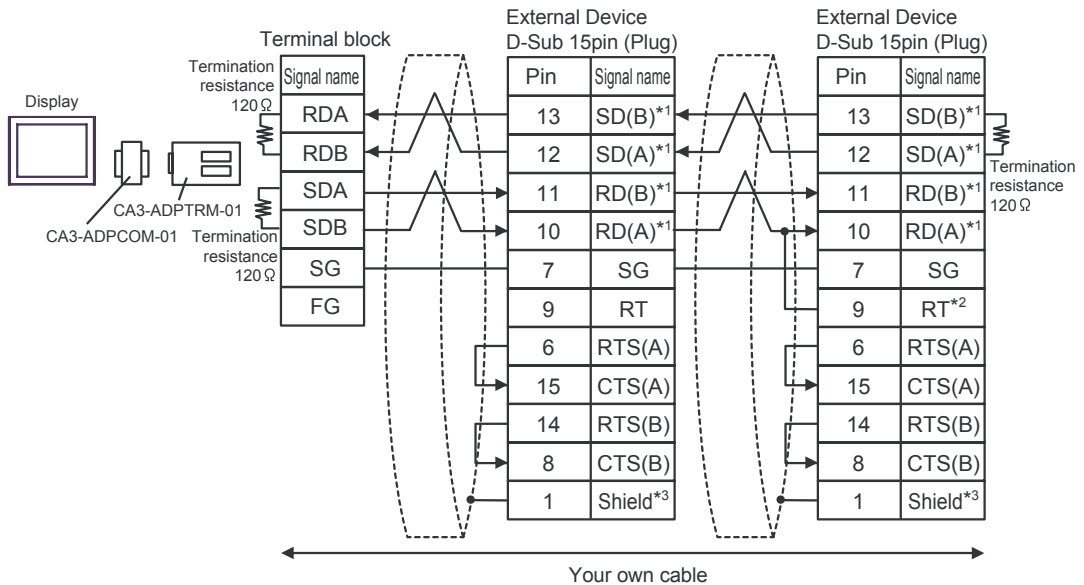

*1: Notation of RD(A), RD(B), SD(A) and SD(B) are different by the external device.

Please refer to the manual of the external device.

In addition, note that Class A and Class B are reversely named for the Display and the External Device.

*2: Insert the termination resistance of the external device side. The 120Ω termination resistance is inserted between RDA - RDB by connecting the 9th pin to the 10th pin of serial interface at the external device side. But termination resistance is inserted in CPU731 and CPU771 by connecting the 9th pin to the 11th pin.

*3: FG of the external device ground the D class grounding. In addition, FG connection to a shield line select the external device side, either display side by location environment.

1B)

- 1:1 Connection

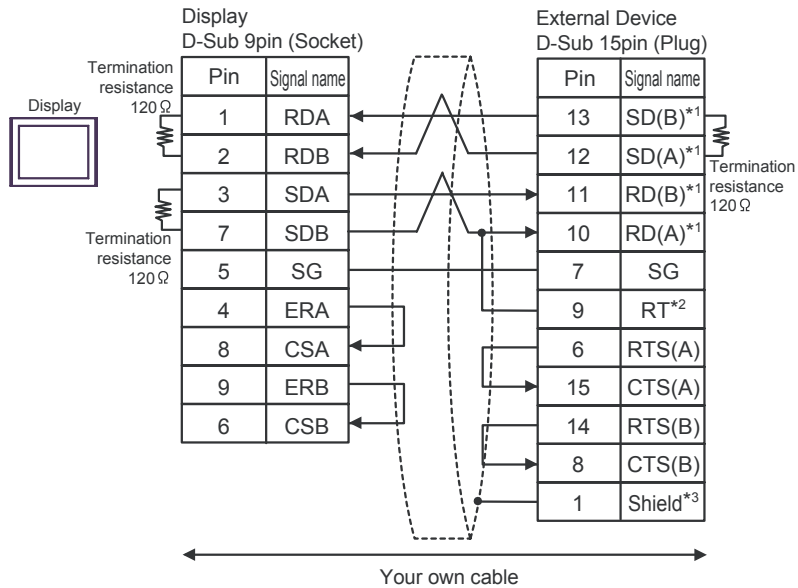

- 1:n Connection

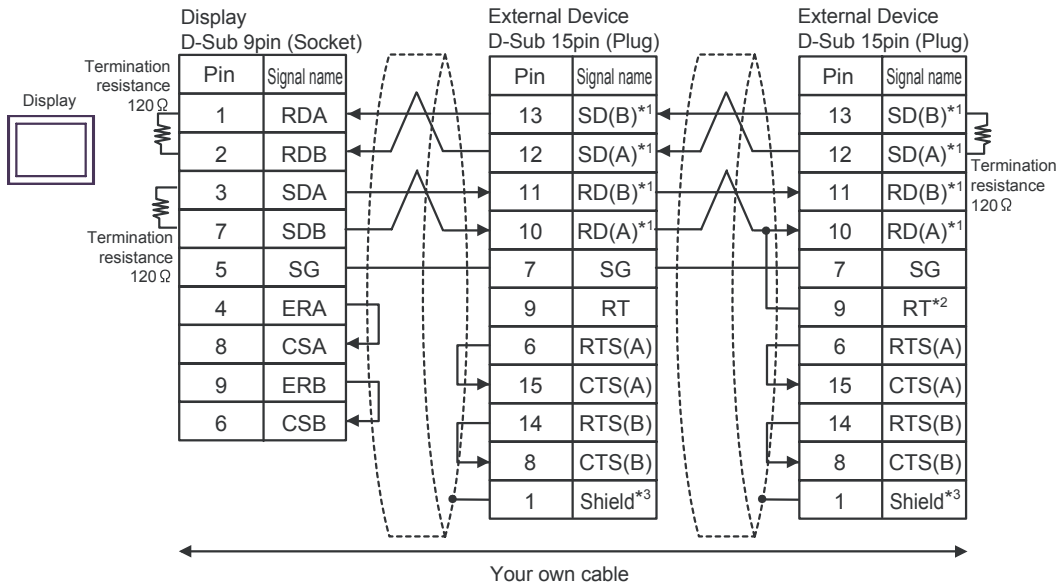

*1: Notation of RD(A), RD(B), SD(A) and SD(B) are different by the external device.

Please refer to the manual of the external device.

In addition, note that Class A and Class B are reversely named for the Display and the External Device.

*2: Insert the termination resistance of the external device side. The 120 Ω termination resistance is inserted between RDA - RDB by connecting the 9th pin to the 10th pin of serial interface at the external device side. But termination resistance is inserted in CPU731 and CPU771 by connecting the 9th pin to the 11th pin.

*3: FG of the external device ground the D class grounding. In addition, FG connection to a shield line select the external device side, either display side by location environment.

1C)

- 1:1 Connection

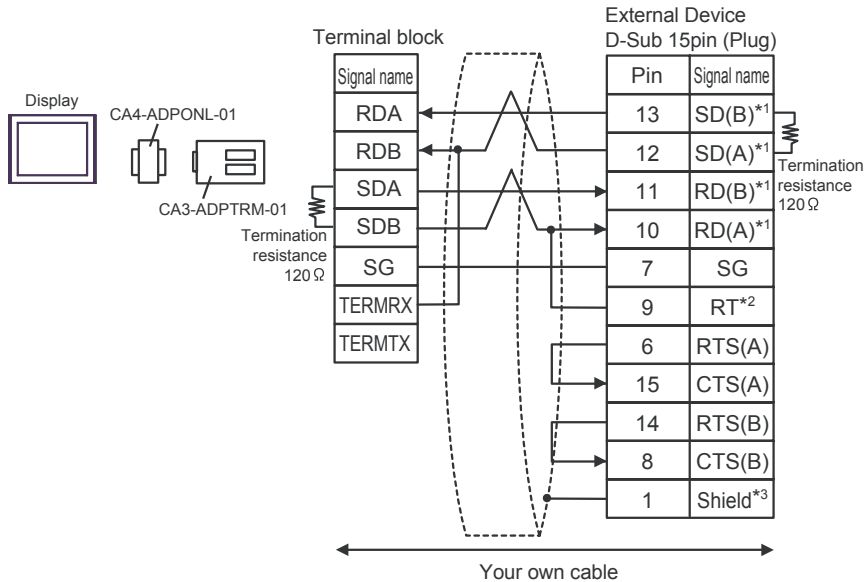

- 1:n Connection

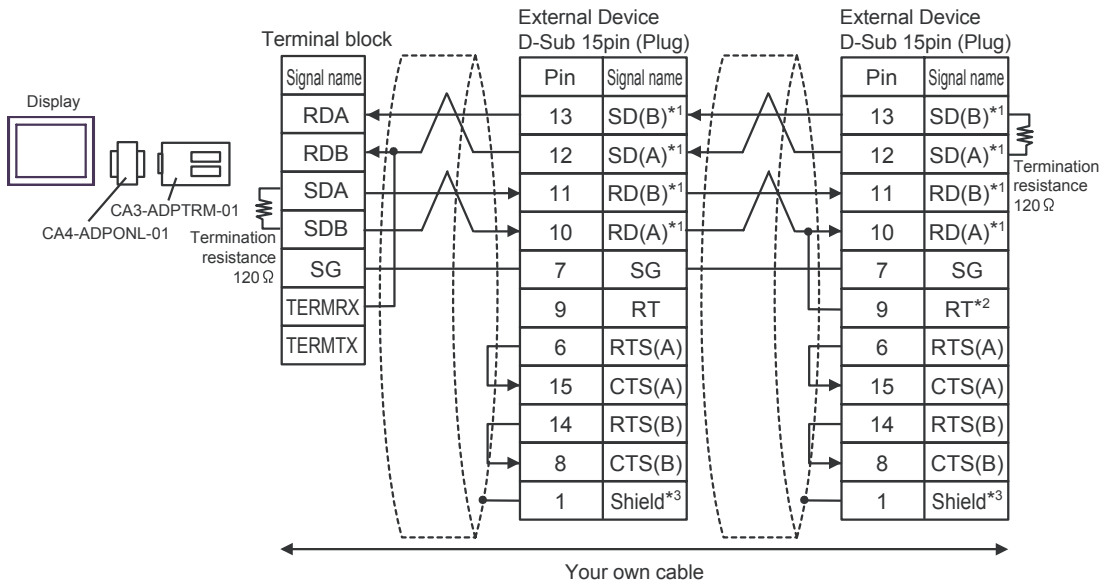

*1: Notation of RD(A), RD(B), SD(A) and SD(B) are different by the external device.

Please refer to the manual of the external device.

In addition, note that Class A and Class B are reversely named for the Display and the External Device.

*2: Insert the termination resistance of the external device side. The 120 Ω termination resistance is inserted between RDA - RDB by connecting the 9th pin to the 10th pin of serial interface at the external device side. But termination resistance is inserted in CPU731 and CPU771 by connecting the 9th pin to the 11th pin.

*3: FG of the external device ground the D class grounding. In addition, FG connection to a shield line select the external device side, either display side by location environment.

1D)

- 1:1 Connection

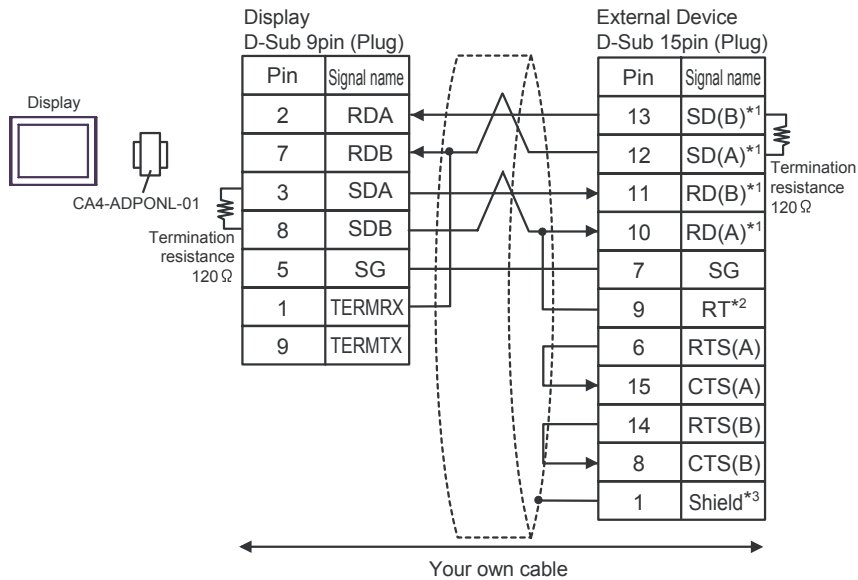

- 1:n Connection

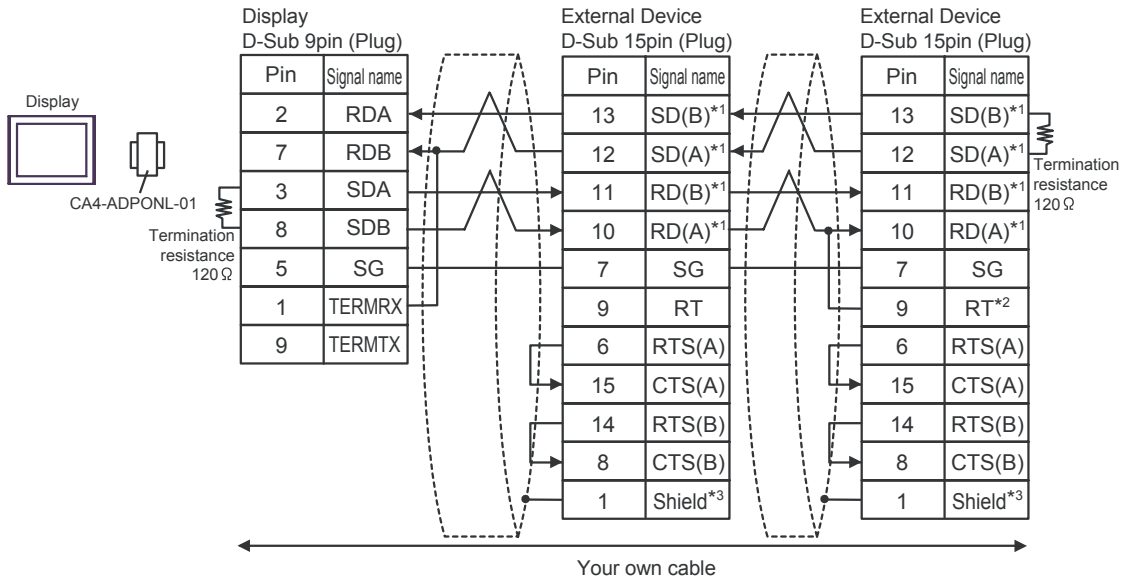

*1: Notation of RD(A), RD(B), SD(A) and SD(B) are different by the external device.

Please refer to the manual of the external device.

In addition, note that Class A and Class B are reversely named for the Display and the External Device.

*2: Insert the termination resistance of the external device side. The 120Ω termination resistance is inserted between RDA - RDB by connecting the 9th pin to the 10th pin of serial interface at the external device side. But termination resistance is inserted in CPU731 and CPU771 by connecting the 9th pin to the 11th pin.

*3: FG of the external device ground the D class grounding. In addition, FG connection to a shield line select the external device side, either display side by location environment.

1E)

- 1:1 Connection

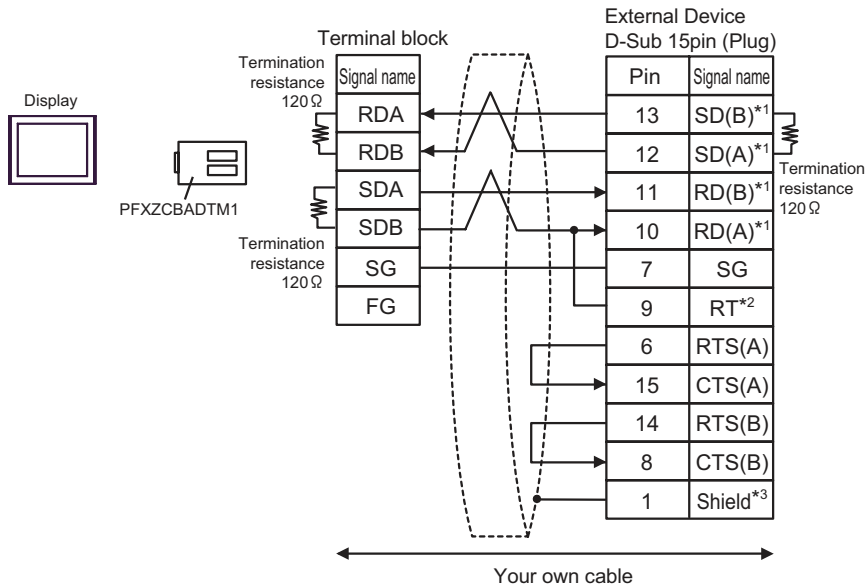

- 1:n Connection

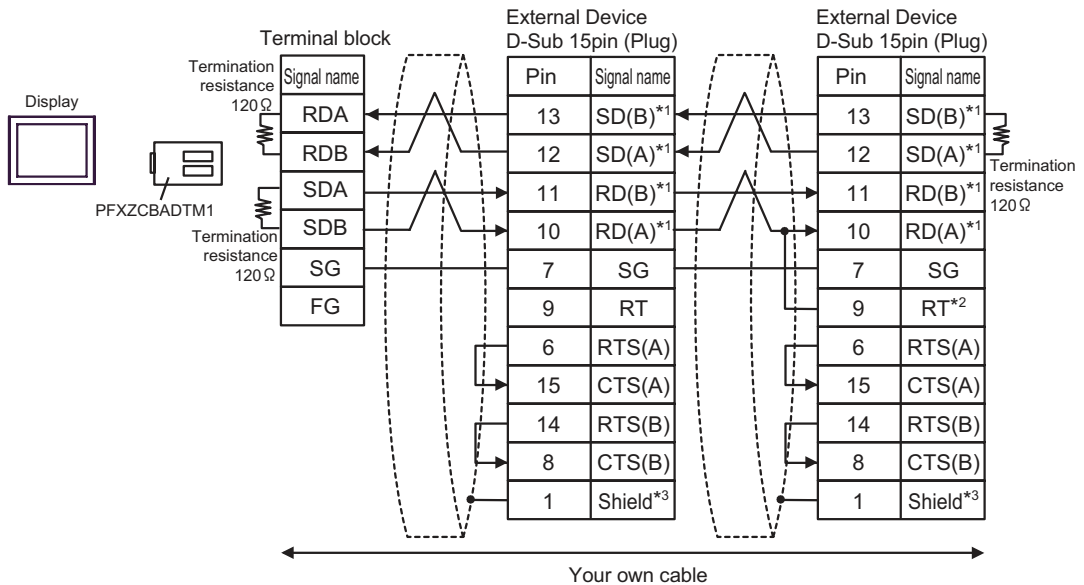

*1: Notation of RD(A), RD(B), SD(A) and SD(B) are different by the external device.

Please refer to the manual of the external device.

In addition, note that Class A and Class B are reversely named for the Display and the External Device.

*2: Insert the termination resistance of the external device side. The 120Ω termination resistance is inserted between RDA - RDB by connecting the 9th pin to the 10th pin of serial interface at the external device side. But termination resistance is inserted in CPU731 and CPU771 by connecting the 9th pin to the 11th pin.

*3: FG of the external device ground the D class grounding. In addition, FG connection to a shield line select the external device side, either display side by location environment.

1F)

- 1:1 Connection

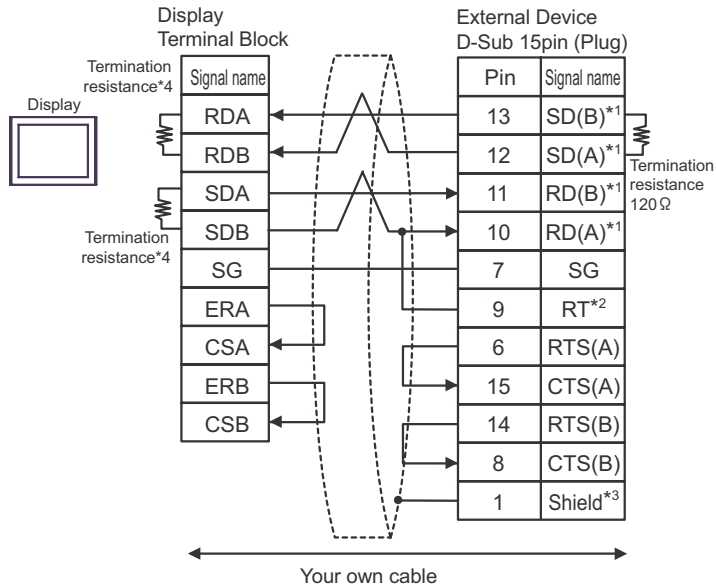

- 1:n Connection

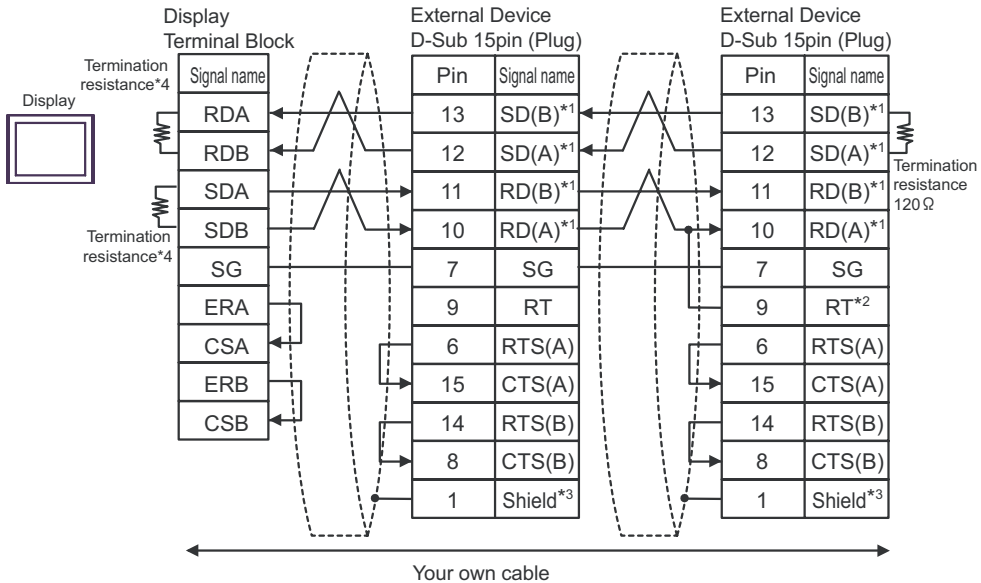

*1: Notation of RD(A), RD(B), SD(A) and SD(B) are different by the external device.

Please refer to the manual of the external device.

In addition, note that Class A and Class B are reversely named for the Display and the External Device.

*2: Insert the termination resistance of the external device side. The 120Ω termination resistance is inserted between RDA - RDB by connecting the 9th pin to the 10th pin of serial interface at the external device side. But termination resistance is inserted in CPU731 and CPU771 by connecting the 9th pin to the 11th pin.

*3: FG of the external device ground the D class grounding. In addition, FG connection to a shield line select the external device side, either display side by location environment.

*4: The resistance in the Display is used as the termination resistance. Set the value of the DIP Switch on the rear of the Display as shown in the table below.

DIP Switch No.	Set Value
1	ON
2	ON
3	ON
4	ON

1G)

- 1:1 Connection

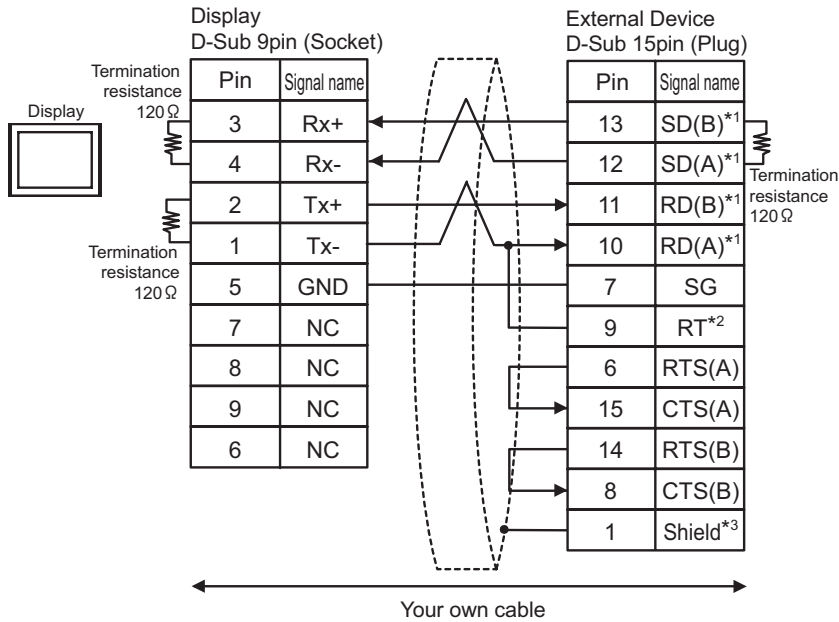

- 1:n Connection

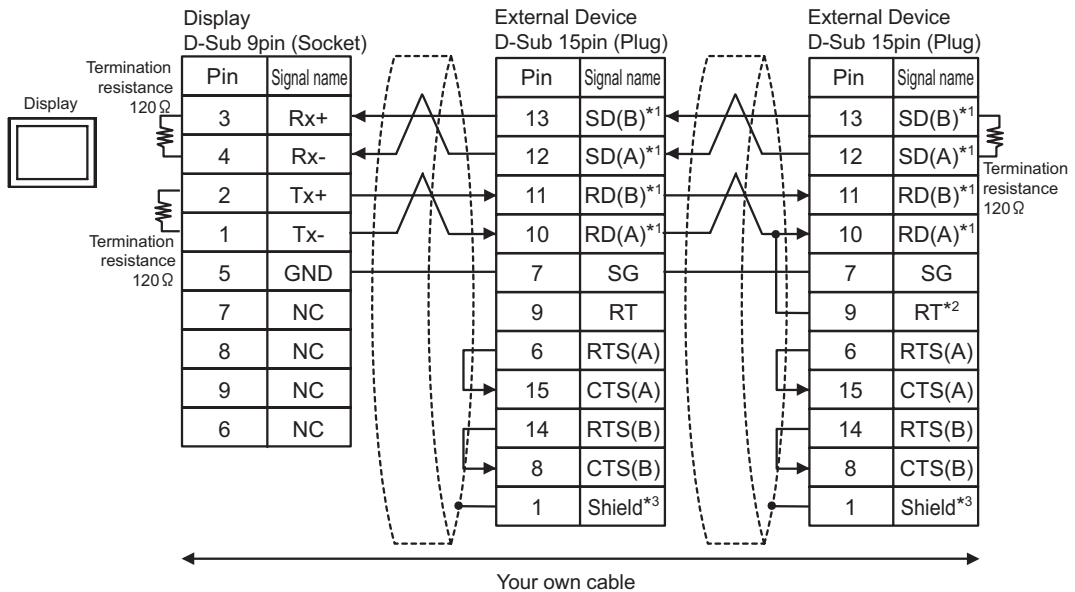

*1: Notation of RD(A), RD(B), SD(A) and SD(B) are different by the external device.

Please refer to the manual of the external device.

In addition, note that Class A and Class B are reversely named for the Display and the External Device.







*2: Insert the termination resistance of the external device side. The 120 Ω termination resistance is inserted between RDA - RDB by connecting the 9th pin to the 10th pin of serial interface at the external device side. But termination resistance is inserted in CPU731 and CPU771 by connecting the 9th pin to the 11th pin.

*3: FG of the external device ground the D class grounding. In addition, FG connection to a shield line select the external device side, either display side by location environment.

6 Supported Device

Range of supported device address is shown in the table below. Please note that the actually supported range of the devices varies depending on the External Device to be used. Please check the actual range in the manual of your connecting equipment.

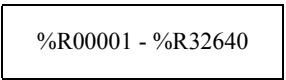
 This address can be specified as system data area.

Device	Bit Address	Word Address	32 bits	Notes
Discrete inputs	%I00001 - %I12288	%I00001 - %I12273		
Discrete outputs	%Q00001 - %Q12288	%Q00001 - %Q12273		
Discrete Globals	%G00001 - %G07680	%G00001 - %G07665		
Internal coils	%M00001 - %M12288	%M00001 - %M12273		
Temporary coils	%T00001 - %T00256	%T00001 - %T00241		
System status references	%S00001 - %S00128	%S00001 - %S00113		 *1
	%SA00001 - %SA00128	%SA00001 - %SA00113		
	%SB00001 - %SB00128	%SB00001 - %SB00113		
	%SC00001 - %SC00128	%SC00001 - %SC00113		
System register references	-----	 %R00001 - %R32640		
Analog inputs	-----	%AI00001 - %AI32640		
Analog outputs	-----	%AQ00001 - %AQ32640		

*1 Write disable

NOTE

- Please refer to the GP-Pro EX Reference Manual for system data area.
Cf. GP-Pro EX Reference Manual "LS Area (Direct Access Method Area)"
- Please refer to the precautions on manual notation for icons in the table.
 "Manual Symbols and Terminology"

7 Device Code and Address Code

Use device code and address code when you select "Device Type & Address" for the address type in data displays.

Device	Device Name	Device Code (HEX)	Address Code
Discrete inputs	%I	0080	(Word address - 1) / 16
Discrete outputs	%Q	0081	(Word address - 1) / 16
Discrete Globals	%M	0083	(Word address - 1) / 16
Internal coils	%G	0082	(Word address - 1) / 16
Temporary coils	%T	0084	(Word address - 1) / 16
System status references	%SA	0086	(Word address - 1) / 16
	%SB	0087	(Word address - 1) / 16
	%SC	0088	(Word address - 1) / 16
	%S	0085	(Word address - 1) / 16
System register references	%R	0000	Word address - 1
Analog inputs	%AI	0001	Word address - 1
Analog outputs	%AQ	0002	Word address - 1

8 Error Messages

Error messages are displayed on the screen of Display as follows: "No. : Device Name: Error Message (Error Occurrence Area)". Each description is shown below.

Item	Description
No.	Error No.
Device Name	Name of External Device where error occurs. Device name is a title of External Device set with GP-Pro EX. (Initial value [PLC1])
Error Message	Displays messages related to the error which occurs.
Error Occurrence Area	<p>Displays IP address or device address of External Device where error occurs, or error codes received from External Device.</p> <p>NOTE</p> <ul style="list-style-type: none"> • IP address is displayed such as "IP address (Decimal): MAC address (Hex)". • Device address is displayed such as "Address: Device address". • Received error codes are displayed such as "Decimal [Hex]".

Display Examples of Error Messages

"RHAA035: PLC1: Error has been responded for device write command (Error Code: 2 [02H])"

NOTE

- Refer to your External Device manual for details on received error codes.
- Refer to "Display-related errors" in "Maintenance/Troubleshooting Guide" for details on the error messages common to the driver.

■ Error Code Peculiar to External Device

The error code characteristic of the external device is displayed in 2 Byte of "Major Error Status Code (1 Byte)" and "Minor Error Status Code (1 Byte)".

When received the error code from the external device, add to the below message. "Major Error Status Code" is displayed continuously "Major" and "Minor Error Status Code" is displayed continuously "Minor".

For details of the error code, please refer to the manual of the external device.

The error code peculiar to the external device is as follows.

Message ID	Error Message	Description
RHxx128	(Node Name): Error has been responded for device read command (Major:[%02Xh], Minor:[%02Xh])	Display the error message, when the error occurred by the reading demand.
RHxx129	(Node Name): Error has been responded for device write command (Major:[%02Xh], Minor:[%02Xh])	Display the error message, when the error occurred by the write demand.
RHxx130	(Node Name): Error has been responded for device write command (Major:[%02Xh], Minor:[%02Xh] There are read only devises)	Display the error message, when write for the read only device.