



# Hand-held GP Connection Guide

1	System Configuration.....	3
2	Optional Items .....	5
3	Connection Configuration.....	7

## Introduction

This manual describes GP3000H accessories required to connect the Hand-held GP display unit (hereinafter referred to as "Display") and the External Device (target PLC). Refer to the Hardware Manual for details on the Display.

Depending on the External Device, different types of connection cables are used for connecting the GP3000H accessories. Refer to the External Device connection manual for corresponding External Device details.

- Connection Configuration of Display

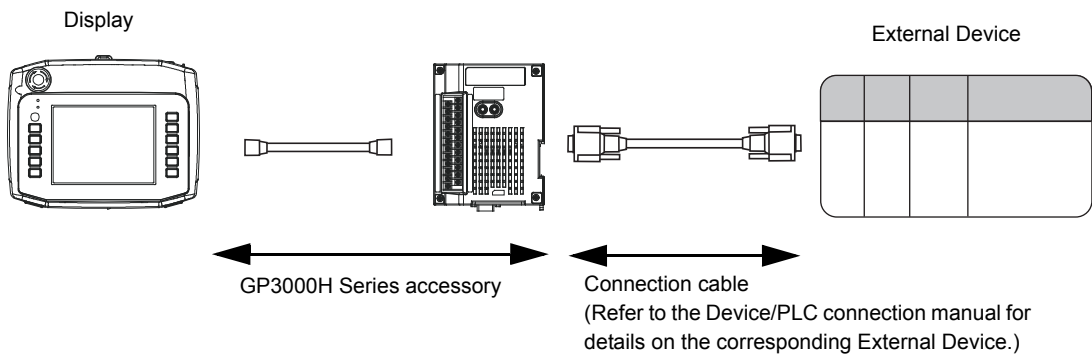

# 1 System Configuration

The following section lists system configurations for connecting the External Device and the Display.

Display	Optional Items	SIO Type	System Configuration
GP3000H	GP3000H Direct-connect cable (with connector) GP3000H-CBL■D-□M and GP3000H Conversion Adapter AGP3000H-ADPCOM-01	RS-232C	"Configuration 1" (page 7)
		RS-422/485 (4 wire)	"Configuration 1" (page 7)
		RS-422/485 (4 wire) Serial multilink	"Configuration 3" (page 12)
		RS-422/485 (2 wire )	"Configuration 1" (page 7)
		Ethernet (UDP or TCP)	"Configuration 1" (page 7)
	GP3000H Direct-connect cable (without connector) GP3000H-CBL■-□M	RS-232C	"Configuration 2" (page 9)
		RS-422/485 (4 wire)	"Configuration 2" (page 9)
		RS-422/485 (4 wire) Serial multilink	"Configuration 4" (page 14)
		RS-422/485 (2 wire )	"Configuration 2" (page 9)
		Ethernet (UDP or TCP)	"Configuration 2" (page 9)
	GP3000H Soft-type Cable for GP2000H Conversion Adapter <RS-232C> (with connector)* <sup>1</sup> GP3000H-CBLSD232-□M and GP2000H Series RS-232C Conversion Adapter GP2000H-AP232	RS-232C	"Configuration 5" (page 17)
	GP3000H Soft-type Cable for GP2000H Conversion Adapter <RS-232C> (with connector)* <sup>1</sup> GP3000H-CBLSD232-□M and GP2000H Series RS-232C Conversion Adapter GP2000H-AP232 and RS-232C Cable GP410-IS00-O(5m)	RS-232C	"Configuration 6" (page 19)
	GP3000H Soft-type Cable for GP2000H Conversion Adapter <RS-422> (with connector)* <sup>1</sup> GP3000H-CBLSD422-□M and GP2000H series RS-422 Conversion Adapter GP2000H-AP422	RS-422/485 (4 wire or 2 wire)	"Configuration 7" (page 21)

Display	Optional Items	SIO Type	System Configuration
GP4000H	GP3000H Direct-connect cable (with connector) GP3000H-CBL■D-□M and GP3000H Conversion Adapter AGP3000H-ADPCOM-01	RS-232C	"Configuration 1" (page 7)
		RS-422/485 (4 wire)	"Configuration 1" (page 7)
		RS-422/485 (4 wire) Serial multilink	"Configuration 3" (page 12)
		RS-422/485 (2 wire )	"Configuration 1" (page 7)
		Ethernet (UDP or TCP)	"Configuration 1" (page 7)
	GP3000H Direct-connect cable (without connector) GP3000H-CBL■-□M	RS-232C	"Configuration 2" (page 9)
		RS-422/485 (4 wire)	"Configuration 2" (page 9)
		RS-422/485 (4 wire) Serial multilink	"Configuration 4" (page 14)
		RS-422/485 (2 wire )	"Configuration 2" (page 9)
		Ethernet (UDP or TCP)	"Configuration 2" (page 9)

\*1 Be sure to read the installation guide included with the cable for details on usage of the GP2000H series Conversion Adapter.

**NOTE**

- In the cable model names, the ■ symbol represents H or S (for Hard-type or Soft-type). The □ symbol represents 3, 5, or 10 (for meters of cable length).

☞ "2 Optional Items" (page 5)

## 2 Optional Items

### ■ When connecting the External Device directly to the GP3000H/GP4000H

Name	Type	Description
GP3000H Hard-type 10m Direct-connect cable (without connector)	GP3000H-CBLH-10M	Heavy-duty <sup>*1</sup> type interface cable for communication between the Display and External Device (e.g. host controller), equipped with common mode filter.
GP3000H Soft-type 3m Direct-connect cable (without connector)	GP3000H-CBLS-3M	Standard type interface cable for communication between the Display and External Device (e.g. host controller), equipped with common mode filter.
GP3000H Soft-type 5m Direct-connect cable (without connector)	GP3000H-CBLS-5M	
GP3000H Soft-type 10m Direct-connect cable (without connector)	GP3000H-CBLS-10M	

\*1 Heavy-duty type cables are built stronger than Standard type cables, so they can be used in situations where durability is required.

### ■ When connecting the GP3000H Conversion Adapter to the GP3000H/GP4000H

Name	Type	Description
GP3000H Hard-type 10m Direct-connect cable (with connector)	GP3000H-CBLHD-10M	Heavy-duty <sup>*1</sup> type cable between the GP3000H Conversion Adapter and the Display.
GP3000H Soft-type 3m Direct-connect cable (with connector)	GP3000H-CBLSD-3M	Standard type cable between the GP3000H Conversion Adapter and the Display.
GP3000H Soft-type 5m Direct-connect cable (with connector)	GP3000H-CBLSD-5M	
GP3000H Soft-type 10m Direct-connect cable (with connector)	GP3000H-CBLSD-10M	
GP3000H Conversion Adapter	AGP3000H-ADPCOM-01	This is the conversion adapter which converts the output to RS-232C/422/485 serial interface output (D-Sub) or to Ethernet output (RJ-45).

\*1 Heavy-duty type cables are built stronger than Standard type cables, so they can be used in situations where durability is required.

- When connecting the GP2000H Series Conversion Adapter for RS-232C or the GP2000H Series Conversion Adapter for RS-422 to the GP3000H

Name	Type	Description
GP3000H Soft-type 3 m Cable for GP2000H Conversion Adapter <RS-232C> (with connector)	GP3000H-CBLSD232-3M	The cable between the GP2000H Series RS-232C Conversion Adapter and the GP3000H, equipped with D-Sub connector.
GP3000H Soft-type 10 m Cable for GP2000H Conversion Adapter <RS-232C> (with connector)	GP3000H-CBLSD232-10M	
GP2000H Series RS-232C Conversion Adapter	GP2000H-AP232	Conversion adapter to convert serial data to RS-232C D-Sub format.
GP3000H Soft-type 3 m Cable for GP2000H Conversion Adapter <RS-422> (with connector)	GP3000H-CBLSD422-3M	The cable between the GP2000H Series RS-422 Conversion Adapter and the GP3000H, equipped with D-Sub connector.
GP3000H Soft-type 10 m Cable for GP2000H Conversion Adapter <RS-422> (with connector)	GP3000H-CBLSD422-10M	
GP2000H Series RS-422 Conversion Adapter	GP2000H-AP422	Conversion adapter to convert serial data to RS-422 terminal block format.

**IMPORTANT**

- Be sure to read the installation guide included with the GP3000H Soft-type Cable for GP2000H Conversion Adapter for details on usage of the GP2000H Series Conversion Adapter.

## 3 Connection Configuration

### 3.1 Configuration 1

When using the GP3000H Direct-connect cable (with connector) (GP3000H-CBL■D-□M) and GP3000H Conversion Adapter (AGP3000H-ADPCOM-01)

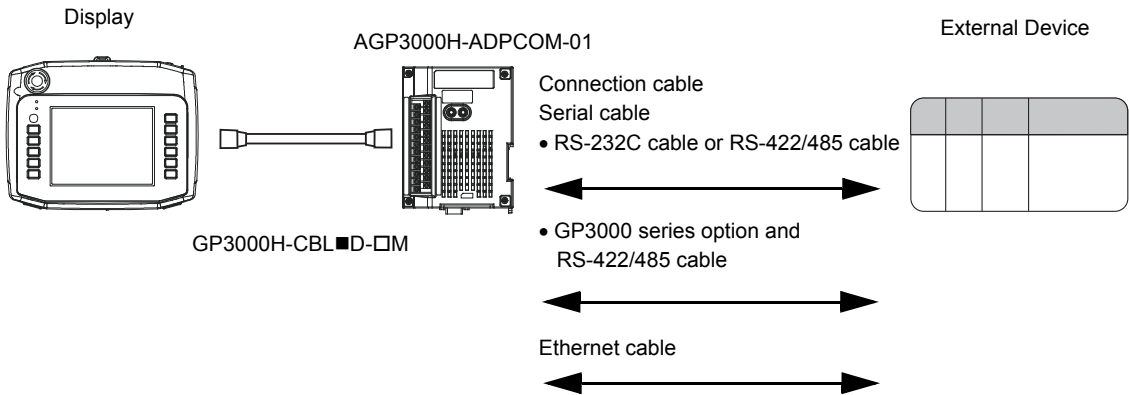

#### IMPORTANT

- Connection cable differs depending on the External Device in use. Check with the Device/PLC connection manual that corresponds to the External Device in use for the content and usage. The Hand-held GP port that is used for serial communication is indicated as "GP3000 (COM1)" in the Device/PLC connection manual.
- Cable length differs depending on the External Device. Communicable cable length includes the length of the GP3000H Direct-connect cable.

- Transposing from Device/PLC connection manual

Connection cable diagrams are the same for "GP3000 (COM1)" in each Device/PLC connection manual.

When using the cable diagrams from the Device/PLC connection manual for the Hand-held GP, transpose the "Display" section with "Conversion Adapter".

- The following is an example of a cable diagram in an Device/PLC connection manual:

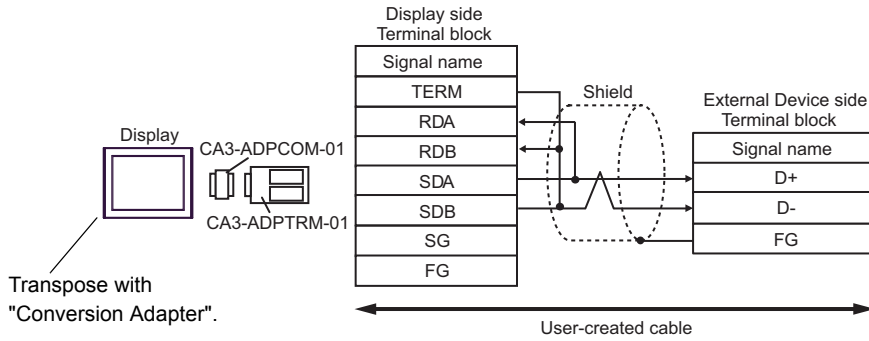

- Transposed cable diagram:

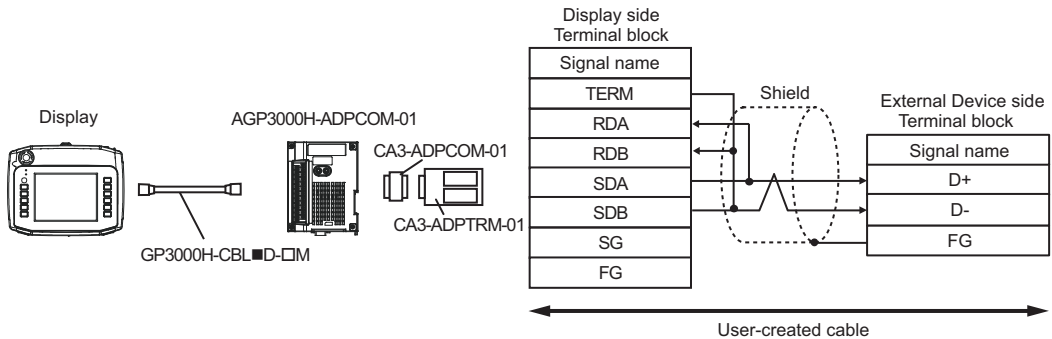

**NOTE**

- When using an Ethernet, the cable diagram is not indicated in the Device/PLC connection manual. Connect a HUB to the conversion adapter's Ethernet connector (RJ-45).



### 3.2 Configuration 2

When using the GP3000H Direct-connect cable (GP3000H-CBL■-□M)

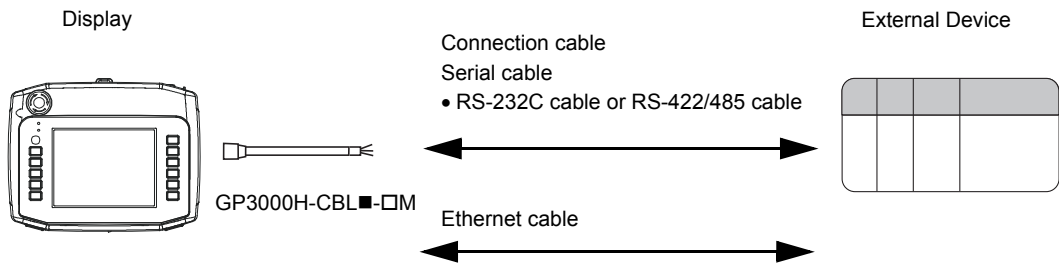

**IMPORTANT**

- Connection cable differs depending on the External Device in use. Check with the Device/PLC connection manual that corresponds to the External Device in use for the content and usage. The Hand-held GP port that is used for serial communication is indicated as "GP3000 (COM1)" in the Device/PLC connection manual.
- Cable length differs depending on the External Device. Communicable cable length includes the length of the GP3000H Direct-connect cable.

• Cable Color and Identification Marks for GP3000H Direct-connect Cable

The connection device side of the GP3000H Direct-connect cable requires trimming. When you trim the cable, check the cable color and an identification to identify the signal type.

**NOTE**

- Keep unused cables from contacting other cables or connector cases.

<RS-232C communication>

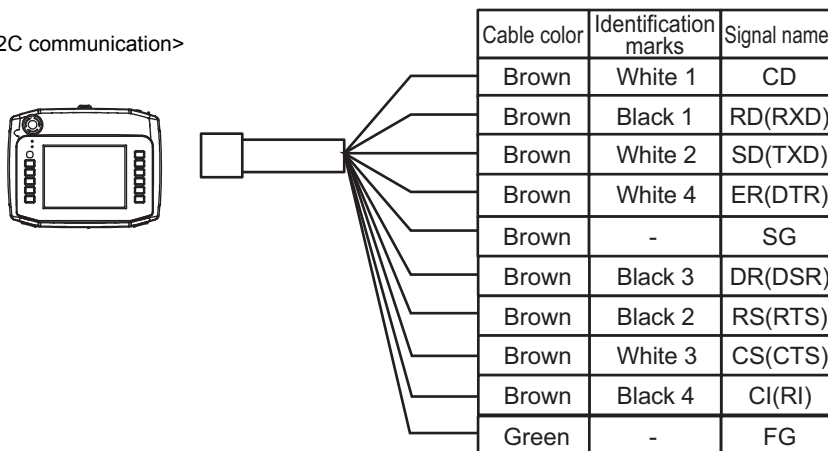

Example of cable image

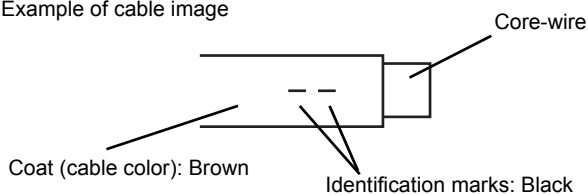

In the example above, the cable color is brown, and the identification mark shows two black lines, which means RS (RTS).

&lt;RS-422/485 communication&gt;

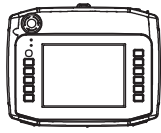

Cable color	Identification marks	Signal name
Brown	White 1	RDA
Brown	Black 1	RDB
Brown	White 2	SDA
Brown	Black 2	SDB
Brown	-	SG
Brown	White 4	ERA
Brown	White 3	CSA
Brown	Black 4	ERB
Brown	Black 3	CSB
Green	-	FG

Example of cable image

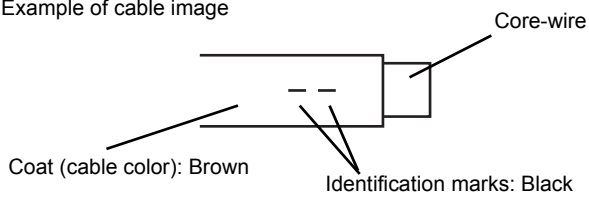

In the example above, the cable color is brown, and the identification mark shows two black lines, which means SDB.

&lt;Ethernet communication&gt;

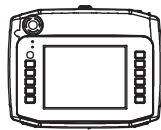

Cable color	Identification marks	Signal name
Blue	-	TX+
White	-	TX-
Brown	-	RX+
Gray	-	RX-

Use an Ethernet connector (RJ-45) for Ethernet communication.

- Transposing from Device/PLC connection manual

Connection cable diagrams are the same for "GP3000 (COM1)" in each Device/PLC connection manual.

Alternatively GP3000H Direct-connect cable (without connector) can be transposed with the cable diagram that uses only the user-created cable.

When using the cable diagrams from the Device/PLC connection manual for the Hand-held GP, transpose the "Display" section with "GP3000H Direct-connect cable".

- The following is an example of a cable diagram in an Device/PLC connection manual:

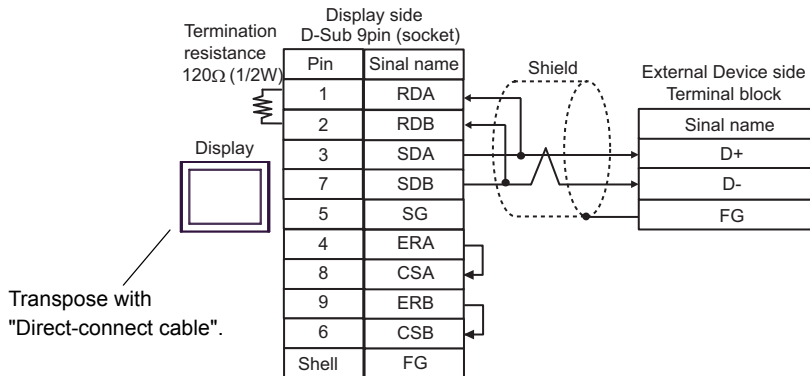

- Transposed cable diagram:

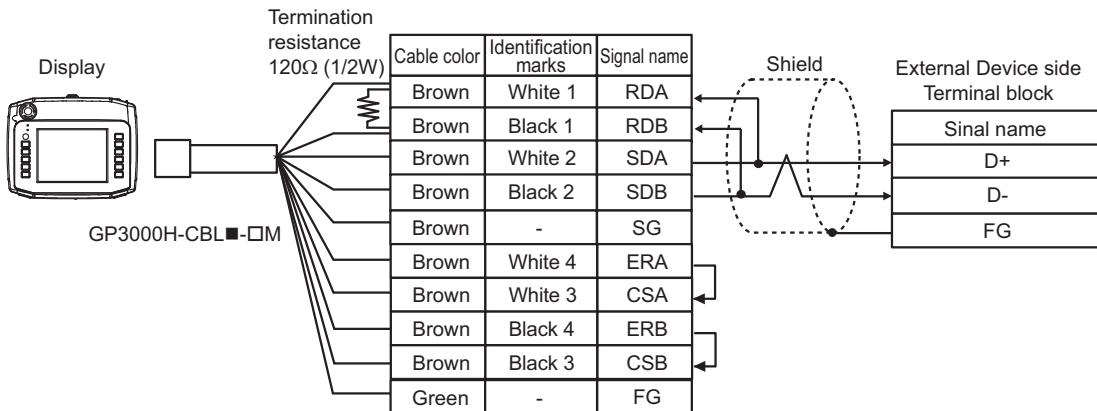

**NOTE** • When using an Ethernet, the cable diagram is not indicated in the Device/PLC connection manual. Connect a HUB to the GP3000H Direct-connect cable's Ethernet connector (RJ-45).

### 3.3 Configuration 3

When using the GP3000H Direct-connect cables (with connectors) (GP3000H-CBL■D-□M) and GP3000H Conversion Adapters (AGP3000H-ADPCOM-01) for the multilink connect

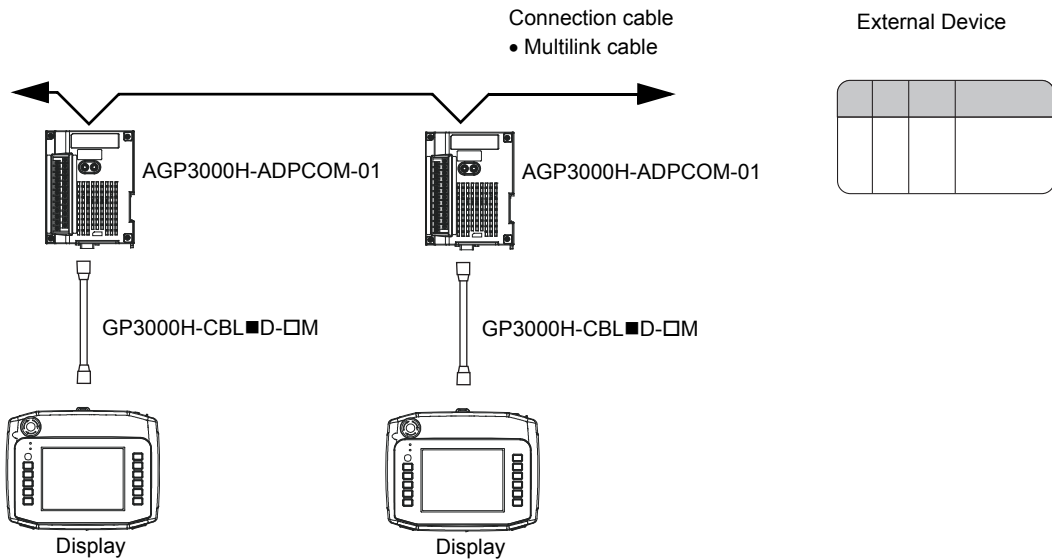

#### IMPORTANT

- Connection cable differs depending on the External Device in use. Check with the Device/PLC connection manual that corresponds to the External Device in use for the content and usage. The Hand-held GP port that is used for serial communication is indicated as "GP3000 (COM1)" in the Device/PLC connection manual.
- Cable length differs depending on the External Device. Communicable cable length includes the length of the GP3000H Direct-connect cable.
- Refer to "Serial Multilink" at the front of the GP-Pro EX Device/PLC connection manual, and confirm the driver compliant with the multilink connection.
- For the multilink connection settings, refer to the "Serial Multilink Guide" from "Serial Multilink".

- Transposing from Device/PLC connection manual

Connection cable diagrams are the same for "GP3000 (COM1)" in each Device/PLC connection manual.

When using the cable diagrams from the Device/PLC connection manual for the Hand-held GP, transpose the "Display" section with "Conversion Adapter".

- The following is an example of a cable diagram in an Device/PLC connection manual:

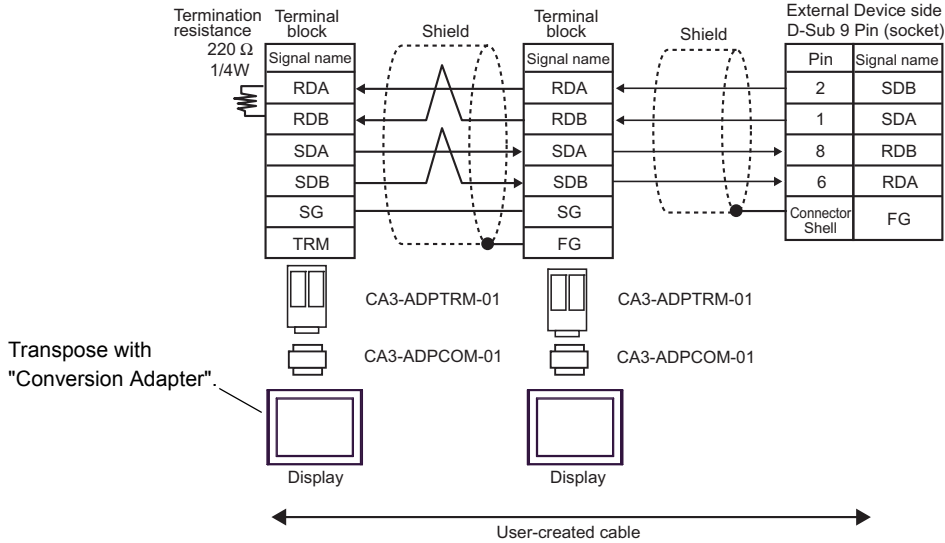

- Transposed cable diagram:

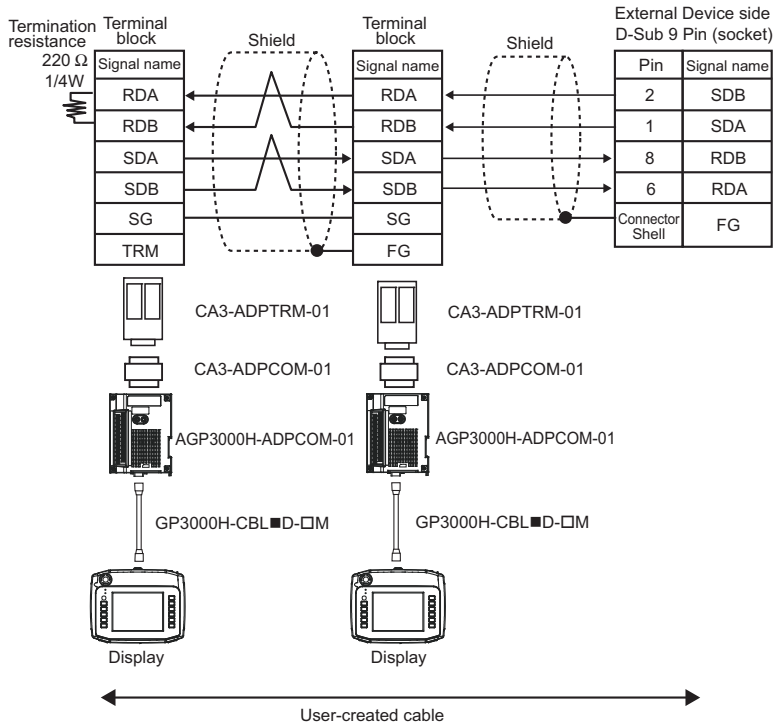

### 3.4 Configuration 4

When using the GP3000H Direct-connect cables (without connectors) (GP3000H-CBL■D-□M) for the multilink connection

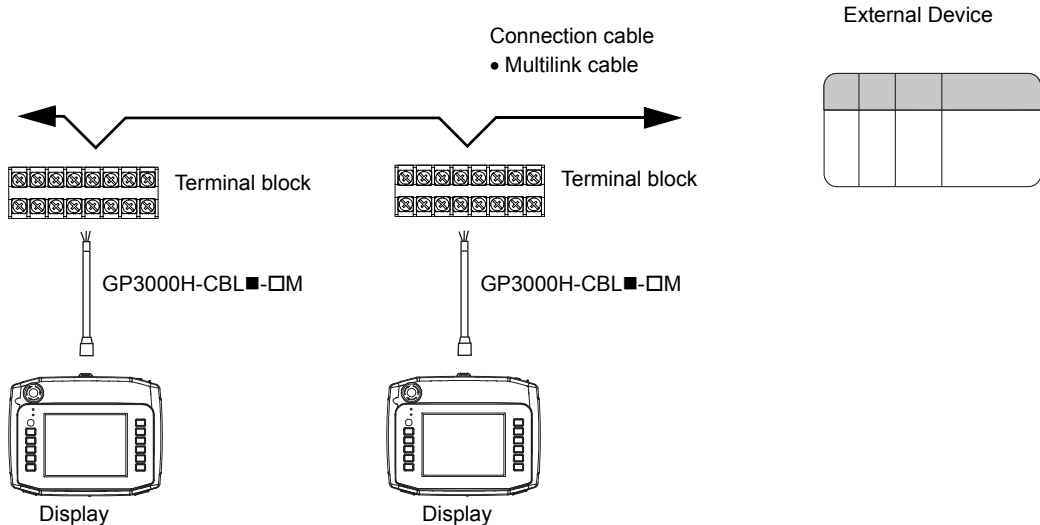

#### IMPORTANT

- Connection cable differs depending on the External Device in use. Check with the Device/PLC connection manual that corresponds to the External Device in use for the content and usage. The Hand-held GP port that is used for serial communication is indicated as "GP3000 (COM1)" in the Device/PLC connection manual.
- Cable length differs depending on the External Device. Communicable cable length includes the length of the GP3000H Direct-connect cable.
- Refer to "Serial Multilink" at the front of the GP-Pro EX Device/PLC connection manual, and confirm the driver compliant with the multilink connection.
- For the multilink connection settings, refer to the "Serial Multilink Guide" from "Serial Multilink".

- Cable Color and Identification Marks for GP3000H Direct-connect Cable

The External Device side of the GP3000H Direct-connect cable requires trimming. When you trim the cable, check the cable color and an identification to identify the signal type.

**NOTE**

- Keep unused cables from contacting other cables or connector cases.

<RS-422/485 communication>

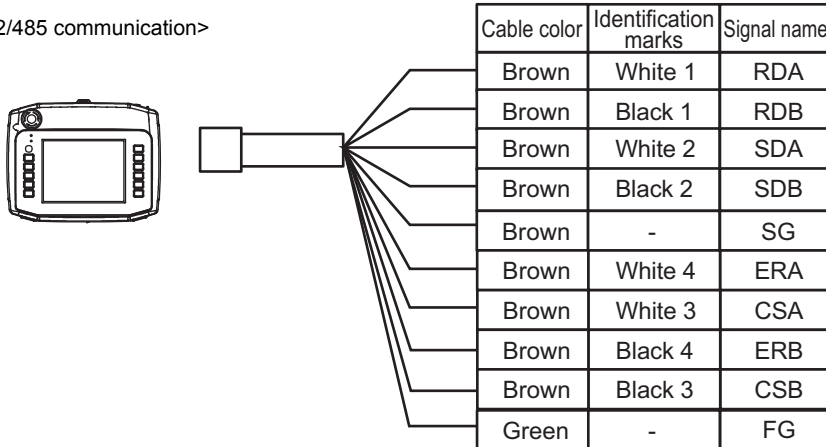

Example of cable image

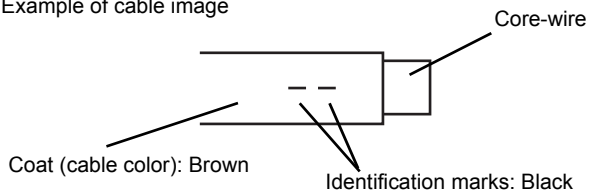

In the example above, the cable color is brown, and the identification mark shows two black lines, which means SDB.

- Transposing from Device/PLC connection manual

Connection cable diagrams are the same for "GP3000 (COM1)" in each Device/PLC connection manual. GP3000H Direct-connect cable (without connector) is connected with External Device by using terminal block. Alternatively GP3000H Direct-connect cable (without connector) can be transposed with the cable diagram that uses only the user-created cable.

When using the cable diagrams from the Device/PLC connection manual for the Hand-held GP, transpose the "Display" section with "GP3000H Direct-connect cable".

- The following is a multilink connection example of a cable diagram in an Device/PLC connection manual:

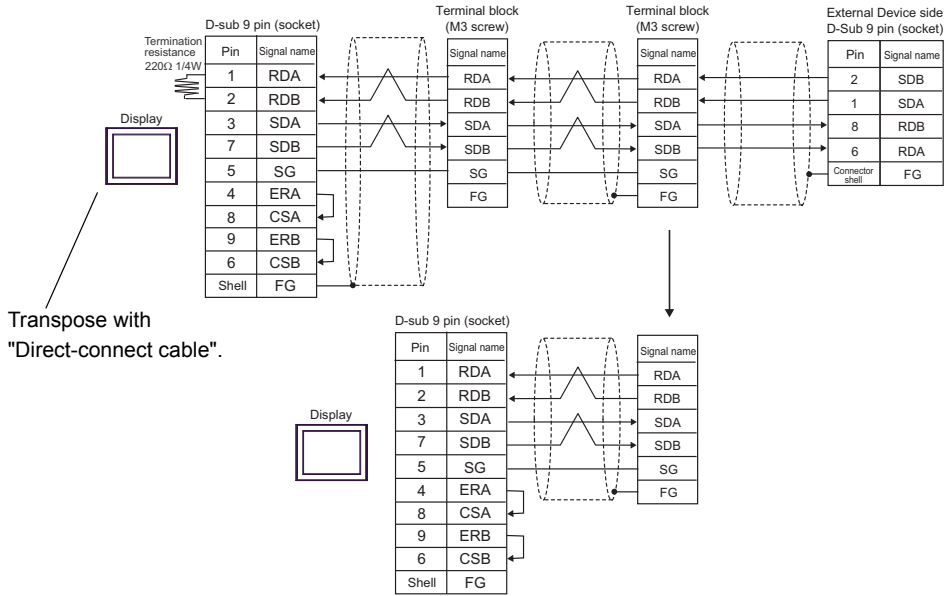

- Transposed cable diagram:

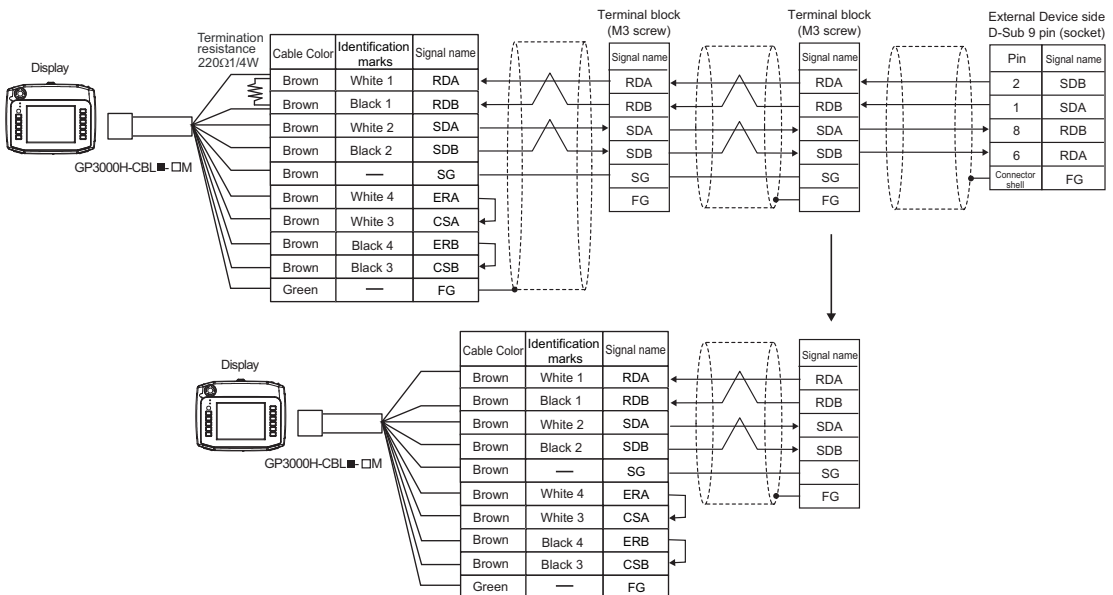



### 3.5 Configuration 5

When using the GP3000H Soft-type Cable for GP2000H Conversion Adapter <RS-232C> (with connector) (GP3000H-CBLS232-□M) and GP2000H Series RS-232C Conversion Adapter (GP2000H-AP232)

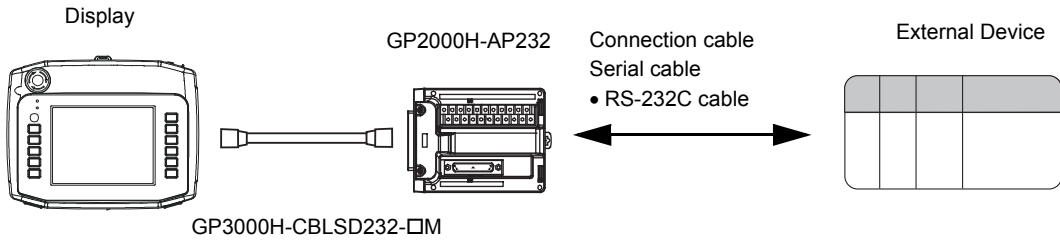

#### IMPORTANT

- Connection cable differs depending on the External Device in use. Check with the Device/PLC connection manual that corresponds to the External Device in use for the content and usage. The GP3000H series port that is used for serial communication is indicated as "GP3000 (COM1)" in the Device/PLC connection manual.
  - Cable length differs depending on the External Device. Communicable cable length includes the length of the GP3000H Direct-connect cable.
- 
- Pin number of the GP2000H Series RS-232C Conversion Adapter  
Connection port of the GP2000H Series RS-232C Conversion Adapter is D-Sub25 pin (socket). "GP3000 (COM1)" indicated in the Device/PLC connection manual is D-Sub9 pin, so the pin number needs to be transposed.

Pin-out indicated in the Device/ PLC connection manual		Pin-out of GP2000H Series RS-232C Conversion Adapter	
GP3000 (COM1) side D-Sub 9 pin (socket)		GP2000-AP232 side D-Sub 25 pin (plug)	
Pin	Signal name	Pin	Signal name
1	CD	8	CD
2	RD (RXD)	3	RD (RXD)
3	SD (TXD)	2	SD (TXD)
4	ER (DTR)	20	ER (DTR)
5	SG	7	SG
6	DR (DSR)	-	-
7	RS (RTS)	4	RS (RTS)
8	CS (CTS)	5	CS (CTS)
9	CI/VCC	14	CI/VCC
Shell	FG	1	FG

Transpose the Display pin number (D-Sub9 pin) with the GP2000H-AP232 pin number (D-Sub25 pin).

#### NOTE

- There is no "DR(DSR)" for the GP2000H Series RS-232C Conversion Adapter.
- When the system has been already constructed using the GP2000H Series RS-232C Conversion Adapter, the existing cable can be used as the connection cable.
- When using a system constructed by GP-PRO/PBIII for Windows, the External Device name is changed. Refer to the GP-Pro EX Reference Manual for details.

- Transposing from Device/PLC connection manual

The connection cable diagram is the same for connect the user-created cable to "GP3000 (COM1)" in each Device/PLC connection manual.

When using the cable diagrams from the Device/PLC connection manual for the GP3000H series, transpose the "Display" section with "Conversion Adapter".

- The following is an example of a cable diagram in an Device/PLC connection manual:

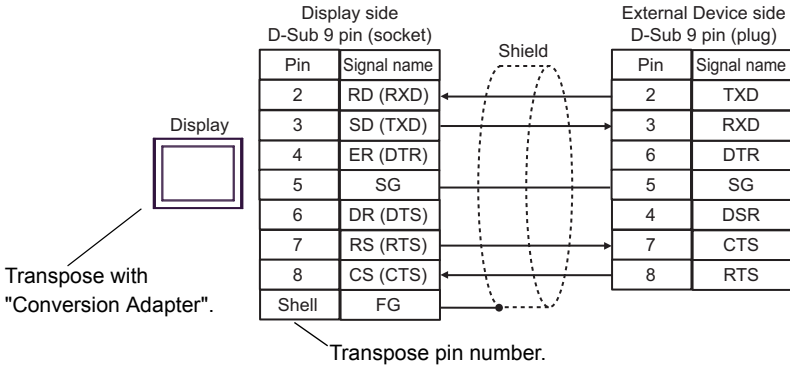

- Transposed cable diagram:

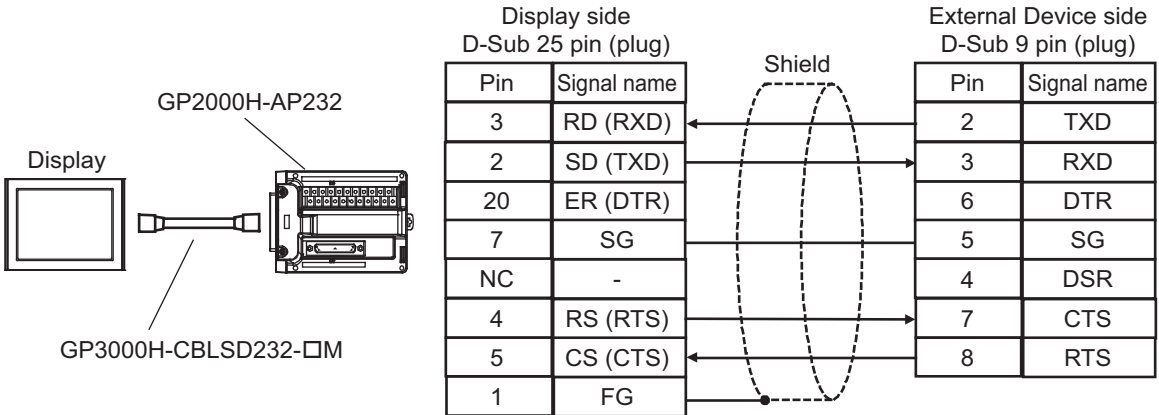

### 3.6 Configuration 6

When using the GP3000H Soft-type Cable for GP2000H Conversion Adapter <RS-232C> (with connector) (GP3000H-CBLS232-□M), GP2000H Series RS-232C Conversion Adapter (GP2000H-AP232) and RS-232C Cable (GP410-IS00-O)

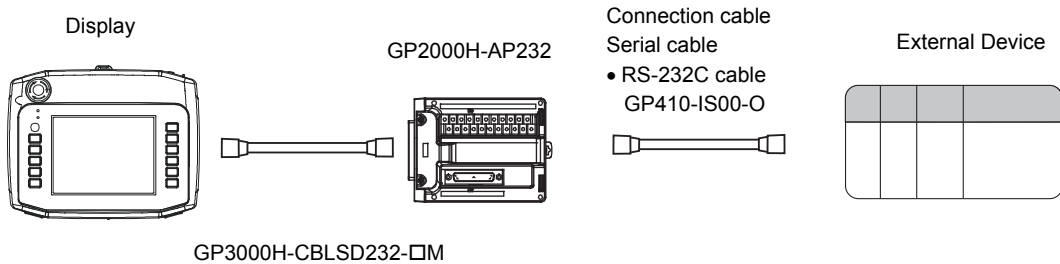

#### **IMPORTANT**

- Connection cable differs depending on the External Device in use. Check with the Device/PLC connection manual that corresponds to the External Device in use for the content and usage. The GP3000H series port that is used for serial communication is indicated as "GP3000 (COM1)" in the Device/PLC connection manual.
- Cable length differs depending on the External Device. Communicable cable length includes the length of the GP3000H Direct-connect cable.

- Transposing from Device/PLC connection manual

The connection cable diagram is the same for connect the RS-232C Cable (CA3-CBL232/5M-01) by Pro-face to "GP3000 (COM1)" in each Device/PLC connection manual.

When using the cable diagrams from the Device/PLC connection manual for the GP3000H series, transpose the "Display" section with "Conversion Adapter".

- The following is an example of a cable diagram in an Device/PLC connection manual:

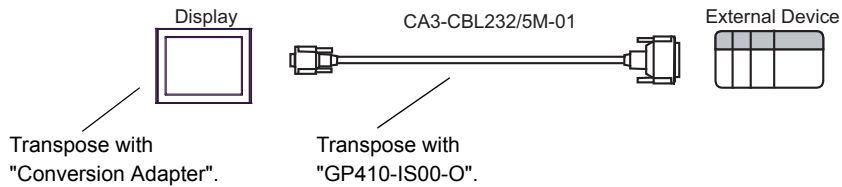

- Transposed cable diagram:

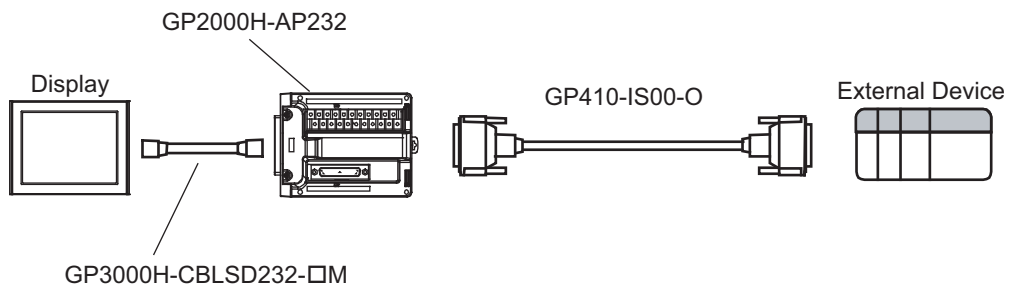

### 3.7 Configuration 7

When using the GP3000H Soft-type Cable for GP2000H Conversion Adapter <RS-422> (with connector) (GP3000H-CBLS422-□M) and GP2000H Series RS-422 Conversion Adapter (GP2000H-AP422)

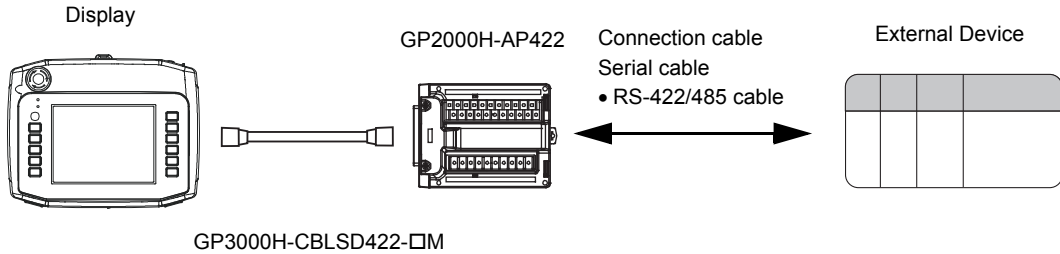

#### IMPORTANT

- Connection cable differs depending on the External Device in use. Check with the Device/PLC connection manual that corresponds to the External Device in use for the content and usage. The GP3000H series port that is used for serial communication is indicated as "GP3000 (COM1)" in the Device/PLC connection manual.
  - Cable length differs depending on the External Device. Communicable cable length includes the length of the GP3000H Direct-connect cable.
- 
- Pin number of the GP2000H Series RS-422 Conversion Adapter  
Connection port of the GP2000H Series RS-422 Conversion Adapter is 10 poles terminal block. "GP3000 (COM1)" indicated in the Device/PLC connection manual is D-Sub9 pin, so the pin number needs to be transposed.

Pin-out indicated in the Device/  
PLC connection manual

GP3000 (COM1) side  
D-Sub 9 pin (socket)

Pin	Signal name
1	RDA
2	RDB
3	SDA
7	SDB
5	SG
4	ERA
8	CSA
9	ERB
6	CSB
Shell	FG

Pin-out of GP2000H Series RS-422  
Conversion Adapter

GP2000-AP422 side  
10 poles terminal block

Pin	Signal name
6	RDA
5	RDB
4	SDA
3	SDB
2	SG
8	ERA
7	CSA
10	ERB
9	CSB
1	FG

Transpose the Display pin number (D-Sub9 pin) with the GP200H-AP422 pin number (10 poles terminal block).

#### NOTE

- When the system has been already constructed using the GP2000H Series RS-422 Conversion Adapter, the existing cable can be used as the connection cable.
- When using a system constructed by GP-PRO/PBIII for Windows, the External Device name is changed. Refer to the GP-Pro EX Reference Manual for details.

- Transposing from Device/PLC connection manual

The connection cable diagram is the same for connect the user-created cable to "GP3000 (COM1)" in each Device/PLC connection manual.

When using the cable diagrams from the Device/PLC connection manual for the GP3000H series, transpose the "Display" section with "Conversion Adapter".

- The following is an example of a cable diagram in an Device/PLC connection manual:

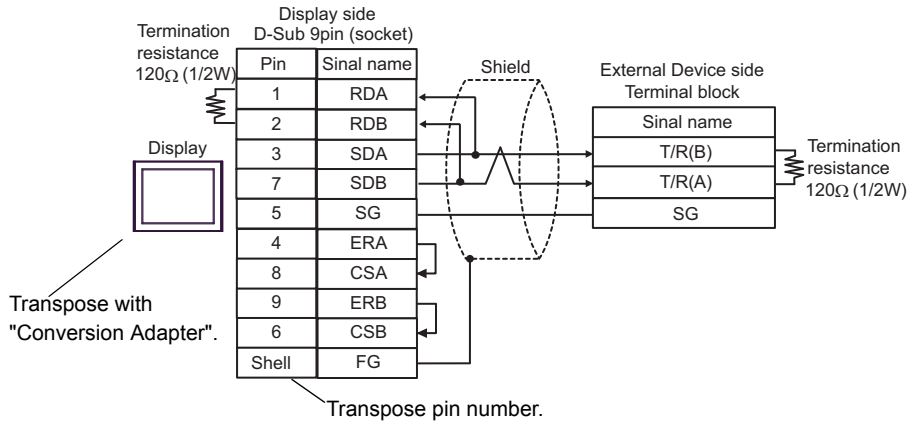

- Transposed cable diagram:

