



Temperature Controller CompoWay/F Driver

1	System Configuration.....	3
2	Selection of External Device	6
3	Example of Communication Setting	7
4	Setup Items	17
5	Cable Diagram	22
6	Supported device	31
7	Device Code and Address Code.....	38
8	Error Messages.....	40

Introduction

This manual describes how to connect the Display and the External Device (target Temperature Controller).

In this manual, the connection procedure will be described by following the below sections:

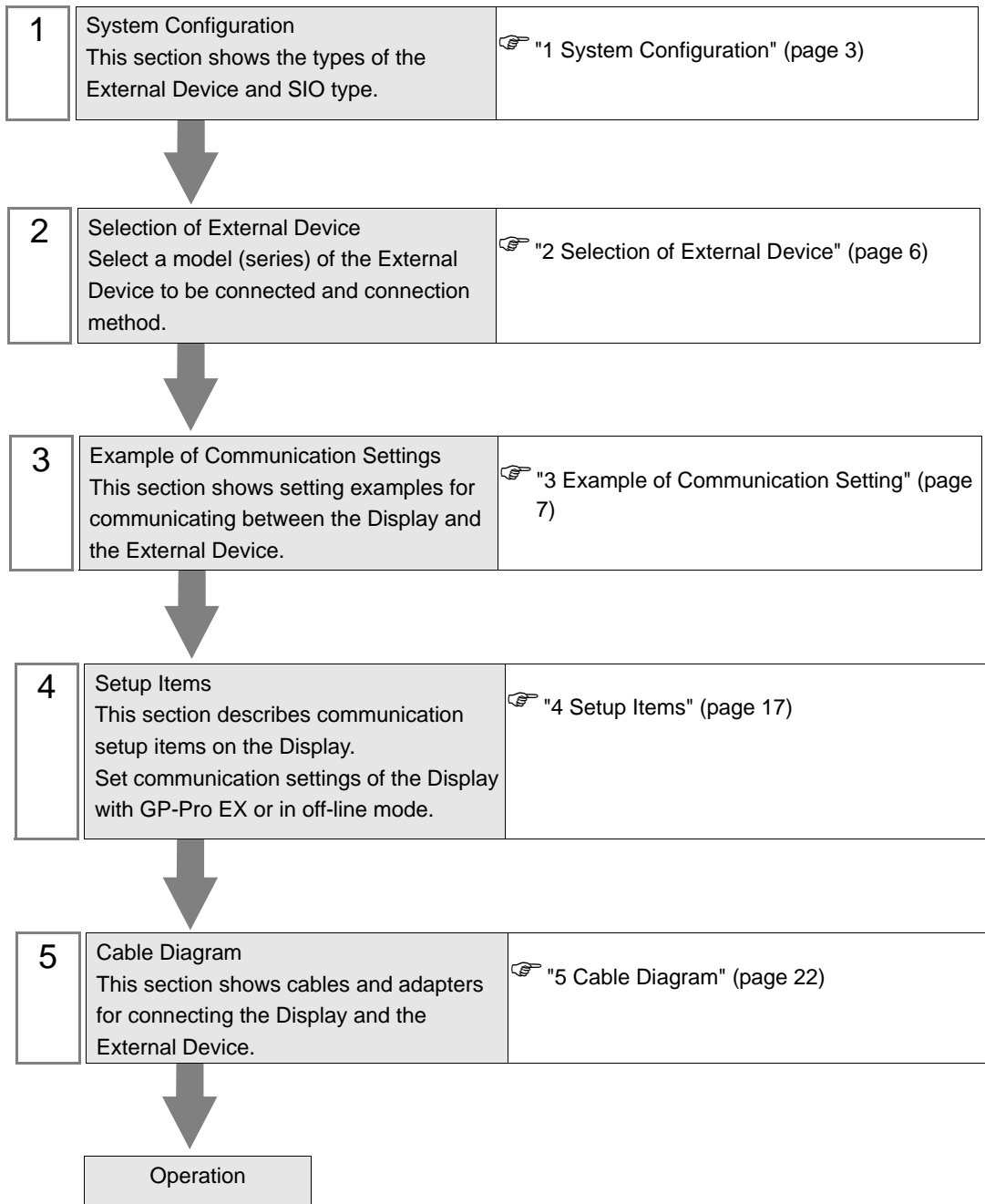

1 System Configuration

The system configuration in the case when the External Device of OMRON Corporation and the Display are connected is shown.

Series	CPU*1	Link I/F	SIO Type	Communi- cation Settings	Cable Diagram
THERMA CNEO	E5EN-□□□□□-FLK E5AN-□□□□□-FLK	Terminal block on the controller	RS232C	Setting Example 1 (page 7)	Cable Diagram 1 (page 23)
	E5EN-□□□□□-FLK E5AN-□□□□□-FLK E5CN-□□□□□-FLK E5GN-□□□□□-FLK		RS485 (2wire)	Setting Example 2 (page 9)	Cable Diagram 2 (page 24)
THERMA CR	E5AR-□□□□□□□□□-FLK E5ER-□□□□□□□□□-FLK	Terminal block on the controller	RS485 (2wire)	Setting Example 3 (page 11)	Cable Diagram 2 (page 24)
In-Panel NEO	E5ZN-□□□□□□□-FLK	Terminal block on the controller	RS485 (2wire) 1:1	Setting Example 4 (page 13)	Cable Diagram 2 (page 24)
			RS485 (2wire) 1:n	Setting Example 5 (page 15)	

*1 Model number of the controller "□" varies depending on the function specification of each controller.

■ COM Port of IPC

When connecting IPC with External Device, the COM port which can be used changes with series and SIO type. Please refer to the manual of IPC for details.

Usable port

Series	Usable port		
	RS-232C	RS-422/485(4 wire)	RS-422/485(2 wire)
PS-2000B	COM1 ^{*1} , COM2, COM3 ^{*1} , COM4	-	-
PS-3450A, PS-3451A	COM1, COM2 ^{*1*2}	COM2 ^{*1*2}	COM2 ^{*1*2}
PS-3650A, PS-3651A	COM1 ^{*1}	-	-
PS-3700A (Pentium®4-M) PS-3710A	COM1 ^{*1} , COM2 ^{*1} , COM3 ^{*2} , COM4	COM3 ^{*2}	COM3 ^{*2}
PS-3711A	COM1 ^{*1} , COM2 ^{*2}	COM2 ^{*2}	COM2 ^{*2}
PL-3000B	COM1 ^{*1*2} , COM2 ^{*1} , COM3, COM4	COM1 ^{*1*2}	COM1 ^{*1*2}

*1 The RI/5V can be switched. Please switch with the change switch of IPC.

*2 It is necessary to set up the SIO type with the Dip switch. Please set up as follows according to SIO type to be used.

Dip switch setting: RS-232C

Dip switch	Setting	Description
1	OFF ^{*1}	Reserve (always OFF)
2	OFF	SIO type: RS-232C
3	OFF	
4	OFF	Output mode of SD (TXD) data: Always output
5	OFF	Terminal resistance (220Ω) insertion to SD (TXD): None
6	OFF	Terminal resistance (220Ω) insertion to RD (RXD): None
7	OFF	Short-circuit of SDA (TXA) and RDA (RXA): Does not Exist
8	OFF	Short-circuit of SDB (TXB) and RDB (RXB): Does not Exist
9	OFF	RS (RTS) Auto control mode: Disable
10	OFF	

*1 It is necessary to turn ON the set value, only when using PS-3450A and PS-3451A.

Dip switch setting: RS-422/485 (4 wire)

Dip switch	Setting	Description
1	OFF	Reserve (always OFF)
2	ON	SIO type: RS-422/485
3	ON	
4	OFF	Output mode of SD (TXD) data: Always output
5	OFF	Terminal resistance (220Ω) insertion to SD (TXD): None
6	OFF	Terminal resistance (220Ω) insertion to RD (RXD): None
7	OFF	Short-circuit of SDA (TXA) and RDA (RXA): Does not Exist
8	OFF	Short-circuit of SDB (TXB) and RDB (RXB): Does not Exist
9	OFF	RS (RTS) Auto control mode: Disable
10	OFF	

Dip switch setting: RS-422/485 (2 wire)

Dip switch	Setting	Description
1	OFF	Reserve (always OFF)
2	ON	SIO type: RS-422/485
3	ON	
4	OFF	Output mode of SD (TXD) data: Always output
5	OFF	Terminal resistance (220Ω) insertion to SD (TXD): None
6	OFF	Terminal resistance (220Ω) insertion to RD (RXD): None
7	ON	Short-circuit of SDA (TXA) and RDA (RXA): Exist
8	ON	Short-circuit of SDB (TXB) and RDB (RXB): Exist
9	ON	RS (RTS) Auto control mode: Enable
10	ON	

2 Selection of External Device

Select the External Device to be connected to the Display.

Setup Items	Setup Description
Maker	Select the maker of the External Device to be connected. Select "OMRON Corporation".
Series	Select a model (series) of the External Device to be connected and connection method. Select "Temperature Controller CompoWay/F". Check the External Device which can be connected in "Temperature Controller CompoWay/F" in system configuration. ☞ "1 System Configuration" (page 3)
Use System Area	Cannot be set in this driver.
Port	Select the Display port to be connected to the External Device.

3 Example of Communication Setting

Examples of communication settings of the Display and the External Device, recommended by Digital Electronics Corp., are shown.

3.1 Setting Example 1

■ Setting of GP-Pro EX

◆ Communication Settings

To display the setting screen, select [Device/PLC Settings] from [System setting window] in workspace.

Device/PLC 1

Summary [Change Device/PLC](#)

Maker Driver Port

Text Data Mode [Change](#)

Communication Settings

SID Type RS232C RS422/485(2wire) RS422/485(4wire)
 Speed
 Data Length 7 8
 Parity NONE EVEN ODD
 Stop Bit 1 2
 Flow Control NONE ER(DTR/CTS) XON/XOFF
 Timeout (sec)
 Retry
 Wait To Send (ms)

RI / VCC RI VCC
 In the case of RS232C, you can select the 9th pin to RI (Input) or VCC (5V Power Supply). If you use the Digital's RS232C Isolation Unit, please select it to VCC.

Device-Specific Settings

Allowable No. of Device/PLCs 16 Unit(s)

No.	Device Name	Settings
1	PLC1	Series=E5A/E/C/GN_Unit No.=1

◆ Device Setting

To display the setting screen, click  ([Setting]) of the External Device you want to set from [Device-Specific Settings] of [Device/PLC Settings].



NOTE • Set the HOST link unit No. for "Unit No."

■ Settings of External Device

Use the level key, mode key, down key and up key in front of the Temperature Controller for communication settings of the External Device.

Please refer to the manual of the Temperature Controller for more details.

◆ Procedure

1. Press and hold the level key (3 minutes or more) to transfer from the operation level to the default level.
2. Press the level key again to transfer from the default level to the communication setting level.
3. Press the mode key to select the parameter.
4. Press the down/up keys to change the setting.
5. Press and hold the level key to transfer to the operation level.

◆ Setting Value

PSEL	CWF
U-NO	1
BPS	9.6
LEN	7
SBIT	2
PRTY	EVEN
SDWT	2

NOTE • Parameters to be set vary depending on the Temperature Controller. Please refer to the manual of the Temperature Controller for more details.

- Set Wait to Send to 2ms or more. Adjust Wait to Send according to the communication status.

3.2 Setting Example 2

■ Setting of GP-Pro EX

◆ Communication Settings

To display the setting screen, select [Device/PLC Settings] from [System setting window] in workspace.

Device/PLC 1

Summary [Change Device/PLC](#)

Maker Driver Port

Text Data Mode [Change](#)

Communication Settings

SID Type RS232C RS422/485(2wire) RS422/485(4wire)
 Speed
 Data Length 7 8
 Parity NONE EVEN ODD
 Stop Bit 1 2
 Flow Control NONE ER(DTR/CTS) XON/XOFF
 Timeout (sec)
 Retry
 Wait To Send (ms)

RI / VCC RI VCC
 In the case of RS232C, you can select the 9th pin to RI (Input) or VCC (5V Power Supply). If you use the Digital's RS232C Isolation Unit, please select it to VCC.

Device-Specific Settings

Allowable No. of Device/PLCs 16 Unit(s)

No.	Device Name	Settings
1	PLC1	Series=E5A/E/C/GN,Unit No.=1

◆ Device Setting

To display the setting screen, click  ([Setting]) of the External Device you want to set from [Device-Specific Settings] of [Device/PLC Settings].

When you connect multiple External Device, click  from [Device-Specific Settings] of [Device/PLC Settings] to add another External Device.

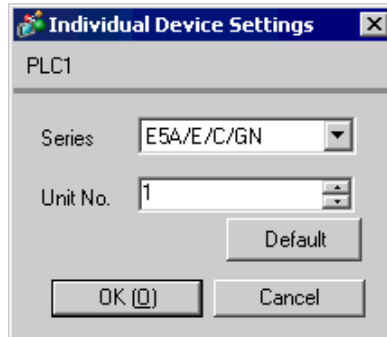

NOTE • Set the HOST link unit No. for "Unit No.".

■ Settings of External Device

Use the level key, mode key, down key and up key in front of the Temperature Controller for communication settings of the External Device.

Please refer to the manual of the Temperature Controller for more details.

◆ Procedure

1. Press and hold the level key (3 minutes or more) to transfer from the operation level to the default level.
2. Press the level key again to transfer from the default level to the communication setting level.
3. Press the mode key to select the parameter.
4. Press the down/up keys to change the setting.
5. Press and hold the level key to transfer to the operation level.

◆ Setting Value

PSEL	CWF
U-NO	1
BPS	9.6
LEN	7
SBIT	2
PRTY	EVEN
SDWT	2

NOTE • Parameters to be set vary depending on the Temperature Controller. Please refer to the manual of the Temperature Controller for more details.

- Set Wait to Send to 2ms or more. Adjust Wait to Send according to the communication status.

3.3 Setting Example 3

■ Setting of GP-Pro EX

◆ Communication Settings

To display the setting screen, select [Device/PLC Settings] from [System setting window] in workspace.

Device/PLC 1

Summary [Change Device/PLC](#)

Maker Driver Port

Text Data Mode [Change](#)

Communication Settings

SID Type RS232C RS422/485(2wire) RS422/485(4wire)
 Speed
 Data Length 7 8
 Parity NONE EVEN ODD
 Stop Bit 1 2
 Flow Control NONE ER(DTR/CTS) XON/XOFF
 Timeout (sec)
 Retry
 Wait To Send (ms)

RI / VCC RI VCC
 In the case of RS232C, you can select the 9th pin to RI (Input) or VCC (5V Power Supply). If you use the Digital's RS232C Isolation Unit, please select it to VCC.

Device-Specific Settings

Allowable No. of Device/PLCs 16 Unit(s)

No.	Device Name	Settings
1	PLC1	Series=E5A/ER,Unit No.=1

◆ Device Setting

To display the setting screen, click  ([Setting]) of the External Device you want to set from [Device-Specific Settings] of [Device/PLC Settings].

When you connect multiple External Device, click  from [Device-Specific Settings] of [Device/PLC Settings] to add another External Device.

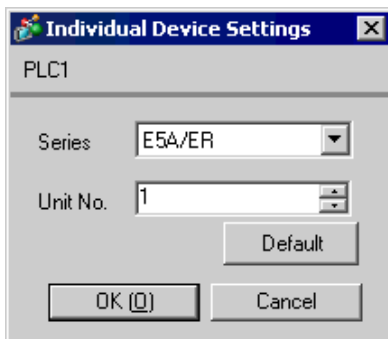

NOTE • Set the HOST link unit No. for "Unit No.".

■ Settings of External Device

Use the level key, mode key, down key and up key in front of the Temperature Controller for communication settings of the External Device.

Please refer to the manual of the Temperature Controller for more details.

◆ Procedure

1. Press and hold the level key (3 minutes or more) to transfer from the operation level to the default level.
2. Press the level key again to transfer from the default level to the communication setting level.
3. Press the mode key to select the parameter.
4. Press the down/up keys to change the setting.
5. Press and hold the level key to transfer to the operation level.

◆ Setting Value

PSEL	CWF
U-NO	1
BPS	9.6
LEN	7
SBIT	2
PRTY	EVEN
SDWT	5

NOTE • Parameters to be set vary depending on the Temperature Controller. Please refer to the manual of the Temperature Controller for more details.

- Set Wait to Send to 5ms or more. Finely adjust Wait to Send according to the communication status.

3.4 Setting Example 4

■ Setting of GP-Pro EX

◆ Communication Settings

To display the setting screen, select [Device/PLC Settings] from [System setting window] in workspace.

Device/PLC 1

Summary [Change Device/PLC](#)

Maker Driver Port

Text Data Mode [Change](#)

Communication Settings

SID Type RS232C RS422/485(2wire) RS422/485(4wire)

Speed

Data Length 7 8

Parity NONE EVEN ODD

Stop Bit 1 2

Flow Control NONE ER(DTR/CTS) XON/XOFF

Timeout (sec)

Retry

Wait To Send (ms)

RI / VCC RI VCC

In the case of RS232C, you can select the 9th pin to RI (Input) or VCC (5V Power Supply). If you use the Digital's RS232C Isolation Unit, please select it to VCC.

Device-Specific Settings

Allowable No. of Device/PLCs 16 Unit(s)

No.	Device Name	Settings
1	PLC1	Series=E5ZN,Unit No.=1

◆ Device Setting

To display the setting screen, click  ([Setting]) of the External Device you want to set from [Device-Specific Settings] of [Device/PLC Settings].

When you connect multiple External Device, click  from [Device-Specific Settings] of [Device/PLC Settings] to add another External Device.

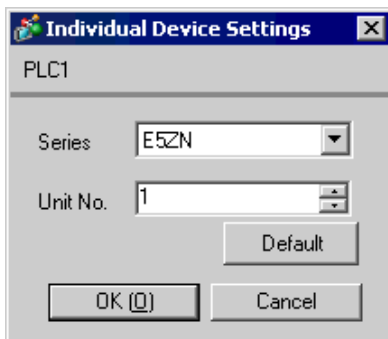

NOTE • Set the HOST link unit No. for "Unit No.".

■ Settings of External Device

Use the level key, mode key, down key and up key in front of the Temperature Controller for communication settings of the External Device.

Please refer to the manual of the Temperature Controller for more details.

◆ Procedure

1. Use the rotary switch in front of the Temperature Controller to set Unit No. (UNIT) and Speed (BPS).
2. Press and hold the level key (3 minutes or more) in front of the Display to transfer from the operation level to the default level.
3. Press the level key several times to transfer from the default level to the communication setting level.
4. Press the mode key to select the parameter.
5. Press the down/up keys to change the setting.
6. Press and hold the level key to transfer to the operation level.

◆ Setting Value

- Setting of the rotary switch of the Temperature Controller

UNIT	1
BPS	1

- Setting of the display exclusive for the Temperature Controller

LEN	7
SBIT	2
PRTY	EVEN
SDWT	5

NOTE • Parameters to be set vary depending on the Temperature Controller. Please refer to the manual of the Temperature Controller for more details.

- Set Wait to Send to 5ms or more. Finely adjust Wait to Send according to the communication status.

3.5 Setting Example 5

■ Setting of GP-Pro EX

◆ Communication Settings

To display the setting screen, select [Device/PLC Settings] from [System setting window] in workspace.

Device/PLC 1

Summary [Change Device/PLC](#)

Maker Driver Port

Text Data Mode [Change](#)

Communication Settings

SID Type RS232C RS422/485(2wire) RS422/485(4wire)

Speed

Data Length 7 8

Parity NONE EVEN ODD

Stop Bit 1 2

Flow Control NONE ER(DTR/CTS) XON/XOFF

Timeout (sec)

Retry

Wait To Send (ms)

RI / VCC RI VCC

In the case of RS232C, you can select the 9th pin to RI (Input) or VCC (5V Power Supply). If you use the Digital's RS232C Isolation Unit, please select it to VCC.

Device-Specific Settings

Allowable No. of Device/PLCs 16 Unit(s)

No.	Device Name	Settings
1	PLC1	Series=E5ZN,Unit No.=1

◆ Device Setting

To display the setting screen, click  ([Setting]) of the External Device you want to set from [Device-Specific Settings] of [Device/PLC Settings].

When you connect multiple External Device, click  from [Device-Specific Settings] of [Device/PLC Settings] to add another External Device.



NOTE • Set the HOST link unit No. for "Unit No.".

■ Settings of External Device

Use the level key, mode key, down key and up key in front of the Temperature Controller for communication settings of the External Device.

Please refer to the manual of the Temperature Controller for more details.

◆ Procedure

1. Use the rotary switch in front of the Temperature Controller to set Unit No. (UNIT) and Speed (BPS).
2. Press and hold the level key (3 minutes or more) in front of the Display to transfer from the operation level to the default level.
3. Press the level key several times to transfer from the default level to the communication setting level.
4. Press the mode key to select the parameter.
5. Press the down/up keys to change the setting.
6. Press and hold the level key to transfer to the operation level.

◆ Setting Value

- Setting of the rotary switch of the Temperature Controller

UNIT	1
BPS	1

- Setting of the display exclusive for the Temperature Controller

LEN	7
SBIT	2
PRTY	EVEN
SDWT	20

NOTE • Parameters to be set vary depending on the Temperature Controller. Please refer to the manual of the Temperature Controller for more details.

- Set Wait to Send to 20ms or more. Finely adjust Wait to Send according to the communication status.

4 Setup Items

Set communication settings of the Display with GP-Pro Ex or in off-line mode of the Display.

The setting of each parameter must be identical to that of External Device.

 "3 Example of Communication Setting" (page 7)

4.1 Setup Items in GP-Pro EX

■ Communication Settings

To display the setting screen, select [Device/PLC Settings] from [System setting window] in workspace.

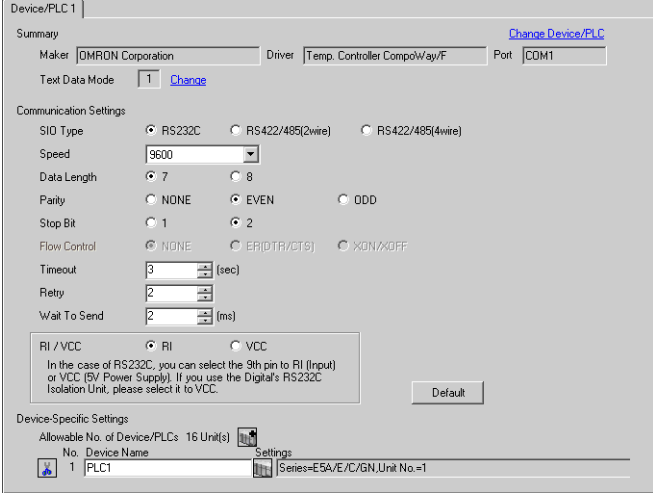

Device/PLC1

Summary [Change Device/PLC](#)

Maker: Driver: Port:

Text Data Mode: [Change](#)

Communication Settings

SIO Type: RS232C RS422/485(2wire) RS422/485(4wire)

Speed:

Data Length: 7 8

Parity: NONE EVEN ODD

Stop Bit: 1 2

Flow Control: NONE ER(DTR/CTS) XON/XOFF

Timeout: (sec)

Retry:

Wait To Send: (ms)

RI / VCC: RI VCC

In the case of RS232C, you can select the 9th pin to RI (Input) or VCC (5V Power Supply). If you use the Digital's RS232C Isolation Unit, please select it to VCC.

Default

Device-Specific Settings

Allowable No. of Device/PLCs: 16 Unit(s)

No. Device Name Settings:

Setup Items	Setup Description
SIO Type	Select a SIO type for communicating with an external device from "RS232C", "RS422/485 (2-wire)", and "RS422/485 (4-wire)".
Speed	Select speed (bps) between the External Device and the Display.
Data Length	Select the data length (bit) for communication. Select either "7" or "8".
Parity	Select how to check parity. Select any of "None", "Even" and "Odd".
Stop Bit	Select stop bit length. Select either "1" or "2".
Flow Control	The communication control method to prevent overflow of transmission and reception data is displayed.
Timeout	Use an integer from 1 to 127 to enter the time (s) for which the Display waits for the response from the External Device.
Retry	In case of no response from the External Device, use an integer from 0 to 255 to enter how many times the Display retransmits the command.
Wait To Send	Use an integer from 0 to 255 to enter standby time (ms) for the Display from receiving packets to transmitting next commands.
RI/VCC	You can switch RI/VCC of the 9th pin when you select RS232C for SIO type. It is necessary to change RI/5V by changeover switch of IPC when connect with IPC. Please refer to the manual of the IPC for more detail.

■ Device Setting

To display the setting screen, click  ([Setting]) of the External Device you want to set from [Device-Specific Settings] of [Device/PLC Settings].

When you connect multiple External Device, click  from [Device-Specific Settings] of [Device/PLC Settings] to add another External Device.

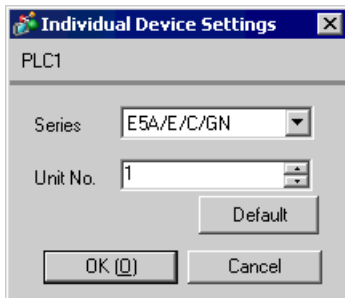

Setup Items	Setup Description
Series	Select a model of the External Device.
Unit No.	Enter the unit No. for HOST link.

4.2 Settings in Off-Line Mode

- NOTE** • Please refer to Maintenance/Troubleshooting for more information on how to enter off-line mode or about operation.
Cf. Maintenance/Troubleshooting "2.2 Offline Mode"

■ Communication Settings

To display the setting screen, touch [Device/PLC Settings] from [System setting window] in workspace. Touch the External Device you want to set from the displayed list.

Comm.	Device	Option		
Temp. Controller CompoWay/F			[COM1]	Page 1/1
SIO Type		RS422/485(2wire) ▼		
Speed		9600 ▼		
Data Length		<input checked="" type="radio"/> 7	<input type="radio"/> 8	
Parity		<input type="radio"/> NONE	<input checked="" type="radio"/> EVEN	<input type="radio"/> ODD
Stop Bit		<input type="radio"/> 1	<input checked="" type="radio"/> 2	
Flow Control		NONE		
Timeout(s)			3 ▼ ▲	
Retry			2 ▼ ▲	
Wait To Send(ms)			2 ▼ ▲	
	Exit		Back	2005/12/16 16:55:00

Setup Items	Setup Description
SIO Type	Select a SIO type for communicating with an external device from "RS232C", "RS422/485 (2-wire)", and "RS422/485 (4-wire)". IMPORTANT To make the communication settings correctly, confirm the serial interface specifications of Display unit for [SIO Type]. We cannot guarantee the operation if a communication type that the serial interface does not support is specified. For details concerning the serial interface specifications, refer to the manual for Display unit.
Speed	Select speed (bps) between the External Device and the Display.
Data Length	Select the data length (bit) for communication. Select either "7" or "8".
Parity	Select how to check parity. Select any of "None", "Even" and "Odd".
Stop Bit	Select stop bit length. Select either "1" or "2".
Flow Control	The communication control method to prevent overflow of transmission and reception data is displayed.
Timeout	Use an integer from 1 to 127 to enter the time (s) for which the Display waits for the response from the External Device.

Setup Items	Setup Description
Retry	In case of no response from the External Device, use an integer from 0 to 255 to enter how many times the Display retransmits the command.
Wait To Send	Use an integer from 0 to 255 to enter standby time (ms) for the Display from receiving packets to transmitting next commands.

■ Device Setting

To display the setting screen, touch [Device/PLC Settings] from [Peripheral Equipment Settings]. Touch the External Device you want to set from the displayed list, and touch [Device Settings].

Comm.	Device	Option		
Temp. Controller CompoWay/F		[COM1]	Page 1/1	
Device/PLC Name		[PLC1] ▼		
Series		E5A/E/C/GN		
Unit No.		[1] ▲▼		
Exit		Back		2005/12/16 16:55:02

Setup Items	Setup Description
Device/PLC name	Select the External Device to set. Device name is a title of the External Device set with GP-Pro EX. (Default value [PLC1])
Series	Displays a model of the External Device.
Unit No.	Enter the unit No. for HOST link.

■ Option

To display the setting screen, touch [Device/PLC Settings] from [Peripheral Settings]. Touch the External Device you want to set from the displayed list, and touch [Option].

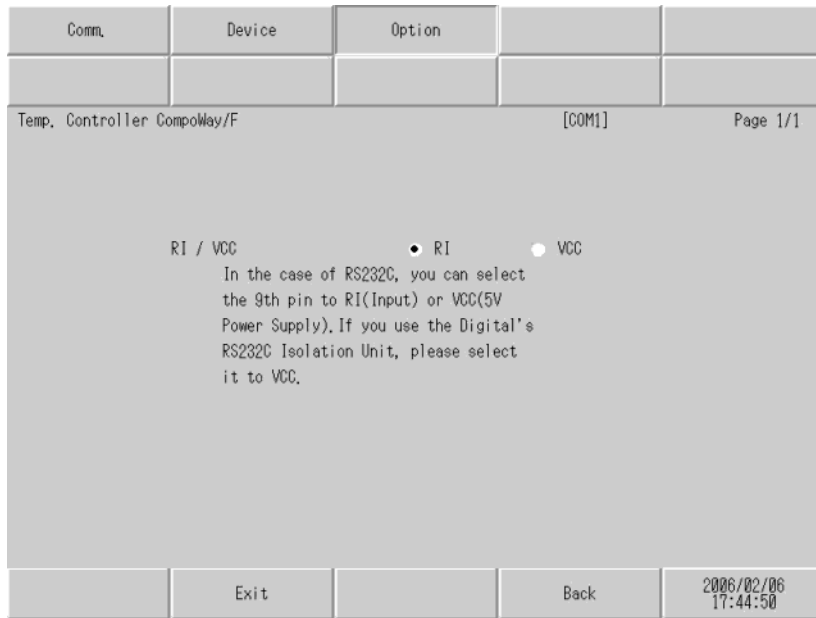

Setup Items	Setup Description
RI/VCC	Switches RI/VCC of the 9th pin. It is necessary to change RI/5V by changeover switch of IPC when connect with IPC. Please refer to the manual of the IPC for more detail.

5 Cable Diagram

The cable diagram shown below may be different from the cable diagram recommended by OMRON Corporation. Please be assured there is no operational problem in applying the cable diagram shown in this manual.

- The FG pin of the main body of the External Device must be D-class grounded. Please refer to the manual of the External Device for more details.
- SG and FG are connected inside the Display. When connecting SG to the External Device, design the system not to form short-circuit loop.
- Connect the isolation unit, when communication is not stabilized under the influence of a noise etc..

Recommended cable

- RS232C

Temperature Controller	Cable
E5EN-□□□□□-FLK E5AN-□□□□□-FLK	Twist pair shield cable AWG28 or higher

- RS485

Temperature Controller	Cable
E5EN-□□□□□-FLK E5AN-□□□□□-FLK E5CN-□□□□□-FLK E5AR-□□□□□□□□□-FLK E5ER-□□□□□□□□□-FLK	AWG28 or higher
E5GN-□□□□□-FLK E5ZN-□□□□□-FLK	AWG24 to 14

Cable Diagram 1

Display (Connection Port)	Cable	Remarks
GP (COM1) LT (COM1) IPC*1 PC/AT	Your own cable	Cable length: 15m or less

*1 Only the COM port which can communicate by RS-232C can be used.
 ■ COM Port of IPC (page 4)

When using your own cable

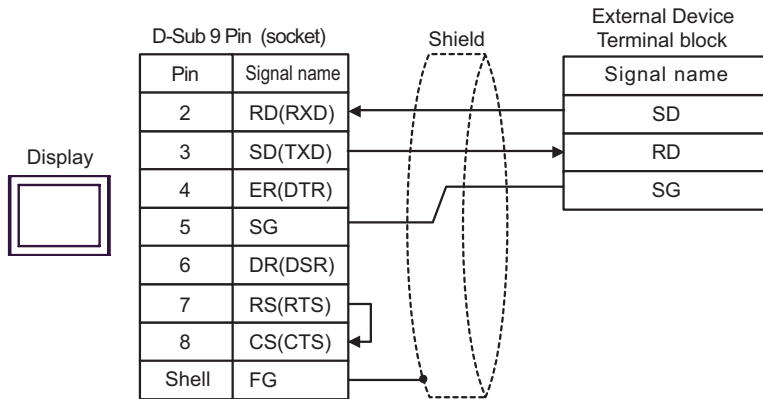

Cable Diagram 2

Display (Connection Port)	Cable		Remarks
GP*1 (COM1) AGP-3302B (COM2) LT (COM1)	A	COM port conversion adapter by Pro-face CA3-ADPCOM-01 + Terminal block conversion adapter by Pro-face CA3-ADPTRM-01 + Your own cable	Cable length: 500m or less
	B	Your own cable	
GP*2 (COM2)	C	Online adapter by Pro-face CA4-ADPONL-01 + Terminal block conversion adapter by Pro-face CA3-ADPTRM-01 + Your own cable	
	D	Online adapter by Pro-face CA4-ADPONL-01 + Your own cable	
IPC*3	E	COM port conversion adapter by Pro-face CA3-ADPCOM-01 + Terminal block conversion adapter by Pro-face CA3-ADPTRM-01 + Your own cable	
	F	Your own cable	

*1 All GP models except AGP-3302B

*2 All GP models except GP-3200 series and AGP-3302B

*3 Only the COM port which can communicate by RS-422/485 (2 wire) can be used.
 ■ COM Port of IPC (page 4)

A) When using the COM port conversion adapter (CA3-ADPCOM-01) and the terminal block conversion adapter (CA3-ADPTRM-01) by Pro-face

- 1:1 Connection

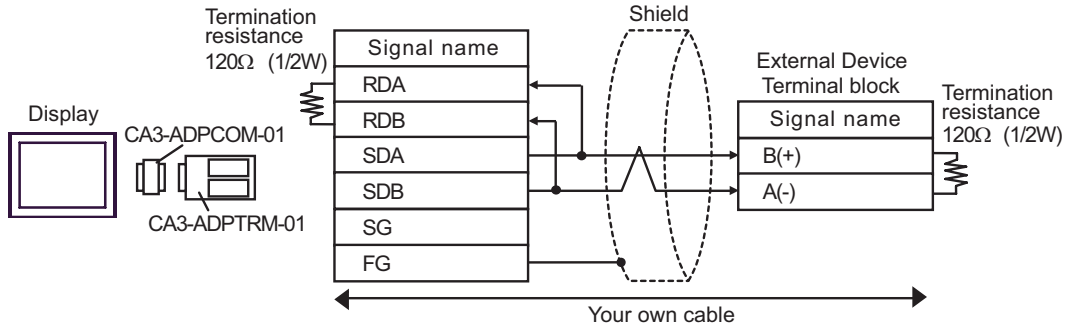

- 1: n connection

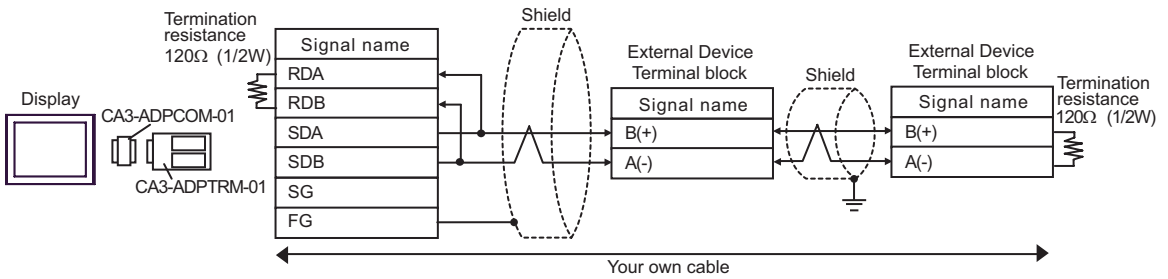

B) When using your own cable

- 1:1 Connection

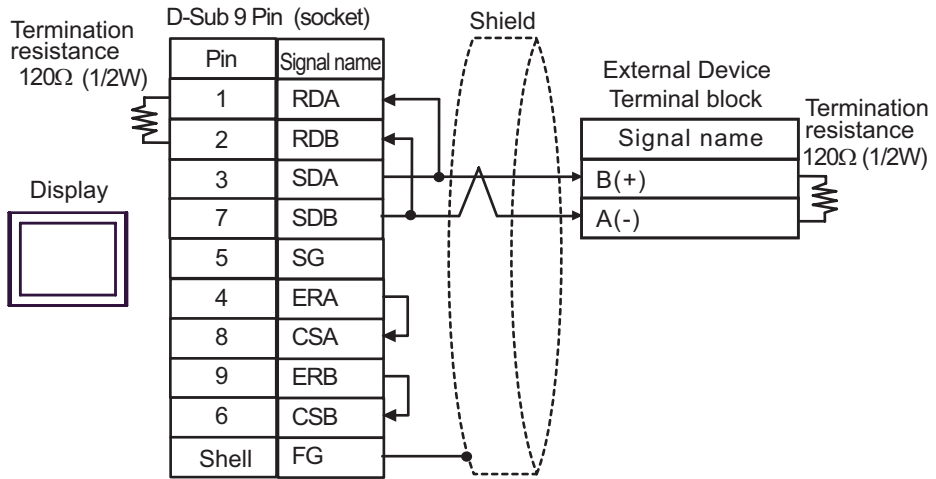

- 1:n Connection

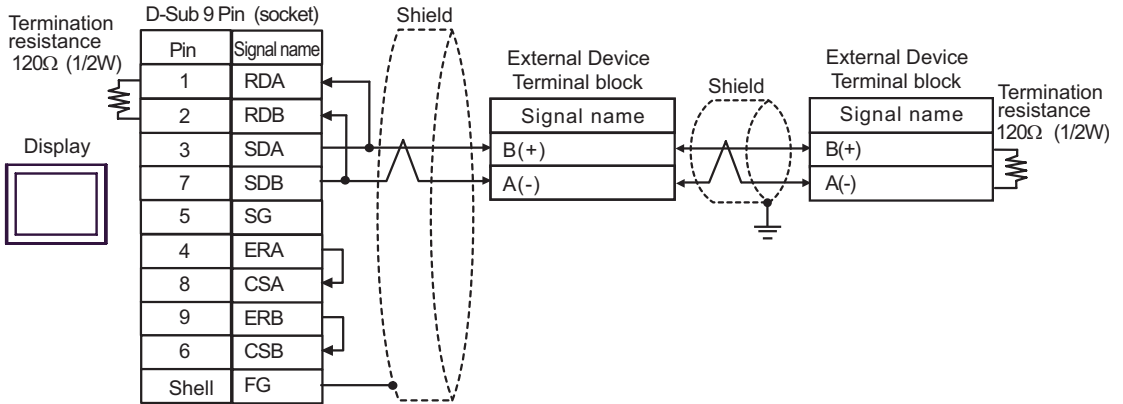

C) When using the online adapter (CA4-ADPONL-01), the terminal block conversion adapter (CA3-ADPTRM-01) by Pro-face

- 1:1 Connection

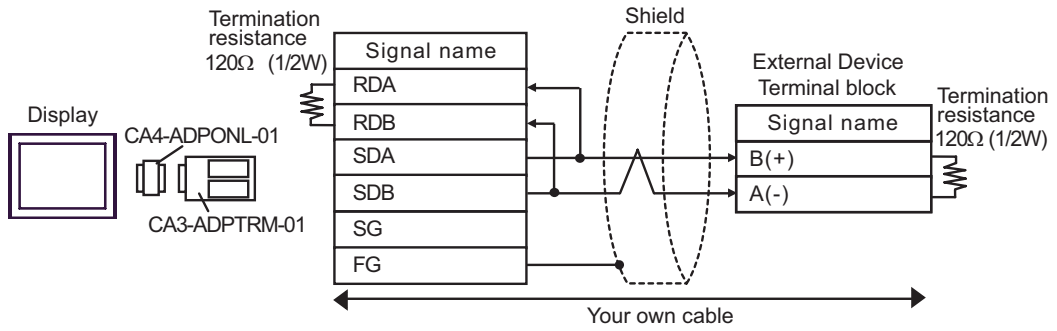

- 1:n Connection

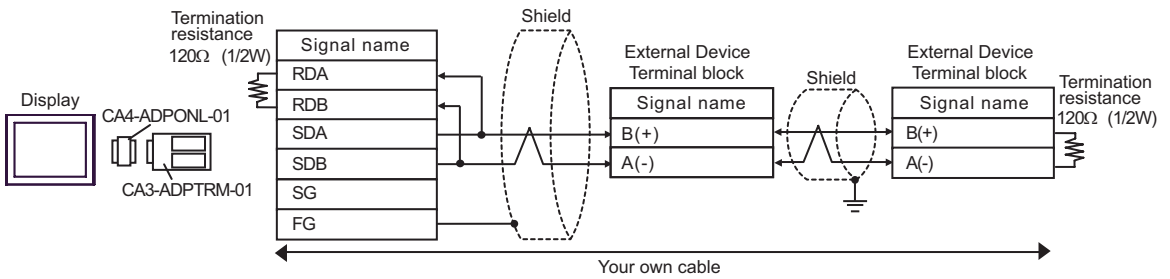

D) When using the online adapter (CA4-ADPONL-01) by Pro-face and your own cable

- 1:1 Connection

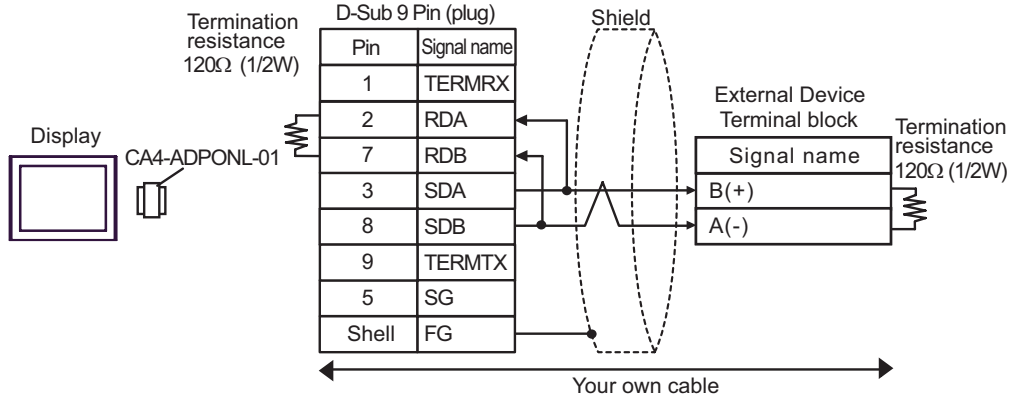

- 1:n Connection

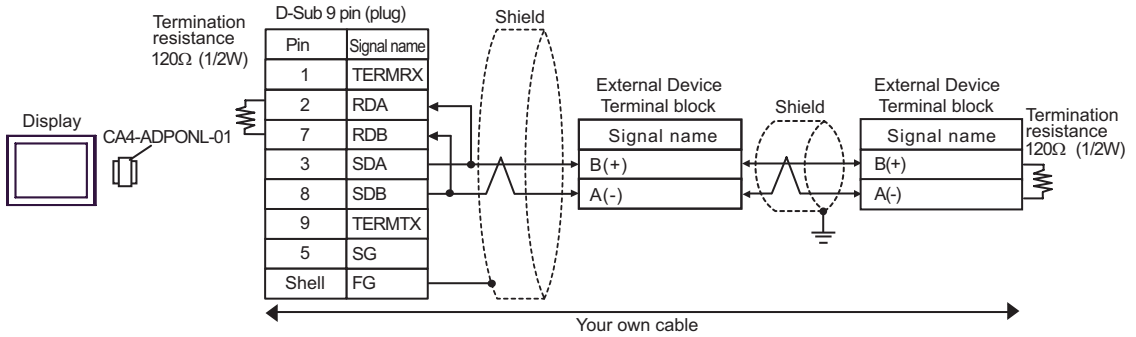

E) When using the COM port conversion adapter (CA3-ADPCOM-01) and the terminal block conversion adapter (CA3-ADPTRM-01) by Pro-face

- 1:1 Connection

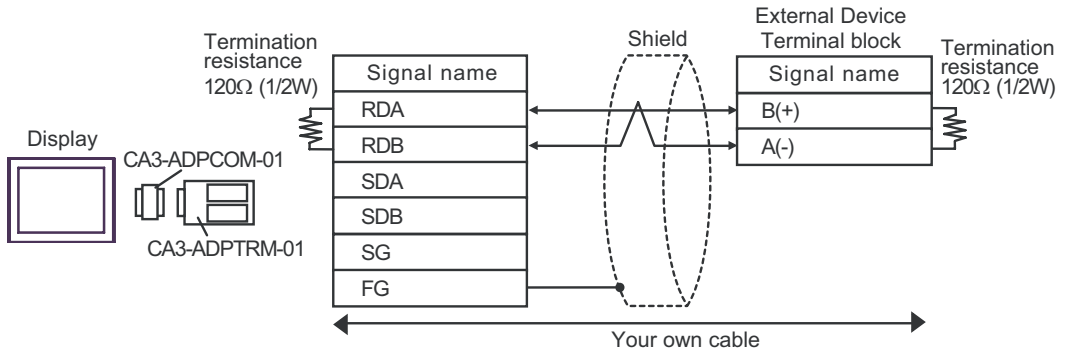

- 1: n connection

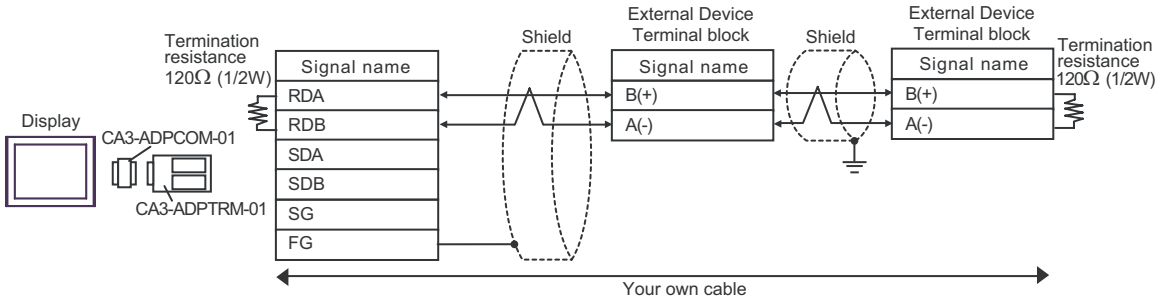

F) When using your own cable

- 1:1 Connection

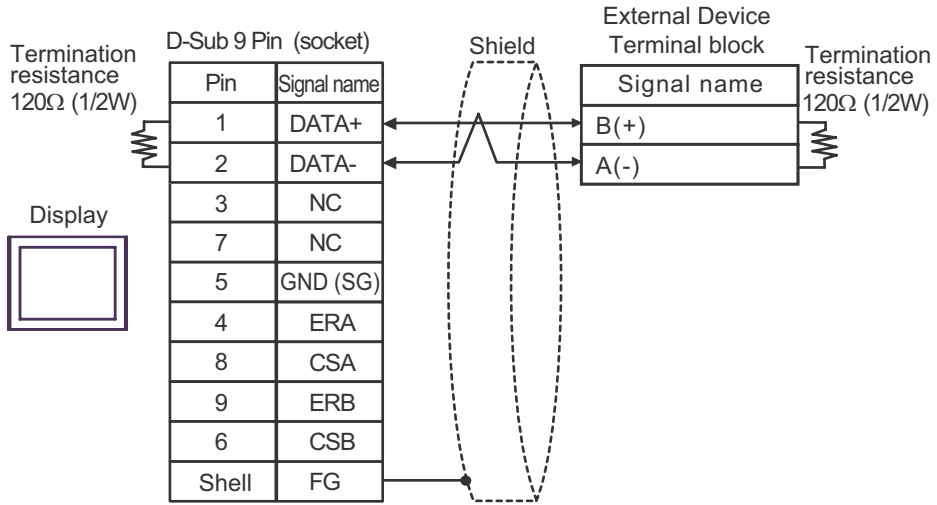

- 1:n Connection

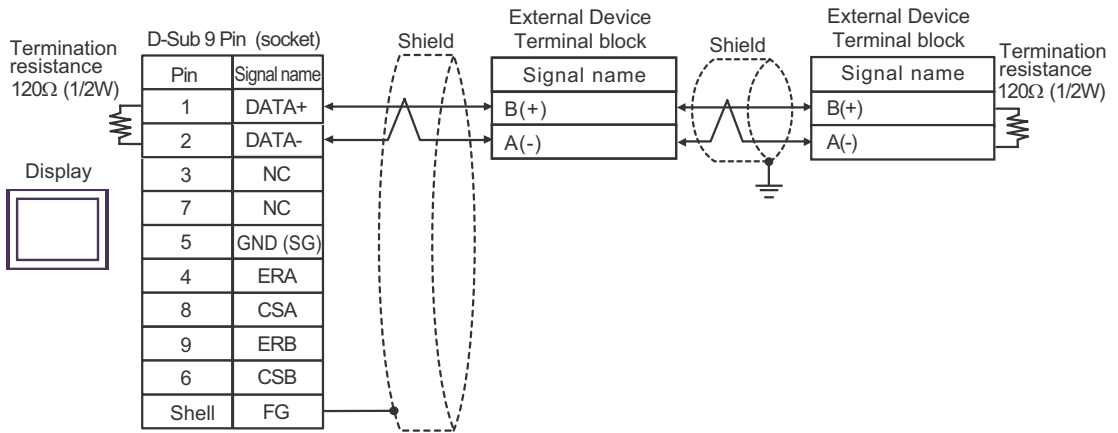



6 Supported device

Range of supported device address is shown in the table below. Please note that the actually supported range of the devices varies depending on the External Device to be used. Please check the actual range in the manual of your External Device.

6.1 THERMACNEO(E5AN/E5EN/E5CN/E5GN)

 This address can be specified as system data area.

Device	Bit Address		Word Address		32bit	Remarks
	11-segment display	7-segment display	11-segment display	7-segment display		
Variable Areas* ¹	C0000.00- C0009.31	C0000.00- C0005.31	C0000- C0009	C0000- C0005		Double Word Device* ^{2*3}
	C1000.00- C1002A.31	C1000.00- C1001C.31	C1000- C1002A	C1000- C1001C		Double Word Device* ²
	C3000.00- C30056.31	C3000.00- C30037.31	C3000- C30056	C3000- C30037		Double Word Device* ^{2*4}
Operation command* ⁶	-	-	A0000- A0011	A0000- A0008		Word Device* ⁵ 

- *1 Available variable area range varies depending on the using Temperature Controller. Refer to the manual of OMRON Temperature Controller for setting.
- *2 When you write the bit address, the Display reads the word address corresponding to that of the External Device first. Then, it changes the target bit address among the word data once read and returns the word data to the External Device. Note that the correct data may not be written if you change the word address value in the ladder program while the Display reads the data of the External Device and returns it to the External Device.
- *3 Write disable
- *4 When writing, switch the setting area of the Temperature Controller to setting area 1.
- *5 Read disable
- *6 When executing the operation command (write), specify the directive code for the device address. Set the related information for the writing value. Set the related information in hexadecimal number, such as 0x00, 0x01. Set the device code to be used in the painting software as A, and enter each command code instead of the device address.

■ Command code list

Command code	Related information	Command comment	Device address
00	00: OFF(Disabled) 01: ON (Enabled)	Communication writing	A0000
01	00: Run 01: Stop	Run/Stop	A0001
02	00: Target value 0 01: Target value 1 02: Target value 2 03: Target value 3	Multi-SP	A0002
03	00: Cancel 01: AT execute	ATexecute/cancel	A0003
04	00: Backup 01: RAM	Write mode	A0004

continued to next page

Command code	Related information	Command comment	Device address
05	00	Save RAM data	A0005
06	00	Soft reset ^{*1}	A0006
07	00	Setting area 1 transfer	A0007
08	00	Protect level transfer	A0008
09	00: Auto mode 01: Manual mode	Auto/Manual	A0009
0B	00: Default value 01: Value for default value setting service	Initialize settings	A000B
11	00: Reset 01: Start	Program start	A0011

*1 A soft reset will not respond.

IMPORTANT • To enable "Use System Area" in the system area setting of GP-Pro EX may cause a malfunction. Do not set "Use System Area".

NOTE • You can set only Read Area Size for the system area available to use in the Temperature Controller. Please refer to the GP-Pro EX Reference Manual for Read Area Size.
Cf. GP-Pro EX Reference Manual "Appendix 1.4 LS Area (only for direct access method)"

- Please refer to the precautions on manual notation for icons in the table.
☞ "Manual Symbols and Terminology"
- Even if you use the nonexistent address, read error may not be displayed. In this case, "0" is retained for the read data. Note that the writing error is displayed.

6.2 THERMACR(E5AR/E5ER)

H/L This address can be specified as system data area.

Device	Bit Address	Word Address	32bit	Remarks
Variable Areas ^{*1}	C00000.00-C00002.31 C00004.00-C00005.31 C00100.00-C00102.31 C00104.00-C00105.31 C00200.00-C00202.31 C00204.00-C00205.31 C00300.00-C00302.31 C00304.00-C00305.31	C00000-C00002 C00004-C00005 C00100-C00102 C00104-C00105 C00200-C00202 C00204-C00205 C00300-C00302 C00304-C00305	H/L	Double Word Device ^{*2*3}
	C10003.00-C10009.31 C10103.00-C10109.31 C10203.00-C10209.31 C10303.00-C10309.31	C10003-C10009 C10103-C10109 C10203-C10209 C10303-C10309		Double Word Device ^{*2*3}
	C40000.00-C4007F.31 C40100.00-C4017F.31 C40200.00-C4027F.31 C40300.00-C4037F.31	C40000-C4007F C40100-C4017F C40200-C4027F C40300-C4037F		Double Word Device ^{*2*3}
	C50000.00-C5007F.31 C50100.00-C5017F.31 C50200.00-C5027F.31 C50300.00-C5037F.31	C50000-C5007F C50100-C5017F C50200-C5027F C50300-C5037F		Double Word Device ^{*2}
	C60000.00-C6007F.31 C60100.00-C6017F.31 C60200.00-C6027F.31 C60300.00-C6037F.31	C60000-C6007F C60100-C6017F C60200-C6027F C60300-C6037F		Double Word Device ^{*2}
	C70000.00-C7007F.31 C70100.00-C7017F.31 C70200.00-C7027F.31 C70300.00-C7037F.31	C70000-C7007F C70100-C7017F C70200-C7027F C70300-C7037F		Double Word Device ^{*2}
	C80000.00-C8007F.31 C80100.00-C8017F.31 C80200.00-C8027F.31 C80300.00-C8037F.31	C80000-C8007F C80100-C8017F C80200-C8027F C80300-C8037F		Double Word Device ^{*2}
	C90000.00-C9007F.31 C90100.00-C9017F.31 C90200.00-C9027F.31 C90300.00-C9037F.31	C90000-C9007F C90100-C9017F C90200-C9027F C90300-C9037F		Double Word Device ^{*2}
	CA0000.00-CA007F.31 CA0100.00-CA017F.31 CA0200.00-CA027F.31 CA0300.00-CA037F.31	CA0000-CA007F CA0100-CA017F CA0200-CA027F CA0300-CA037F		Double Word Device ^{*2}
	CB0000.00-CB007F.31 CB0100.00-CB017F.31 CB0200.00-CB027F.31 CB0300.00-CB037F.31	CB0000-CB007F CB0100-CB017F CB0200-CB027F CB0300-CB037F		Double Word Device ^{*2}
	CC0000.00-CC0039.31 CC0100.00-CC0139.31 CC0200.00-CC0239.31 CC0300.00-CC0339.31	CC0000-CC0039 CC0100-CC0139 CC0200-CC0239 CC0300-CC0339		Double Word Device ^{*2*4}

continued to next page

Device	Bit Address	Word Address	32bit	Remarks
Variable Areas	CD0000.00-CD0039.31 CD0100.00-CD0139.31 CD0200.00-CD0239.31 CD0300.00-CD0339.31	CD0000-CD0039 CD0100-CD0139 CD0200-CD0239 CD0300-CD0339	H/L	Double Word Device *2 *4
	CE0000.00-CE0039.31 CE0100.00-CE0139.31 CE0200.00-CE0239.31 CE0300.00-CE0339.31	CE0000-CE0039 CE0100-CE0139 CE0200-CE0239 CE0300-CE0339		Double Word Device *2 *4
	CF0000.00-CF0039.31 CF0100.00-CF0139.31 CF0200.00-CF0239.31 CF0300.00-CF0339.31	CF0000-CF0039 CF0100-CF0139 CF0200-CF0239 CF0300-CF0339		Double Word Device *2 *4
	D00000.00-D00039.31 D00100.00-D00139.31 D00200.00-D00239.31 D00300.00-D00339.31	D00000-D00039 D00100-D00139 D00200-D00239 D00300-D00339		Double Word Device *2 *4
	D10000.00-D10039.31 D10100.00-D10139.31 D10200.00-D10239.31 D10300.00-D10339.31	D10000-D10039 D10100-D10139 D10200-D10239 D10300-D10339		Double Word Device *2 *4
	D20000.00-D20039.31 D20100.00-D20139.31 D20200.00-D20239.31 D20300.00-D20339.31	D20000-D20039 D20100-D20139 D20200-D20239 D20300-D20339		Double Word Device *2 *4
	D30000.00-D30039.31 D30100.00-D30139.31 D30200.00-D30239.31 D30300.00-D30339.31	D30000-D30039 D30100-D30139 D30200-D30239 D30300-D30339		Double Word Device *5
Operation command *6	-	A0000-A000D	H/L	Word Device *5 Bi 15

*1 Available variable area range varies depending on the using Temperature Controller. Refer to the manual of OMRON Temperature Controller for setting.

*2 When you write the bit address, the Display reads the word address corresponding to that of the External Device first. Then, it changes the target bit address among the word data once read and returns the word data to the External Device. Note that the correct data may not be written if you change the word address value in the ladder program while the Display reads the data of the External Device and returns it to the External Device.

*3 Write disable

*4 When writing, switch the setting area of the Temperature Controller to setting area 1.

*5 Read disable

*6 When executing the operation command (write), specify the directive code for the device address. Set the related information for the writing value. Set the related information in hexadecimal number, such as 0x00, 0x01. Set the device code to be used in the painting software as A, and enter each command code instead of the device address.

■ Command code list

Command code	Related information		Command comment	Device address
	Higher byte	Lower byte		
00	0*1	0: OFF (Disabled) 1: ON (Enabled)	Communication writing	A0000

continued to next page

Command code	Related information		Command comment	Device address
	Higher byte	Lower byte		
01	0 to 3, F *2	0: Run 1: Stop	Run/Stop	A0001
02	0 to 3, F *2	0 to 7: Bank 0 to 7	Bank switch	A0002
03	0 to 3, F *2	0: Currently selected PIDset No. 1 to 8: PIDset No.	AT execute	A0003
04	0*1	0: Backup mode 1: RAM write mode	Write mode	A0004
05	0*1	0	Save RAM data	A0005
06	0*1	0	Soft reset	A0006
07	0*1	0	Setting area 1 transfer	A0007
08	0*1	0	Protect level transfer	A0008
09	0 to 3, F *2	0: Auto mode 1: Manual mode	Auto/Manual	A0009
0A	0 to 3, F *2	0: Cancel	AT cancel	A000A
0B	0*1	0	Initialize settings	A000B
0C	0 to 3, F *2	0	Cancel latch	A000C
0D	0 to 3, F *2	0: LSP 1: RSP	SP mode	A000D

*1 Operates for all channels.

*2 Specify for every channel. (0: CH1, 1:CH2, 2:CH3, 3:CH4, F:All channels)

A soft reset will not respond. (No service PDU response)

When all channels are specified, only enabled channels will respond and processing will begin from Channel 1.

If an error is detected on any channel, "Operation error" will be defined. When all channels end normally, normal end will be defined.



IMPORTANT • To enable "Use System Area" in the system area setting of GP-Pro EX may cause a malfunction. Do not set "Use System Area".

NOTE • You can set only Read Area Size for the system area available to use in the Temperature Controller. Please refer to the GP-Pro EX Reference Manual for Read Area Size.
Cf. GP-Pro EX Reference Manual "Appendix 1.4 LS Area (only for direct access method)"

- Please refer to the precautions on manual notation for icons in the table.
☞ "Manual Symbols and Terminology"
- Even if you use the nonexistent address, read error may not be displayed. In this case, "0" is retained for the read data. Note that the writing error is displayed.

6.3 In-Panel NEO

 This address can be specified as system data area.

Device	Bit Address	Word Address	32bit	Remarks
Variable Areas ^{*1}	C00000.00-C00006.31 C00100.00-C00106.31	C00000-C00006 C00100-C00106		Double Word Device ^{*2*3}
	C10000.00-C10019.31 C10100.00-C10119.31	C10000-C10019 C10100-C10119		Double Word Device ^{*2}
	C30000.00-C3003E.31 C30100.00-C3013E.31	C30000-C3003E C30100-C3013E		Double Word Device ^{*2 *4}
	C50000.00-C50000.31 C50100.00-C50100.31	C50000 C50100		Double Word Device ^{*2}
	C70000.00-C70001.31 C70100.00-C70101.31	C70000-C70001 C70100-C70101		Double Word Device ^{*2*4}
Operation command ^{*6}	-	A0000-A000C		Word Device ^{*5}

*1 Available variable area range varies depending on the using Temperature Controller. Refer to the manual of OMRON Temperature Controller for setting.

*2 When you write the bit address, the Display reads the word address corresponding to that of the External Device first. Then, it changes the target bit address among the word data once read and returns the word data to the External Device. Note that the correct data may not be written if you change the word address value in the ladder program while the Display reads the data of the External Device and returns it to the External Device.

*3 Write disable

*4 When writing, switch the setting area of the Temperature Controller to setting area 1.

*5 Read disable

*6 When executing the operation command (write), specify the directive code for the device address. Set the related information for the writing value. Set the related information in hexadecimal number, such as 0x00, 0x01. Set the device code to be used in the painting software as A, and enter each command code instead of the device address.

■ Command code list

Command code	Related information ^{*2}	Command comment	Device address
00	“00” or “10”:OFF(disabled) “01” or “11”:ON(enabled)	Communication writing	A0000
01	“00”: Run CH1 “01”: Stop CH1 “10”: Run CH2 “11”: Stop CH2 “F0”: Run CH1, CH2 ^{*1} “F1”: Stop CH1, CH2 ^{*1}	Run/Stop	A0001
02	“00”: Select target value 0 for CH1 “01”: Select target value 1 for CH1 “10”: Select target value 0 for CH2 “11”: Select target value 1 for CH2 “F0”: Select target value 0 for CH1, CH2 ^{*1} “F1”: Select target value 1 for CH1, CH2 ^{*1}	Multi-SP	A0002

continued to next page

Command code	Related information * 2	Command comment	Device address
03	"00": Cancel CH1 AT "01": Execute CH1 AT "10": Cancel CH2 AT "11": Execute CH2 AT "F0": Cancel CH1, CH2 AT* ¹ "F1": Execute CH1, CH2 AT* ¹	ATexecute/cancel	A0003
04	"00" or "10": Backup "01" or "11": RAM	Write mode	A0004
05	"00" or "10"	Save RAM data	A0005
06	"00" or "10"	Soft reset	A0006
07	"00" or "10"	Setting area 1 transfer	A0007
08	"00" or "10"	Protect level transfer	A0008
09	"00": Auto for CH1 "01": Manual for CH1 "10": Auto for CH2 "11": Manual for CH2 "F0": Auto for CH1, CH2* ¹ "F1": Manual for CH1, CH2* ¹	Auto/Manual	A0009
0A	"00" or "10"	PV hold	A000A
0B	"00" or "10"	Initialize settings	A000B
0C	"00": Cancel alarm latch for CH1* ¹ "01": Cancel alarm latch 2 for CH1* ¹ "02": Cancel alarm latch 3 for CH1* ¹ "0F": Cancel all alarm latches for CH1* ¹ "10": Cancel alarm latch for CH2* ¹ "11": Cancel alarm latch 2 for CH2* ¹ "12": Cancel alarm latch 3 for CH2* ¹ "1F": Cancel all alarm latches for CH2* ¹ "F0": Cancel alarm latch for CH1, CH2* ¹ "F1": Cancel alarm latch 2 for CH1, CH2* ¹ "F2": Cancel alarm latch 3 for CH1, CH2* ¹ "FF": Cancel all alarm latches for CH2* ¹	Cancel alarm latch	A000C

*1 Upgraded pulse output models and analog output models can support these commands.

*2 Command codes for which the related information is indicated as "00" or "10" or "01" or "11" use the same command for both CH1 and CH2. You can use either value in the related information. (The result will be the same.)

IMPORTANT • To enable "Use System Area" in the system area setting of GP-Pro EX may cause a malfunction. Do not set "Use System Area".

NOTE • You can set only Read Area Size for the system area available to use in the Temperature Controller. Please refer to the GP-Pro EX Reference Manual for Read Area Size.
Cf. GP-Pro EX Reference Manual "Appendix 1.4 LS Area (only for direct access method)"

- Please refer to the precautions on manual notation for icons in the table.

 "Manual Symbols and Terminology"

- Even if you use the nonexistent address, read error may not be displayed. In this case, "0" is retained for the read data. Note that the writing error is displayed.

7 Device Code and Address Code

Use device code and address code when you select "Device & Address" for the address type in data displays.

7.1 THERMACNEO(E5AN/E5EN/E5CN/E5GN)

Device	Device Name	Device Code (HEX)	Address Code
Variable Areas	C0	0080	Word Address
	C1	0081	Word Address
	C3	0082	Word Address
Operation command	A	0000	Word Address

7.2 THERMACR(E5AR/E5ER)

Device	Device Name	Device Code (HEX)	Address Code
Variable Areas	C0	0080	Word Address
	C1	0081	Word Address
	C4	0083	Word Address
	C5	0084	Word Address
	C6	0085	Word Address
	C7	0086	Word Address
	C8	0087	Word Address
	C9	0088	Word Address
	CA	0089	Word Address
	CB	008A	Word Address
	CC	008B	Word Address
	CD	008C	Word Address
	CE	008D	Word Address
	CF	008E	Word Address
	D0	008F	Word Address
	D1	0090	Word Address
D2	0091	Word Address	
D3	0092	Word Address	
Operation command	A	0000	Word Address

7.3 In-Panel NEO

Device	Device Name	Device Code (HEX)	Address Code
Variable Areas	C0	0080	Word Address
	C1	0081	Word Address
	C3	0082	Word Address
	C5	0084	Word Address
	C7	0086	Word Address
Operation command	A	0000	Word Address

8 Error Messages

Error messages are displayed on the screen of Display as follows: "No. : Device Name: Error Message(Error Occurrence Area)". Each description is shown below.

Item	Description
No.	Error No.
Device Name	Name of External Device where error occurs. Name of External Device is a title of External Device set with GP-Pro EX.((Initial value[PLC1])
Error Message	Displays messages related to the error which occurs.
Error Occurrence Area	Displays IP address or device address of External Device where error occurs, or error codes received from External Device. <div style="border: 1px solid black; padding: 2px; display: inline-block;">NOTE</div> <ul style="list-style-type: none"> • IP address is displayed such as "IP address(Decimal): MAC address (Hex)". • Device address is displayed such as "Address: Device address". • Received error codes are displayed such as "Decimal[Hex]".

Display Examples of Error Messages

"RHAA035: PLC1: Error has been responded for device write command (Error Code: 2[02H])"

NOTE

- Please refer to the manual of External Device for more detail of received error codes.
- Please refer to "When an error message is displayed (Error code list)" of "Maintenance/Troubleshooting" for a common error message to the driver.