

Digital Controller SIO Driver

1	System Configuration.....	3
2	Selection of External Device	8
3	Example of Communication Setting.....	9
4	Setup Items.....	65
5	Cable Diagram	70
6	Supported Device.....	103
7	Device Code and Address Code.....	114
8	Error Messages.....	116

PREFACE

This manual describes how to connect the Display and the External Device (target Controller).

In this manual, the connection procedure will be described by following the below sections:

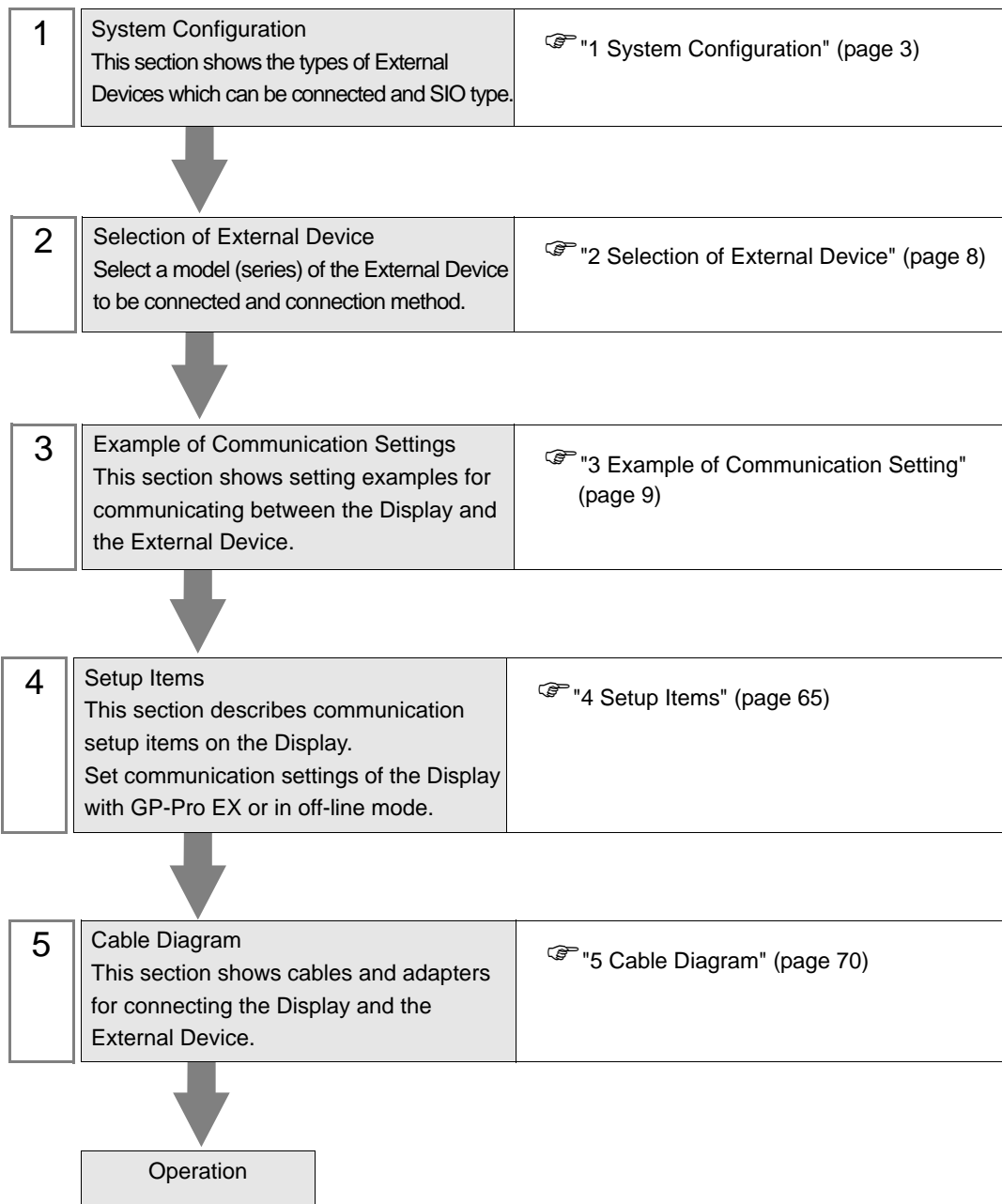

1 System Configuration

The system configuration in the case when the External Device of Yamatake Corporation and the Display are connected is shown.

Series	CPU	Link I/F	SIO Type	Setting Example	Cable Diagram
SDC10	C10□□□□□05□□	Terminal block on the controller	RS422/485(2 wire)	Setting Example 1 (page 9)	Cable Diagram 5 (page 89)
SDC15	C15□□□□□03□□ C15□□□□□06□□	Terminal block on the controller	RS422/485(2 wire)	Setting Example 2 (page 11)	Cable Diagram 6 (page 96)
SDC20/21	C20□□□□□03□□ C20□□□□□05□□ C20□□□□□10□□ C21□□□□□04□□ C21□□□□□07□□ C21□□□□□09□□	Terminal block on the controller	RS232C	Setting Example 3 (page 13)	Cable Diagram 1 (page 70)
	C20□□□□□02□□ C20□□□□□04□□ C20□□□□□09□□ C21□□□□□03□□ C21□□□□□06□□ C21□□□□□08□□	Terminal block on the controller	RS422/485(4 wire) RS422/485(2 wire)	Setting Example 4 (page 15) Setting Example 5 (page 17)	Cable Diagram 2 (page 71) Cable Diagram 3 (page 75)
SDC25/26	C25□□□□□□2□□ C26□□□□□□2□□	Terminal block on the controller	RS422/485(2 wire)	Setting Example 6 (page 19)	Cable Diagram 6 (page 96)
SDC30/31	C30□□□□□040□□ C30□□□□□041□□ C31□□□□□045□□ C31□□□□□446□□ C31□□□□□546□□	Terminal block on the controller	RS422/485(4 wire)	Setting Example 7 (page 21)	Cable Diagram 2 (page 71)
			RS422/485(2 wire)	Setting Example 8 (page 23)	Cable Diagram 3 (page 75)
SDC35/36	C35□□□□□□2□□ C35□□□□□□4□□ C36□□□□□□2□□ C36□□□□□□4□□	Terminal block on the controller	RS422/485(2 wire)	Setting Example 9 (page 25)	Cable Diagram 6 (page 96)
SDC40A	C40A□□□□□□□3□□	Terminal block on the controller	RS232C	Setting Example 10 (page 27)	Cable Diagram 1 (page 70)
	C40A□□□□□□□2□□	Terminal block on the controller	RS422/485(4 wire)	Setting Example 11 (page 29)	Cable Diagram 2 (page 71)
			RS422/485(2 wire)	Setting Example 12 (page 31)	Cable Diagram 3 (page 75)

Series	CPU	Link I/F	SIO Type	Setting Example	Cable Diagram
SDC40B	C40B□□□□□□□□3□□	Terminal block on the controller	RS232C	Setting Example 13 (page 33)	Cable Diagram 1 (page 70)
	C40B□□□□□□□□2□□	Terminal block on the controller	RS422/485(4 wire)	Setting Example 14 (page 35)	Cable Diagram 2 (page 71)
			RS422/485(2 wire)	Setting Example 15 (page 37)	Cable Diagram 3 (page 75)
SDC40G	C40G□□□□□□□□095□□	Terminal block on the controller	RS422/485(4 wire)	Setting Example 16 (page 39)	Cable Diagram 2 (page 71)
			RS422/485(2 wire)	Setting Example 17 (page 41)	Cable Diagram 3 (page 75)
DMC10	DMC10□□□□□□□□□	Terminal block on the controller	RS422/485(2 wire)	Setting Example 18 (page 43)	Cable Diagram 4 (page 82)
DCP31	P31A□□□□□□□□2□□	Terminal block on the controller	RS422/485(4 wire)	Setting Example 19 (page 45)	Cable Diagram 2 (page 71)
			RS422/485(2 wire)	Setting Example 20 (page 47)	Cable Diagram 3 (page 75)
DCP32	P32A□□□□□□□□2□□	Terminal block on the controller	RS422/485(4wire)	Setting Example 21 (page 49)	Cable Diagram 2 (page 71)
			RS422/485(2 wire)	Setting Example 22 (page 51)	Cable Diagram 3 (page 75)
DCP551	DCP551□□□□2□□	Terminal block on the controller	RS232C	Setting Example 23 (page 53)	Cable Diagram 1 (page 70)
			RS422/485(4 wire)	Setting Example 24 (page 55)	Cable Diagram 2 (page 71)
			RS422/485(2 wire)	Setting Example 25 (page 57)	Cable Diagram 3 (page 75)
DCP552	DCP552□□□□2□□	Terminal block on the controller	RS232C	Setting Example 26 (page 59)	Cable Diagram 1 (page 70)
			RS422/485(4wire)	Setting Example 27 (page 61)	Cable Diagram 2 (page 71)
			RS422/485(2 wire)	Setting Example 28 (page 63)	Cable Diagram 3 (page 75)

◆ Connection Configuration

[Connection example 1:n]

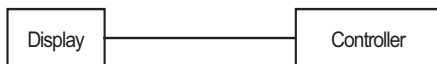

[Connection example 1:n When using COM1 or COM2]

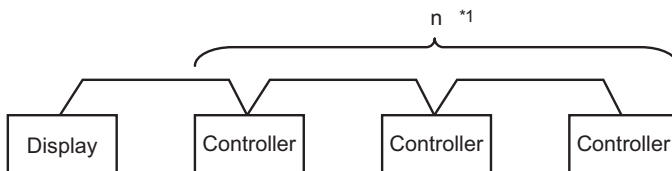

[Connection example 1:n When using COM1 and COM2]

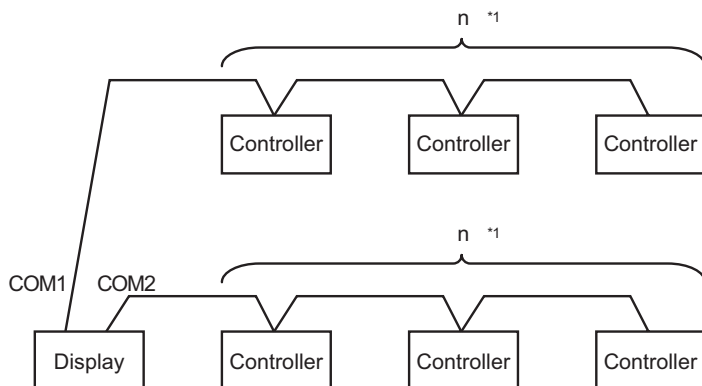

*1 You can connect maximum 16 units of External Device. Note that maximum 15 units can be connected if DMC10 is included.

NOTE

- Do not add the termination resistance when the Controller to be connected using 1:n connection includes the following series.

- SDC15
- SDC25/26
- SDC35/36
- DMC10

■ COM Port of IPC

When connecting IPC with External Device, the COM port which can be used changes with series and SIO type. Please refer to the manual of IPC for details.

Usable port

Series	Usable port		
	RS-232C	RS-422/485(4 wire)	RS-422/485(2 wire)
PS-2000B	COM1 ^{*1} , COM2, COM3 ^{*1} , COM4	-	-
PS-3450A, PS-3451A	COM1, COM2 ^{*1*2}	COM2 ^{*1*2}	COM2 ^{*1*2}
PS-3650A, PS-3651A	COM1 ^{*1}	-	-
PS-3700A (Pentium®4-M) PS-3710A	COM1 ^{*1} , COM2 ^{*1} , COM3 ^{*2} , COM4	COM3 ^{*2}	COM3 ^{*2}
PS-3711A	COM1 ^{*1} , COM2 ^{*2}	COM2 ^{*2}	COM2 ^{*2}
PL-3000B	COM1 ^{*1*2} , COM2 ^{*1} , COM3, COM4	COM1 ^{*1*2}	COM1 ^{*1*2}

*1 The RI/5V can be switched. Please switch with the change switch of IPC.

*2 It is necessary to set up the SIO type with the Dip switch. Please set up as follows according to SIO type to be used.

Dip switch setting: RS-232C

Dip switch	Setting	Description
1	OFF ^{*1}	Reserve (always OFF)
2	OFF	SIO type: RS-232C
3	OFF	
4	OFF	Output mode of SD (TXD) data: Always output
5	OFF	Terminal resistance (220Ω) insertion to SD (TXD): None
6	OFF	Terminal resistance (220Ω) insertion to RD (RXD): None
7	OFF	Short-circuit of SDA (TXA) and RDA (RXA): Does not Exist
8	OFF	Short-circuit of SDB (TXB) and RDB (RXB): Does not Exist
9	OFF	RS (RTS) Auto control mode: Disable
10	OFF	

*1 It is necessary to turn ON the set value, only when using PS-3450A and PS-3451A.

Dip switch setting: RS-422/485 (4 wire)

Dip switch	Setting	Description
1	OFF	Reserve (always OFF)
2	ON	SIO type: RS-422/485
3	ON	
4	OFF	Output mode of SD (TXD) data: Always output
5	OFF	Terminal resistance (220Ω) insertion to SD (TXD): None
6	OFF	Terminal resistance (220Ω) insertion to RD (RXD): None
7	OFF	Short-circuit of SDA (TXA) and RDA (RXA): Does not Exist
8	OFF	Short-circuit of SDB (TXB) and RDB (RXB): Does not Exist
9	OFF	RS (RTS) Auto control mode: Disable
10	OFF	

Dip switch setting: RS-422/485 (2 wire)

Dip switch	Setting	Description
1	OFF	Reserve (always OFF)
2	ON	SIO type: RS-422/485
3	ON	
4	OFF	Output mode of SD (TXD) data: Always output
5	OFF	Terminal resistance (220Ω) insertion to SD (TXD): None
6	OFF	Terminal resistance (220Ω) insertion to RD (RXD): None
7	ON	Short-circuit of SDA (TXA) and RDA (RXA): Exist
8	ON	Short-circuit of SDB (TXB) and RDB (RXB): Exist
9	ON	RS (RTS) Auto control mode: Enable
10	ON	

2 Selection of External Device

Select the External Device to be connected to the Display.

Setup Items	Setup Description
Maker	Select the maker of the External Device to be connected. Select "Yamatake Corporation".
Driver	Select a model (series) of the External Device to be connected and connection method. Select "Digital Controller SIO". Check the External Device which can be connected in "Digital Controller SIO" in system configuration. ☞ "1 System Configuration" (page 3)
Use System Area	Cannot use in this driver.
Port	Select the Display port to be connected to the External Device.

3 Example of Communication Setting

Examples of communication settings of the Display and the External Device, recommended by Digital Electronics Corp., are shown.

3.1 Setting Example 1

■ Setting of GP-Pro EX

◆ Communication Settings

To display the setting screen, select [Device/PLC Settings] from [System setting window] in workspace.

Device/PLC 1

Summary [Change Device/PLC](#)

Maker Yamatake Corporation Driver Digital Controller SIO Port COM1

Text Data Mode 1 [Change](#)

Communication Settings

SIO Type RS232C RS422/485(2wire) RS422/485(4wire)

Speed 9600

Data Length 7 8

Parity NONE EVEN ODD

Stop Bit 1 2

Flow Control NONE ER(DTR/CTS) XON/XOFF

Timeout 4 (sec)

Retry 2

Wait To Send 70 (ms)

RI / VCC RI VCC

In the case of RS232C, you can select the 9th pin to RI (Input) or VCC (5V Power Supply). If you use the Digital's RS232C Isolation Unit, please select it to VCC.

Default

Device-Specific Settings

Allowable No. of Device/PLCs 16 Unit(s)

No.	Device Name	Settings
1	PLC1	Series=SDC10, Device Address=1

IMPORT • When using SDC10, you need to set Wait To Send to 70ms or more.

◆ Device Setting

To display the setting screen, click  ([Setting]) of the External Device you want to set from [Device-Specific Settings] of [Device/PLC Settings].



■ Settings of External Device

Use the PARA key, ENT key, down key and up key in front of the Controller for communication settings of the External Device. Please refer to the manual of the Controller for more details.

◆ Procedure

1. Press and hold the PARA key in operation mode (3 seconds) to move to the parameter mode.
2. Press and hold the PARA key in parameter mode (3 seconds) to move to the setup mode.
3. Press the PARA key several times to display the setup items.
4. Use the down/up keys to select the setting contents. (Setting value will blink.)
5. When you stop operating for 2 seconds, blinking of the setting value ends to confirm the change.
6. Press and hold the PARA key (3 seconds) to move to the standard display.

◆ Setting Value

Setup Items	Setting Value
C22	1
C23	0

NOTE • Parameters to be set vary depending on the Controller. Please refer to the manual of the Controller for more details.

3.2 Setting Example 2

■ Setting of GP-Pro EX

◆ Communication Settings

To display the setting screen, select [Device/PLC Settings] from [System setting window] in workspace.

Device/PLC 1

Summary [Change Device/PLC](#)

Maker Yamatake Corporation Driver Digital Controller SIO Port COM1

Text Data Mode 1 [Change](#)

Communication Settings

SIO Type RS232C RS422/485(2wire) RS422/485(4wire)

Speed 9600

Data Length 7 8

Parity NONE EVEN ODD

Stop Bit 1 2

Flow Control NONE ER(DTR/CTS) XON/XOFF

Timeout 3 (sec)

Retry 2

Wait To Send 10 (ms)

RI / VCC RI VCC

In the case of RS232C, you can select the 9th pin to RI (Input) or VCC (5V Power Supply). If you use the Digital's RS232C Isolation Unit, please select it to VCC.

[Default](#)

Device-Specific Settings

Allowable No. of Device/PLCs 16 Unit(s)

No.	Device Name	Settings
1	PLC1	Series=SDC15,Device Address=1

◆ Device Setting

To display the setting screen, click  ([Setting]) of the External Device you want to set from [Device-Specific Settings] of [Device/PLC Settings].



■ Settings of External Device

Use the PARA key, mode key, down key and up key in front of the Controller for communication settings of the External Device. Please refer to the manual of the Controller for more details.

◆ Procedure

1. Press and hold the PARA key in operation display (2 seconds) to move to the parameter setting display.
2. Press and hold the PARA key in the parameter setting display (2 seconds) to move to the setup display.
3. Press the PARA key several times to display the setup items.
4. Use the down/up keys to select the setting contents. (Setting value will blink.)
5. When you stop key operation for 2 seconds, blinking of the setting value ends to confirm the change.
6. Press the mode key to move to the standard display.

◆ Setting Value

Setup Items	Setting Value
C64	0
C65	1
C66	1
C67	1
C68	0
C69	0

NOTE

- Parameters to be set vary depending on the Controller. Please refer to the manual of the Controller for more details.

3.3 Setting Example 3

■ Setting of GP-Pro EX

◆ Communication Settings

To display the setting screen, select [Device/PLC Settings] from [System setting window] in workspace.

Device/PLC 1 [Change Device/PLC](#)

Summary

Maker Driver Port

Text Data Mode [Change](#)

Communication Settings

SIO Type RS232C RS422/485(2wire) RS422/485(4wire)

Speed

Data Length 7 8

Parity NONE EVEN ODD

Stop Bit 1 2

Flow Control NONE ER(DTR/CTS) XON/XOFF

Timeout (sec)

Retry

Wait To Send (ms)

RI / VCC RI VCC

In the case of RS232C, you can select the 9th pin to RI (Input) or VCC (5V Power Supply). If you use the Digital's RS232C Isolation Unit, please select it to VCC.

Device-Specific Settings

Allowable No. of Device/PLCs: 16 Unit(s)

No.	Device Name	Settings
1	PLC1	Series=SDC20/21,Device Address=1

◆ Device Setting

To display the setting screen, click  ([Setting]) of the External Device you want to set from [Device-Specific Settings] of [Device/PLC Settings].



■ Settings of External Device

Use the ENT key, DISP key, down key and up key in front of the Controller for communication settings of the External Device. Please refer to the manual of the Controller for more details.

◆ Procedure

1. Press and hold the ENT key and the down key together (3 seconds or more) to display the setup items.
2. Press the down/up keys to select the setup items and press the ENT key.
3. Use the down/up keys to select the setup contents and press the ENT key.
4. Press the DISP key to move to the standard display.

◆ Setting Value

Setup Items	Setting Value
C31	1
C32	0
C33	0

NOTE • Parameters to be set vary depending on the Controller. Please refer to the manual of the Controller for more details.

3.4 Setting Example 4

■ Setting of GP-Pro EX

◆ Communication Settings

To display the setting screen, select [Device/PLC Settings] from [System setting window] in workspace.

Device/PLC 1 [Change Device/PLC](#)

Summary

Maker Driver Port

Text Data Mode [Change](#)

Communication Settings

SIO Type RS232C RS422/485(2wire) RS422/485(4wire)

Speed

Data Length 7 8

Parity NONE EVEN ODD

Stop Bit 1 2

Flow Control NONE ER(DTR/CTS) XON/XOFF

Timeout (sec)

Retry

Wait To Send (ms)

RI / VCC RI VCC

In the case of RS232C, you can select the 9th pin to RI (Input) or VCC (5V Power Supply). If you use the Digital's RS232C Isolation Unit, please select it to VCC.

Device-Specific Settings

Allowable No. of Device/PLCs: 16 Unit(s)

No.	Device Name	Settings
1	PLC1	Series=SDC20/21,Device Address=1

◆ Device Setting

To display the setting screen, click  ([Setting]) of the External Device you want to set from [Device-Specific Settings] of [Device/PLC Settings].



■ Settings of External Device

Use the ENT key, DISP key, down key and up key in front of the Controller for communication settings of the External Device. Please refer to the manual of the Controller for more details.

◆ Procedure

1. Press and hold the ENT key and the down key together (3 seconds or more) to display the setup items.
2. Press the down/up keys to select the setup items and press the ENT key.
3. Use the down/up keys to select the setup contents and press the ENT key.
4. Press the DISP key to move to the standard display.

◆ Setting Value

Setup Items	Setting Value
C31	1
C32	0
C33	0

NOTE

- Parameters to be set vary depending on the Controller. Please refer to the manual of the Controller for more details.

3.5 Setting Example 5

■ Setting of GP-Pro EX

◆ Communication Settings

To display the setting screen, select [Device/PLC Settings] from [System setting window] in workspace.

Device/PLC 1 [Change Device/PLC](#)

Summary

Maker Driver Port

Text Data Mode [Change](#)

Communication Settings

SIO Type RS232C RS422/485(2wire) RS422/485(4wire)

Speed

Data Length 7 8

Parity NONE EVEN ODD

Stop Bit 1 2

Flow Control NONE ER(DTR/CTS) XON/XOFF

Timeout (sec)

Retry

Wait To Send (ms)

RI / VCC RI VCC

In the case of RS232C, you can select the 9th pin to RI (Input) or VCC (5V Power Supply). If you use the Digital's RS232C Isolation Unit, please select it to VCC.

Device-Specific Settings

Allowable No. of Device/PLCs: 16 Unit(s)

No.	Device Name	Settings
1	PLC1	Series=SDC20/21,Device Address=1

◆ Device Setting

To display the setting screen, click  ([Setting]) of the External Device you want to set from [Device-Specific Settings] of [Device/PLC Settings].



■ Settings of External Device

Use the ENT key, DISP key, down key and up key in front of the Controller for communication settings of the External Device. Please refer to the manual of the Controller for more details.

◆ Procedure

1. Press and hold the ENT key and the down key together (3 seconds or more) to display the setup items.
2. Press the down/up keys to select the setup items and press the ENT key.
3. Use the down/up keys to select the setup contents and press the ENT key.
4. Press the DISP key to move to the standard display.

◆ Setting Value

Setup Items	Setting Value
C31	1
C32	0
C33	0

NOTE • Parameters to be set vary depending on the Controller. Please refer to the manual of the Controller for more details.

3.6 Setting Example 6

■ Setting of GP-Pro EX

◆ Communication Settings

To display the setting screen, select [Device/PLC Settings] from [System setting window] in workspace.

Device/PLC 1 [Change Device/PLC](#)

Summary

Maker Driver Port

Text Data Mode [Change](#)

Communication Settings

SIO Type RS232C RS422/485(2wire) RS422/485(4wire)

Speed

Data Length 7 8

Parity NONE EVEN ODD

Stop Bit 1 2

Flow Control NONE ER(DTR/DSR) XON/XOFF

Timeout (sec)

Retry

Wait To Send (ms)

RI / VCC RI VCC

In the case of RS232C, you can select the 9th pin to RI (Input) or VCC (5V Power Supply). If you use the Digital's RS232C Isolation Unit, please select it to VCC.

Device-Specific Settings

Allowable No. of Device/PLCs: 16 Unit(s)

No.	Device Name	Settings
1	PLC1	Series=SDC25/26,Device Address=1

◆ Device Setting

To display the setting screen, click  ([Setting]) of the External Device you want to set from [Device-Specific Settings] of [Device/PLC Settings].



■ Settings of External Device

Use the PARA key, mode key, enter key, down key and up key in front of the Controller for communication settings of the External Device. Please refer to the manual of the Controller for more details.

◆ Procedure

1. Press and hold the PARA key in operation display (2 seconds) to move to the bank selection display.
2. Press the enter key in the bank selection display to move to the bank setup display.
3. Press the PARA key several times to display the setup items.
4. Press the enter key to blink the display area of the setting value.
5. Use the down/up keys to select the setting contents.
6. Press the enter key to confirm the change.
7. Press the mode key to move to the operation display.

◆ Setting Value

Setup Items	Setting Value
C64	0
C65	1
C66	1
C67	1
C68	0
C69	0

NOTE

- Parameters to be set vary depending on the Controller. Please refer to the manual of the Controller for more details.

3.7 Setting Example 7

■ Setting of GP-Pro EX

◆ Communication Settings

To display the setting screen, select [Device/PLC Settings] from [System setting window] in workspace.

Device/PLC 1 [Change Device/PLC](#)

Summary

Maker Driver Port

Text Data Mode [Change](#)

Communication Settings

SIO Type RS232C RS422/485(2wire) RS422/485(4wire)

Speed

Data Length 7 8

Parity NONE EVEN ODD

Stop Bit 1 2

Flow Control NONE ER(DTR/CTS) XON/XOFF

Timeout (sec)

Retry

Wait To Send (ms)

RI / VCC RI VCC

In the case of RS232C, you can select the 9th pin to RI (Input) or VCC (5V Power Supply). If you use the Digital's RS232C Isolation Unit, please select it to VCC.

Device-Specific Settings

Allowable No. of Device/PLCs 16 Unit(s)

No.	Device Name	Settings
1	PLC1	Series=SDC30/31,Device Address=1

◆ Device Setting

To display the setting screen, click  ([Setting]) of the External Device you want to set from [Device-Specific Settings] of [Device/PLC Settings].



■ Settings of External Device

Use the ENT key, DISP key, MODE key, down key and up key in front of the Controller for communication settings of the External Device. You can change the communication setting only in the READY mode. Move the External Device to the READY mode before setting.

Please refer to the manual of the Controller for more details.

◆ Procedure

1. Press the MODE key twice in the standard display. When the RUN/READY mode switch display appears, change to the READY mode.
2. Press and hold the ENT key and the down key together (3 seconds or more) to display the setup items.
3. Press the down/up keys to select the setup items and press the ENT key.
4. Use the down/up keys to select the setup contents and press the ENT key.
5. Press the DISP key to move to the standard display.

◆ Setting Value

Setup Items	Setting Value
C31	1
C32	0
C33	0

NOTE • Parameters to be set vary depending on the Controller. Please refer to the manual of the Controller for more details.

3.8 Setting Example 8

■ Setting of GP-Pro EX

◆ Communication Settings

To display the setting screen, select [Device/PLC Settings] from [System setting window] in workspace.

Device/PLC 1 [Change Device/PLC](#)

Summary

Maker Driver Port

Text Data Mode [Change](#)

Communication Settings

SIO Type RS232C RS422/485(2wire) RS422/485(4wire)

Speed

Data Length 7 8

Parity NONE EVEN ODD

Stop Bit 1 2

Flow Control NONE ER(DTR/CTS) XON/XOFF

Timeout (sec)

Retry

Wait To Send (ms)

RI / VCC RI VCC

In the case of RS232C, you can select the 9th pin to RI (Input) or VCC (5V Power Supply). If you use the Digital's RS232C Isolation Unit, please select it to VCC.

Device-Specific Settings

Allowable No. of Device/PLCs 16 Unit(s)

No.	Device Name	Settings
1	PLC1	Series=SDC30/31,Device Address=1

◆ Device Setting

To display the setting screen, click  ([Setting]) of the External Device you want to set from [Device-Specific Settings] of [Device/PLC Settings].



■ Settings of External Device

Use the ENT key, DISP key, MODE key, down key and up key in front of the Controller for communication settings of the External Device. You can change the communication setting only in the READY mode. Move the External Device to the READY mode before setting.

Please refer to the manual of the Controller for more details.

◆ Procedure

1. Press the MODE key twice in the standard display. When the RUN/READY mode switch display appears, change to the READY mode.
2. Press and hold the ENT key and the down key together (3 seconds or more) to display the setup items.
3. Press the down/up keys to select the setup items and press the ENT key.
4. Use the down/up keys to select the setup contents and press the ENT key.
5. Press the DISP key to move to the standard display.

◆ Setting Value

Setup Items	Setting Value
C31	1
C32	0
C33	0

NOTE • Parameters to be set vary depending on the Controller. Please refer to the manual of the Controller for more details.

3.9 Setting Example 9

■ Setting of GP-Pro EX

◆ Communication Settings

To display the setting screen, select [Device/PLC Settings] from [System setting window] in workspace.

Device/PLC 1 [Change Device/PLC](#)

Summary

Maker Driver Port

Text Data Mode [Change](#)

Communication Settings

SIO Type RS232C RS422/485(2wire) RS422/485(4wire)

Speed

Data Length 7 8

Parity NONE EVEN ODD

Stop Bit 1 2

Flow Control NONE ER(DTR/CTS) XON/XOFF

Timeout (sec)

Retry

Wait To Send (ms)

RI / VCC RI VCC

In the case of RS232C, you can select the 9th pin to RI (Input) or VCC (5V Power Supply). If you use the Digital's RS232C Isolation Unit, please select it to VCC.

Device-Specific Settings

Allowable No. of Device/PLCs 16 Unit(s)

No.	Device Name	Settings
1	PLC1	Series=SDC35/36,Device Address=1

◆ Device Setting

To display the setting screen, click  ([Setting]) of the External Device you want to set from [Device-Specific Settings] of [Device/PLC Settings].



■ Settings of External Device

Use the PARA key, mode key, enter key, down key and up key in front of the Controller for communication settings of the External Device. Please refer to the manual of the Controller for more details.

◆ Procedure

1. Press and hold the PARA key in operation display (2 seconds) to move to the bank selection display.
2. Press the enter key in the bank selection display to move to the bank setup display.
3. Press the PARA key several times to display the setup items.
4. Press the enter key to blink the display area of the setting value.
5. Use the down/up keys to select the setting contents.
6. Press the enter key to confirm the change.
7. Press the mode key to move to the operation display.

◆ Setting Value

Setup Items	Setting Value
C64	0
C65	1
C66	1
C67	1
C68	0
C69	0

NOTE

- Parameters to be set vary depending on the Controller. Please refer to the manual of the Controller for more details.

3.10 Setting Example 10

■ Setting of GP-Pro EX

◆ Communication Settings

To display the setting screen, select [Device/PLC Settings] from [System setting window] in workspace.

Device/PLC 1 [Change Device/PLC](#)

Summary

Maker Driver Port

Text Data Mode [Change](#)

Communication Settings

SIO Type RS232C RS422/485(2wire) RS422/485(4wire)

Speed

Data Length 7 8

Parity NONE EVEN ODD

Stop Bit 1 2

Flow Control NONE ER(DTR/DSR) XON/XOFF

Timeout (sec)

Retry

Wait To Send (ms)

RI / VCC RI VCC

In the case of RS232C, you can select the 9th pin to RI (Input) or VCC (5V Power Supply). If you use the Digital's RS232C Isolation Unit, please select it to VCC.

Device-Specific Settings

Allowable No. of Device/PLCs: 16 Unit(s)

No.	Device Name	Settings
1	PLC1	Series=SDC40A,Device Address=1

◆ Device Setting

To display the setting screen, click  ([Setting]) of the External Device you want to set from [Device-Specific Settings] of [Device/PLC Settings].



■ Settings of External Device

Use the PARA key, ENT key, DISP key, down key and up key in front of the Controller for communication settings of the External Device. You can change the communication setting only in the READY mode. Move the External Device to the READY mode before setting.

Please refer to the manual of the Controller for more details.

◆ Procedure

1. Press the PARA key in the standard display to display PARA. Next, press the ENT key to display rrry and move to the READY mode.
2. Press the PARA key several times in the standard display to display SETUP.
3. Press the ENT key to display the setup items.
4. Press the down/up keys to select the setup items and press the ENT key.
5. Use the down/up keys to select the setup contents and press the ENT key.
6. Press the DISP key to move to the standard display.

◆ Setting Value

Setup Items	Setting Value
C84	1
C85	0

NOTE • Parameters to be set vary depending on the Controller. Please refer to the manual of the Controller for more details.

3.11 Setting Example 11

■ Setting of GP-Pro EX

◆ Communication Settings

To display the setting screen, select [Device/PLC Settings] from [System setting window] in workspace.

Device/PLC 1 [Change Device/PLC](#)

Summary

Maker Driver Port

Text Data Mode [Change](#)

Communication Settings

SIO Type RS232C RS422/485(2wire) RS422/485(4wire)

Speed

Data Length 7 8

Parity NONE EVEN ODD

Stop Bit 1 2

Flow Control NONE ER(DTR/DSR) XON/XOFF

Timeout (sec)

Retry

Wait To Send (ms)

RI / VCC RI VCC

In the case of RS232C, you can select the 9th pin to RI (Input) or VCC (5V Power Supply). If you use the Digital's RS232C Isolation Unit, please select it to VCC.

Device-Specific Settings

Allowable No. of Device/PLCs: 16 Unit(s)

No.	Device Name	Settings
1	PLC1	Series=SDC40A,Device Address=1

◆ Device Setting

To display the setting screen, click  ([Setting]) of the External Device you want to set from [Device-Specific Settings] of [Device/PLC Settings].



■ Settings of External Device

Use the PARA key, ENT key, DISP key, down key and up key in front of the Controller for communication settings of the External Device. You can change the communication setting only in the READY mode. Move the External Device to the READY mode before setting.

Please refer to the manual of the Controller for more details.

◆ Procedure

1. Press the PARA key in the standard display to display PARA. Next, press the ENT key to display rrry and move to the READY mode.
2. Press the PARA key several times in the standard display to display SETUP.
3. Press the ENT key to display the setup items.
4. Press the down/up keys to select the setup items and press the ENT key.
5. Use the down/up keys to select the setup contents and press the ENT key.
6. Press the DISP key to move to the standard display.

◆ Setting Value

Setup Items	Setting Value
C84	1
C85	0

NOTE • Parameters to be set vary depending on the Controller. Please refer to the manual of the Controller for more details.

3.12 Setting Example 12

■ Setting of GP-Pro EX

◆ Communication Settings

To display the setting screen, select [Device/PLC Settings] from [System setting window] in workspace.

Device/PLC 1 [Change Device/PLC](#)

Summary

Maker Driver Port

Text Data Mode [Change](#)

Communication Settings

SIO Type RS232C RS422/485(2wire) RS422/485(4wire)

Speed

Data Length 7 8

Parity NONE EVEN ODD

Stop Bit 1 2

Flow Control NONE ER(DTR/CTS) XON/XOFF

Timeout (sec)

Retry

Wait To Send (ms)

RI / VCC RI VCC

In the case of RS232C, you can select the 9th pin to RI (Input) or VCC (5V Power Supply). If you use the Digital's RS232C Isolation Unit, please select it to VCC.

Device-Specific Settings

Allowable No. of Device/PLCs 16 Unit(s)

No.	Device Name	Settings
1	PLC1	Series=SDC40A,Device Address=1

◆ Device Setting

To display the setting screen, click  ([Setting]) of the External Device you want to set from [Device-Specific Settings] of [Device/PLC Settings].



■ Settings of External Device

Use the PARA key, ENT key, DISP key, down key and up key in front of the Controller for communication settings of the External Device. You can change the communication setting only in the READY mode. Move the External Device to the READY mode before setting.

Please refer to the manual of the Controller for more details.

◆ Procedure

1. Press the PARA key in the standard display to display PARA. Next, press the ENT key to display rrry and move to the READY mode.
2. Press the PARA key several times in the standard display to display SETUP.
3. Press the ENT key to display the setup items.
4. Press the down/up keys to select the setup items and press the ENT key.
5. Use the down/up keys to select the setup contents and press the ENT key.
6. Press the DISP key to move to the standard display.

◆ Setting Value

Setup Items	Setting Value
C84	1
C85	0

NOTE

- Parameters to be set vary depending on the Controller. Please refer to the manual of the Controller for more details.

3.13 Setting Example 13

■ Setting of GP-Pro EX

◆ Communication Settings

To display the setting screen, select [Device/PLC Settings] from [System setting window] in workspace.

Device/PLC 1 [Change Device/PLC](#)

Summary

Maker Driver Port

Text Data Mode [Change](#)

Communication Settings

SIO Type RS232C RS422/485(2wire) RS422/485(4wire)

Speed

Data Length 7 8

Parity NONE EVEN ODD

Stop Bit 1 2

Flow Control NONE ER(DTR/CTS) XON/XOFF

Timeout (sec)

Retry

Wait To Send (ms)

RI / VCC RI VCC

In the case of RS232C, you can select the 9th pin to RI (Input) or VCC (5V Power Supply). If you use the Digital's RS232C Isolation Unit, please select it to VCC.

Device-Specific Settings

Allowable No. of Device/PLCs 16 Unit(s)

No.	Device Name	Settings
1	PLC1	Series=SDC40B,Device Address=1

◆ Device Setting

To display the setting screen, click  ([Setting]) of the External Device you want to set from [Device-Specific Settings] of [Device/PLC Settings].



■ Settings of External Device

Use the PARA key, ENT key, DISP key, down key and up key in front of the Controller for communication settings of the External Device. Please refer to the manual of the Controller for more details.

◆ Procedure

1. Press the PARA key in the standard display to move to the setup mode.
2. Press the ENT key to display the setup items.
3. Press the down/up keys to select the setup items and press the ENT key.
4. Use the down/up keys to select the setup contents and press the ENT key.
5. Press the DISP key to move to the standard display.

◆ Setting Value

Setup Items	Setting Value
C25	1
C26	0
C27	0

NOTE • Parameters to be set vary depending on the Controller. Please refer to the manual of the Controller for more details.

3.14 Setting Example 14

■ Setting of GP-Pro EX

◆ Communication Settings

To display the setting screen, select [Device/PLC Settings] from [System setting window] in workspace.

Device/PLC 1 [Change Device/PLC](#)

Summary

Maker Driver Port

Text Data Mode [Change](#)

Communication Settings

SIO Type RS232C RS422/485(2wire) RS422/485(4wire)

Speed

Data Length 7 8

Parity NONE EVEN ODD

Stop Bit 1 2

Flow Control NONE ER(DTR/CTS) XON/XOFF

Timeout (sec)

Retry

Wait To Send (ms)

RI / VCC RI VCC

In the case of RS232C, you can select the 9th pin to RI (Input) or VCC (5V Power Supply). If you use the Digital's RS232C Isolation Unit, please select it to VCC.

Device-Specific Settings

Allowable No. of Device/PLCs 16 Unit(s)

No.	Device Name	Settings
1	PLC1	Series=SDC40B,Device Address=1

◆ Device Setting

To display the setting screen, click  ([Setting]) of the External Device you want to set from [Device-Specific Settings] of [Device/PLC Settings].



■ Settings of External Device

Use the PARA key, ENT key, DISP key, down key and up key in front of the Controller for communication settings of the External Device. Please refer to the manual of the Controller for more details.

◆ Procedure

1. Press the PARA key in the standard display to move to the setup mode.
2. Press the ENT key to display the setup items.
3. Press the down/up keys to select the setup items and press the ENT key.
4. Use the down/up keys to select the setup contents and press the ENT key.
5. Press the DISP key to move to the standard display.

◆ Setting Value

Setup Items	Setting Value
C25	1
C26	0
C27	0

NOTE

- Parameters to be set vary depending on the Controller. Please refer to the manual of the Controller for more details.

3.15 Setting Example 15

■ Setting of GP-Pro EX

◆ Communication Settings

To display the setting screen, select [Device/PLC Settings] from [System setting window] in workspace.

Device/PLC 1 [Change Device/PLC](#)

Summary

Maker Driver Port

Text Data Mode [Change](#)

Communication Settings

SIO Type RS232C RS422/485(2wire) RS422/485(4wire)

Speed

Data Length 7 8

Parity NONE EVEN ODD

Stop Bit 1 2

Flow Control NONE ER(DTR/CTS) XON/XOFF

Timeout (sec)

Retry

Wait To Send (ms)

RI / VCC RI VCC

In the case of RS232C, you can select the 9th pin to RI (Input) or VCC (5V Power Supply). If you use the Digital's RS232C Isolation Unit, please select it to VCC.

Device-Specific Settings

Allowable No. of Device/PLCs: 16 Unit(s)

No.	Device Name	Settings
1	PLC1	Series=SDC40B,Device Address=1

◆ Device Setting

To display the setting screen, click  ([Setting]) of the External Device you want to set from [Device-Specific Settings] of [Device/PLC Settings].



■ Settings of External Device

Use the PARA key, ENT key, DISP key, down key and up key in front of the Controller for communication settings of the External Device. Please refer to the manual of the Controller for more details.

◆ Procedure

1. Press the PARA key in the standard display to move to the setup mode.
2. Press the ENT key to display the setup items.
3. Press the down/up keys to select the setup items and press the ENT key.
4. Use the down/up keys to select the setup contents and press the ENT key.
5. Press the DISP key to move to the standard display.

◆ Setting Value

Setup Items	Setting Value
C25	1
C26	0
C27	0

NOTE

- Parameters to be set vary depending on the Controller. Please refer to the manual of the Controller for more details.

3.16 Setting Example 16

■ Setting of GP-Pro EX

◆ Communication Settings

To display the setting screen, select [Device/PLC Settings] from [System setting window] in workspace.

Device/PLC 1

Summary [Change Device/PLC](#)

Maker Yamatake Corporation Driver Digital Controller SIO Port COM1

Text Data Mode 1 [Change](#)

Communication Settings

SIO Type RS232C RS422/485(2wire) RS422/485(4wire)

Speed 9600

Data Length 7 8

Parity NONE EVEN ODD

Stop Bit 1 2

Flow Control NONE ER(DTR/DSR) XON/XOFF

Timeout 4 (sec)

Retry 2

Wait To Send 10 (ms)

RI / VCC RI VCC

In the case of RS232C, you can select the 9th pin to RI (Input) or VCC (5V Power Supply). If you use the Digital's RS232C Isolation Unit, please select it to VCC.

[Default](#)

Device-Specific Settings

Allowable No. of Device/PLCs 16 Unit(s)

No.	Device Name	Settings
1	PLC1	Series=SDC40G,Device Address=1

◆ Device Setting

To display the setting screen, click  ([Setting]) of the External Device you want to set from [Device-Specific Settings] of [Device/PLC Settings].



■ Settings of External Device

Use the PARA key, ENT key, DISP key, down key and up key in front of the Controller for communication settings of the External Device. You can change the communication setting only in the READY mode. Move the External Device to the READY mode before setting.

Please refer to the manual of the Controller for more details.

◆ Procedure

1. Press the PARA key in the standard display to display PARA. Next, press the ENT key to display rrry and move to the READY mode.
2. Press the PARA key several times in the standard display to display SETUP.
3. Press the ENT key to display the setup items.
4. Press the down/up keys to select the setup items and press the ENT key.
5. Use the down/up keys to select the setup contents and press the ENT key.
6. Press the DISP key to move to the standard display.

◆ Setting Value

Setup Items	Setting Value
C25	1
C26	0
C27	0

NOTE

- Parameters to be set vary depending on the Controller. Please refer to the manual of the Controller for more details.

3.17 Setting Example 17

■ Setting of GP-Pro EX

◆ Communication Settings

To display the setting screen, select [Device/PLC Settings] from [System setting window] in workspace.

Device/PLC 1 [Change Device/PLC](#)

Summary

Maker Driver Port

Text Data Mode [Change](#)

Communication Settings

SIO Type RS232C RS422/485(2wire) RS422/485(4wire)

Speed

Data Length 7 8

Parity NONE EVEN ODD

Stop Bit 1 2

Flow Control NONE ER(DTR/CTS) XON/XOFF

Timeout (sec)

Retry

Wait To Send (ms)

RI / VCC RI VCC

In the case of RS232C, you can select the 9th pin to RI (Input) or VCC (5V Power Supply). If you use the Digital's RS232C Isolation Unit, please select it to VCC.

Device-Specific Settings

Allowable No. of Device/PLCs 16 Unit(s)

No.	Device Name	Settings
1	PLC1	Series=SDC40G,Device Address=1

◆ Device Setting

To display the setting screen, click  ([Setting]) of the External Device you want to set from [Device-Specific Settings] of [Device/PLC Settings].



■ Settings of External Device

Use the PARA key, ENT key, DISP key, down key and up key in front of the Controller for communication settings of the External Device. You can change the communication setting only in the READY mode. Move the External Device to the READY mode before setting.

Please refer to the manual of the Controller for more details.

◆ Procedure

1. Press the PARA key in the standard display to display PARA. Next, press the ENT key to display rrry and move to the READY mode.
2. Press the PARA key several times in the standard display to display SETUP.
3. Press the ENT key to display the setup items.
4. Press the down/up keys to select the setup items and press the ENT key.
5. Use the down/up keys to select the setup contents and press the ENT key.
6. Press the DISP key to move to the standard display.

◆ Setting Value

Setup Items	Setting Value
C25	1
C26	0
C27	0

NOTE • Parameters to be set vary depending on the Controller. Please refer to the manual of the Controller for more details.

3.18 Setting Example 18

■ Setting of GP-Pro EX

◆ Communication Settings

To display the setting screen, select [Device/PLC Settings] from [System setting window] in workspace.

Device/PLC 1 [Change Device/PLC](#)

Summary

Maker Driver Port

Text Data Mode [Change](#)

Communication Settings

SIO Type RS232C RS422/485(2wire) RS422/485(4wire)

Speed

Data Length 7 8

Parity NONE EVEN ODD

Stop Bit 1 2

Flow Control NONE ER(DTR/CTS) XON/XOFF

Timeout (sec)

Retry

Wait To Send (ms)

RI / VCC RI VCC

In the case of RS232C, you can select the 9th pin to RI (Input) or VCC (5V Power Supply). If you use the Digital's RS232C Isolation Unit, please select it to VCC.

Device-Specific Settings

Allowable No. of Device/PLCs: 16 Unit(s)

No.	Device Name	Settings
1	PLC1	Series=DMC10,Device Address=1

◆ Device Setting

To display the setting screen, click  ([Setting]) of the External Device you want to set from [Device-Specific Settings] of [Device/PLC Settings].



■ Settings of External Device

Use the ladder software for communication setting of the External Device. (Operation confirmed using SLP-D10 V3.0.1) Set the device address of the External Device with the rotary switch on the front of the Controller. Please refer to the manual of the Controller for more details.

◆ Procedure

1. Set the device address with the rotary switch for the device address on the front of the Controller.
After setting, turn ON the power of the External Device again.
2. Click [Set] with the ladder software to display the setting screen.
3. Click [Model Setting] from the menu to select the model No. of the External Device.
4. Click [Environmental Setting] from the menu to perform the setup transfer setting.
5. Select [Communication] from [Basic Function] in the tree view to set the communication.
6. Transfer the setting to the External Device.

When writing is completed, turn on the power of the External Device again.

◆ Setting Value

Setup Items	Setting Value
Line Speed	3
Data Format	0
Communication Minimum Response Time	1
Value including communication minimum response time	0
CPL/MODBUSswitch	0
Memory Protect	0

NOTE

- Parameters to be set vary depending on the Controller. Please refer to the manual of the Controller for more details.

3.19 Setting Example 19

■ Setting of GP-Pro EX

◆ Communication Settings

To display the setting screen, select [Device/PLC Settings] from [System setting window] in workspace.

Device/PLC 1 [Change Device/PLC](#)

Summary

Maker Driver Port

Text Data Mode [Change](#)

Communication Settings

SIO Type RS232C RS422/485(2wire) RS422/485(4wire)

Speed

Data Length 7 8

Parity NONE EVEN ODD

Stop Bit 1 2

Flow Control NONE ER(DTR/CTS) XON/XOFF

Timeout (sec)

Retry

Wait To Send (ms)

RI / VCC RI VCC

In the case of RS232C, you can select the 9th pin to RI (Input) or VCC (5V Power Supply). If you use the Digital's RS232C Isolation Unit, please select it to VCC.

Device-Specific Settings

Allowable No. of Device/PLCs 16 Unit(s)

No.	Device Name	Settings
1	PLC1	Series=DCP31,Device Address=1

◆ Device Setting

To display the setting screen, click  ([Setting]) of the External Device you want to set from [Device-Specific Settings] of [Device/PLC Settings].



■ Settings of External Device

Use the FUNC key, PARA key, ENT key, DISP key, down key and up key in front of the Controller for communication settings of the External Device. Please refer to the manual of the Controller for more details.

◆ Procedure

1. While pressing the FUNC key, press the PARA key to move to the screen of the setting group selection.
2. Press the PARA key several times to display the setup data setting group, and press the ENT key.
3. Press the down/up keys several times to select the setup items and press the ENT key.
4. Use the down/up keys to select the setup contents and press the ENT key.
5. Press the DISP key to move to the standard display.

◆ Setting Value

Setup Items	Setting Value
C84	1
C85	0
C93	0

NOTE

- Parameters to be set vary depending on the Controller. Please refer to the manual of the Controller for more details.

3.20 Setting Example 20

■ Setting of GP-Pro EX

◆ Communication Settings

To display the setting screen, select [Device/PLC Settings] from [System setting window] in workspace.

Device/PLC 1 [Change Device/PLC](#)

Summary

Maker Driver Port

Text Data Mode [Change](#)

Communication Settings

SIO Type RS232C RS422/485(2wire) RS422/485(4wire)

Speed

Data Length 7 8

Parity NONE EVEN ODD

Stop Bit 1 2

Flow Control NONE ER(DTR/CTS) XON/XOFF

Timeout (sec)

Retry

Wait To Send (ms)

RI / VCC RI VCC

In the case of RS232C, you can select the 9th pin to RI (Input) or VCC (5V Power Supply). If you use the Digital's RS232C Isolation Unit, please select it to VCC.

Device-Specific Settings

Allowable No. of Device/PLCs 16 Unit(s)

No.	Device Name	Settings
1	PLC1	Series=DCP31,Device Address=1

◆ Device Setting

To display the setting screen, click  ([Setting]) of the External Device you want to set from [Device-Specific Settings] of [Device/PLC Settings].



■ Settings of External Device

Use the FUNC key, PARA key, ENT key, DISP key, down key and up key in front of the Controller for communication settings of the External Device. Please refer to the manual of the Controller for more details.

◆ Procedure

1. While pressing the FUNC key, press the PARA key to move to the screen of the setting group selection.
2. Press the PARA key several times to display the setup data setting group, and press the ENT key.
3. Press the down/up keys several times to select the setup items and press the ENT key.
4. Use the down/up keys to select the setup contents and press the ENT key.
5. Press the DISP key to move to the standard display.

◆ Setting Value

Setup Items	Setting Value
C84	1
C85	0
C93	0

NOTE

- Parameters to be set vary depending on the Controller. Please refer to the manual of the Controller for more details.

3.21 Setting Example 21

■ Setting of GP-Pro EX

◆ Communication Settings

To display the setting screen, select [Device/PLC Settings] from [System setting window] in workspace.

Device/PLC 1 [Change Device/PLC](#)

Summary

Maker Driver Port

Text Data Mode [Change](#)

Communication Settings

SIO Type RS232C RS422/485(2wire) RS422/485(4wire)

Speed

Data Length 7 8

Parity NONE EVEN ODD

Stop Bit 1 2

Flow Control NONE ER(DTR/CTS) XON/XOFF

Timeout (sec)

Retry

Wait To Send (ms)

RI / VCC RI VCC

In the case of RS232C, you can select the 9th pin to RI (Input) or VCC (5V Power Supply). If you use the Digital's RS232C Isolation Unit, please select it to VCC.

Device-Specific Settings

Allowable No. of Device/PLCs 16 Unit(s)

No.	Device Name	Settings
<input type="button" value="Delete"/> 1	<input type="text" value="PLC1"/>	<input type="text" value="Series=DCP32,Device Address=1"/>

◆ Device Setting

To display the setting screen, click  ([Setting]) of the External Device you want to set from [Device-Specific Settings] of [Device/PLC Settings].

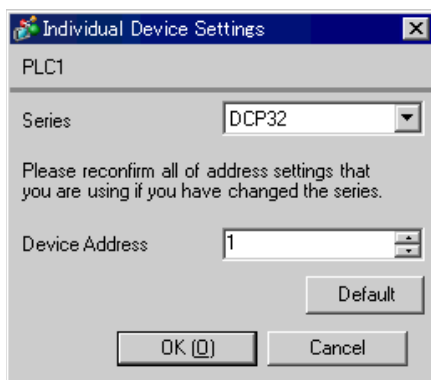

■ Settings of External Device

Use the FUNC key, PARA key, ENT key, DISP key, down key and up key in front of the Controller for communication settings of the External Device. Please refer to the manual of the Controller for more details.

◆ Procedure

1. While pressing the FUNC key, press the PARA key to move to the screen of the setting group selection.
2. Press the PARA key several times to display the setup data setting group, and press the ENT key.
3. Press the down/up keys several times to select the setup items and press the ENT key.
4. Use the down/up keys to select the setup contents and press the ENT key.
5. Press the DISP key to move to the standard display.

◆ Setting Value

Setup Items	Setting Value
C84	1
C85	0
C93	0

NOTE • Parameters to be set vary depending on the Controller. Please refer to the manual of the Controller for more details.

3.22 Setting Example 22

■ Setting of GP-Pro EX

◆ Communication Settings

To display the setting screen, select [Device/PLC Settings] from [System setting window] in workspace.

Device/PLC 1 [Change Device/PLC](#)

Summary

Maker Driver Port

Text Data Mode [Change](#)

Communication Settings

SIO Type RS232C RS422/485(2wire) RS422/485(4wire)

Speed

Data Length 7 8

Parity NONE EVEN ODD

Stop Bit 1 2

Flow Control NONE ER(DTR/CTS) XON/XOFF

Timeout (sec)

Retry

Wait To Send (ms)

RI / VCC RI VCC

In the case of RS232C, you can select the 9th pin to RI (Input) or VCC (5V Power Supply). If you use the Digital's RS232C Isolation Unit, please select it to VCC.

Device-Specific Settings

Allowable No. of Device/PLCs 16 Unit(s)

No.	Device Name	Settings
1	PLC1	Series=DCP32,Device Address=1

◆ Device Setting

To display the setting screen, click  ([Setting]) of the External Device you want to set from [Device-Specific Settings] of [Device/PLC Settings].



■ Settings of External Device

Use the FUNC key, PARA key, ENT key, DISP key, down key and up key in front of the Controller for communication settings of the External Device. Please refer to the manual of the Controller for more details.

◆ Procedure

1. While pressing the FUNC key, press the PARA key to move to the screen of the setting group selection.
2. Press the PARA key several times to display the setup data setting group, and press the ENT key.
3. Press the down/up keys several times to select the setup items and press the ENT key.
4. Use the down/up keys to select the setup contents and press the ENT key.
5. Press the DISP key to move to the standard display.

◆ Setting Value

Setup Items	Setting Value
C84	1
C85	0
C93	0

NOTE • Parameters to be set vary depending on the Controller. Please refer to the manual of the Controller for more details.

3.23 Setting Example 23

■ Setting of GP-Pro EX

◆ Communication Settings

To display the setting screen, select [Device/PLC Settings] from [System setting window] in workspace.

Device/PLC 1 [Change Device/PLC](#)

Summary

Maker Driver Port

Text Data Mode [Change](#)

Communication Settings

SIO Type RS232C RS422/485(2wire) RS422/485(4wire)

Speed

Data Length 7 8

Parity NONE EVEN ODD

Stop Bit 1 2

Flow Control NONE ER(DTR/CTS) XON/XOFF

Timeout (sec)

Retry

Wait To Send (ms)

RI / VCC RI VCC

In the case of RS232C, you can select the 9th pin to RI (Input) or VCC (5V Power Supply). If you use the Digital's RS232C Isolation Unit, please select it to VCC.

Device-Specific Settings

Allowable No. of Device/PLCs 16 Unit(s)

No.	Device Name	Settings
1	PLC1	Series=DCP551,Device Address=1

◆ Device Setting

To display the setting screen, click  ([Setting]) of the External Device you want to set from [Device-Specific Settings] of [Device/PLC Settings].

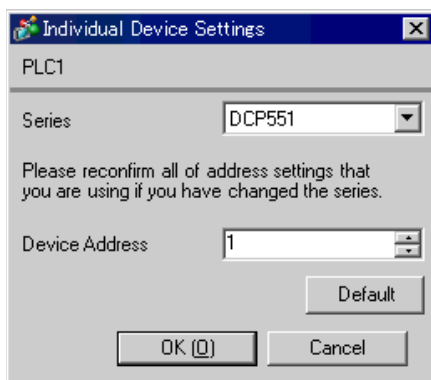

■ Settings of External Device

Use the PROG key, RUN/HOLD key, SETUP key, ENT key, DISP key, down key and up key in front of the Controller for communication settings of the External Device. You can change the communication setting only in the READY mode. Move the External Device to the READY mode before setting.

Please refer to the manual of the Controller for more details.

◆ Procedure

1. Press the RUN/HOLD key while pressing the PROG key to move to the READY mode.
2. Press the SETUP key in the standard display to move to the setup mode.
3. Press the down/up keys several times to select the setup items and press the ENT key.
4. Use the down/up keys to select the setup contents and press the ENT key.
5. Press the DISP key to move to the standard display.

◆ Setting Value

Setup Items	Setting Value
C76	1
C77	0
C78	0
C79	0
C80	1
C97	0

NOTE

- Parameters to be set vary depending on the Controller. Please refer to the manual of the Controller for more details.

3.24 Setting Example 24

■ Setting of GP-Pro EX

◆ Communication Settings

To display the setting screen, select [Device/PLC Settings] from [System setting window] in workspace.

Device/PLC 1 [Change Device/PLC](#)

Summary

Maker Driver Port

Text Data Mode [Change](#)

Communication Settings

SIO Type RS232C RS422/485(2wire) RS422/485(4wire)

Speed

Data Length 7 8

Parity NONE EVEN ODD

Stop Bit 1 2

Flow Control NONE ER(DTR/CTS) XON/XOFF

Timeout (sec)

Retry

Wait To Send (ms)

RI / VCC RI VCC

In the case of RS232C, you can select the 9th pin to RI (Input) or VCC (5V Power Supply). If you use the Digital's RS232C Isolation Unit, please select it to VCC.

Device-Specific Settings

Allowable No. of Device/PLCs 16 Unit(s)

No.	Device Name	Settings
1	PLC1	Series=DCP551,Device Address=1

◆ Device Setting

To display the setting screen, click  ([Setting]) of the External Device you want to set from [Device-Specific Settings] of [Device/PLC Settings].

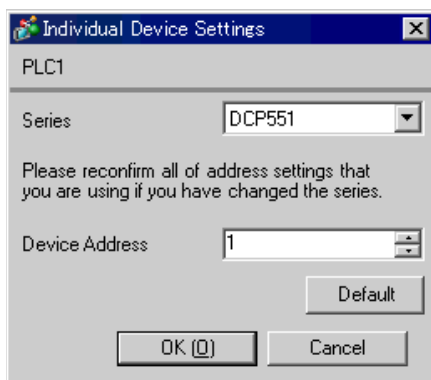

■ Settings of External Device

Use the PROG key, RUN/HOLD key, SETUP key, ENT key, DISP key, down key and up key in front of the Controller for communication settings of the External Device. You can change the communication setting only in the READY mode. Move the External Device to the READY mode before setting.

Please refer to the manual of the Controller for more details.

◆ Procedure

1. Press the RUN/HOLD key while pressing the PROG key to move to the READY mode.
2. Press the SETUP key in the standard display to move to the setup mode.
3. Press the down/up keys several times to select the setup items and press the ENT key.
4. Use the down/up keys to select the setup contents and press the ENT key.
5. Press the DISP key to move to the standard display.

◆ Setting Value

Setup Items	Setting Value
C76	1
C77	0
C78	0
C79	0
C80	0
C97	0

NOTE

- Parameters to be set vary depending on the Controller. Please refer to the manual of the Controller for more details.

3.25 Setting Example 25

■ Setting of GP-Pro EX

◆ Communication Settings

To display the setting screen, select [Device/PLC Settings] from [System setting window] in workspace.

Device/PLC 1 [Change Device/PLC](#)

Summary

Maker Driver Port

Text Data Mode [Change](#)

Communication Settings

SIO Type RS232C RS422/485(2wire) RS422/485(4wire)

Speed

Data Length 7 8

Parity NONE EVEN ODD

Stop Bit 1 2

Flow Control NONE ER(DTR/DSR) XON/XOFF

Timeout (sec)

Retry

Wait To Send (ms)

RI / VCC RI VCC

In the case of RS232C, you can select the 9th pin to RI (Input) or VCC (5V Power Supply). If you use the Digital's RS232C Isolation Unit, please select it to VCC.

Device-Specific Settings

Allowable No. of Device/PLCs: 16 Unit(s)

No.	Device Name	Settings
1	PLC1	Series=DCP551,Device Address=1

◆ Device Setting

To display the setting screen, click  ([Setting]) of the External Device you want to set from [Device-Specific Settings] of [Device/PLC Settings].



■ Settings of External Device

Use the PROG key, RUN/HOLD key, SETUP key, ENT key, DISP key, down key and up key in front of the Controller for communication settings of the External Device. You can change the communication setting only in the READY mode. Move the External Device to the READY mode before setting.

Please refer to the manual of the Controller for more details.

◆ Procedure

1. Press the RUN/HOLD key while pressing the PROG key to move to the READY mode.
2. Press the SETUP key in the standard display to move to the setup mode.
3. Press the down/up keys several times to select the setup items and press the ENT key.
4. Use the down/up keys to select the setup contents and press the ENT key.
5. Press the DISP key to move to the standard display.

◆ Setting Value

Setup Items	Setting Value
C76	1
C77	0
C78	0
C79	0
C80	0
C97	0

NOTE

- Parameters to be set vary depending on the Controller. Please refer to the manual of the Controller for more details.

3.26 Setting Example 26

■ Setting of GP-Pro EX

◆ Communication Settings

To display the setting screen, select [Device/PLC Settings] from [System setting window] in workspace.

Device/PLC 1

Summary [Change Device/PLC](#)

Maker Driver Port

Text Data Mode [Change](#)

Communication Settings

SIO Type RS232C RS422/485(2wire) RS422/485(4wire)

Speed

Data Length 7 8

Parity NONE EVEN ODD

Stop Bit 1 2

Flow Control NONE ER(DTR/CTS) XON/XOFF

Timeout (sec)

Retry

Wait To Send (ms)

RI / VCC RI VCC

In the case of RS232C, you can select the 9th pin to RI (Input) or VCC (5V Power Supply). If you use the Digital's RS232C Isolation Unit, please select it to VCC.

[Default](#)

Device-Specific Settings

Allowable No. of Device/PLCs 16 Unit(s)

No.	Device Name	Settings
1	PLC1	Series=DCP552,Device Address=1

◆ Device Setting

To display the setting screen, click  ([Setting]) of the External Device you want to set from [Device-Specific Settings] of [Device/PLC Settings].

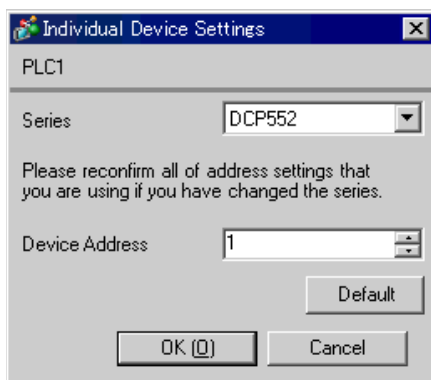

■ Settings of External Device

Use the PROG key, RUN/HOLD key, SETUP key, ENT key, DISP key, down key and up key in front of the Controller for communication settings of the External Device. You can change the communication setting only in the READY mode. Move the External Device to the READY mode before setting.

Please refer to the manual of the Controller for more details.

◆ Procedure

1. Press the RUN/HOLD key while pressing the PROG key to move to the READY mode.
2. Press the SETUP key in the standard display to move to the setup mode.
3. Press the down/up keys several times to select the setup items and press the ENT key.
4. Use the down/up keys to select the setup contents and press the ENT key.
5. Press the DISP key to move to the standard display.

◆ Setting Value

Setup Items	Setting Value
C76	1
C77	0
C78	0
C79	0
C80	1
C97	0

NOTE

- Parameters to be set vary depending on the Controller. Please refer to the manual of the Controller for more details.

3.27 Setting Example 27

■ Setting of GP-Pro EX

◆ Communication Settings

To display the setting screen, select [Device/PLC Settings] from [System setting window] in workspace.

Device/PLC 1 [Change Device/PLC](#)

Summary

Maker Driver Port

Text Data Mode [Change](#)

Communication Settings

SIO Type RS232C RS422/485(2wire) RS422/485(4wire)

Speed

Data Length 7 8

Parity NONE EVEN ODD

Stop Bit 1 2

Flow Control NONE ER(DTR/CTS) XON/XOFF

Timeout (sec)

Retry

Wait To Send (ms)

RI / VCC RI VCC

In the case of RS232C, you can select the 9th pin to RI (Input) or VCC (5V Power Supply). If you use the Digital's RS232C Isolation Unit, please select it to VCC.

Device-Specific Settings

Allowable No. of Device/PLCs 16 Unit(s)

No.	Device Name	Settings
1	PLC1	Series=DCP552,Device Address=1

◆ Device Setting

To display the setting screen, click  ([Setting]) of the External Device you want to set from [Device-Specific Settings] of [Device/PLC Settings].

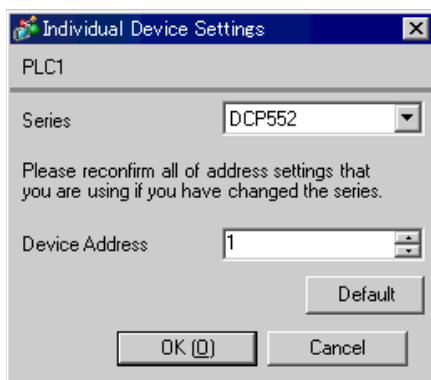

■ Settings of External Device

Use the PROG key, RUN/HOLD key, SETUP key, ENT key, DISP key, down key and up key in front of the Controller for communication settings of the External Device. You can change the communication setting only in the READY mode. Move the External Device to the READY mode before setting.

Please refer to the manual of the Controller for more details.

◆ Procedure

1. Press the RUN/HOLD key while pressing the PROG key to move to the READY mode.
2. Press the SETUP key in the standard display to move to the setup mode.
3. Press the down/up keys several times to select the setup items and press the ENT key.
4. Use the down/up keys to select the setup contents and press the ENT key.
5. Press the DISP key to move to the standard display.

◆ Setting Value

Setup Items	Setting Value
C76	1
C77	0
C78	0
C79	0
C80	0
C97	0

NOTE

- Parameters to be set vary depending on the Controller. Please refer to the manual of the Controller for more details.

3.28 Setting Example 28

■ Setting of GP-Pro EX

◆ Communication Settings

To display the setting screen, select [Device/PLC Settings] from [System setting window] in workspace.

Device/PLC 1

Summary [Change Device/PLC](#)

Maker Driver Port

Text Data Mode [Change](#)

Communication Settings

SIO Type RS232C RS422/485(2wire) RS422/485(4wire)

Speed

Data Length 7 8

Parity NONE EVEN ODD

Stop Bit 1 2

Flow Control NONE ER(DTR/CTS) XON/XOFF

Timeout (sec)

Retry

Wait To Send (ms)

RI / VCC RI VCC

In the case of RS232C, you can select the 9th pin to RI (Input) or VCC (5V Power Supply). If you use the Digital's RS232C Isolation Unit, please select it to VCC.

Device-Specific Settings

Allowable No. of Device/PLCs 16 Unit(s)

No.	Device Name	Settings
1	PLC1	Series=DCP552,Device Address=1

◆ Device Setting

To display the setting screen, click  ([Setting]) of the External Device you want to set from [Device-Specific Settings] of [Device/PLC Settings].

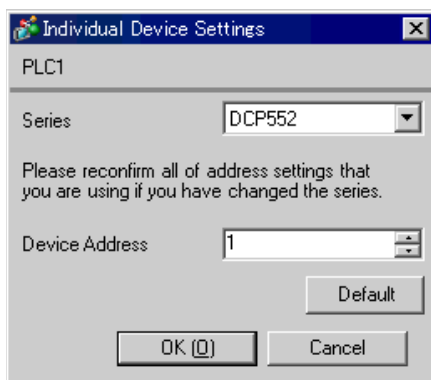

■ Settings of External Device

Use the PROG key, RUN/HOLD key, SETUP key, ENT key, DISP key, down key and up key in front of the Controller for communication settings of the External Device. You can change the communication setting only in the READY mode. Move the External Device to the READY mode before setting.

Please refer to the manual of the Controller for more details.

◆ Procedure

1. Press the RUN/HOLD key while pressing the PROG key to move to the READY mode.
2. Press the SETUP key in the standard display to move to the setup mode.
3. Press the down/up keys several times to select the setup items and press the ENT key.
4. Use the down/up keys to select the setup contents and press the ENT key.
5. Press the DISP key to move to the standard display.

◆ Setting Value

Setup Items	Setting Value
C76	1
C77	0
C78	0
C79	0
C80	0
C97	0

NOTE

- Parameters to be set vary depending on the Controller. Please refer to the manual of the Controller for more details.

4 Setup Items

Set communication settings of the Display with GP-Pro Ex or in off-line mode of the Display.

The setting of each parameter must be identical to that of External Device.

☞ "3 Example of Communication Setting" (page 9)

4.1 Setup Items in GP-Pro EX

■ Communication Settings

To display the setting screen, select [Device/PLC Settings] from [System setting window] in workspace.

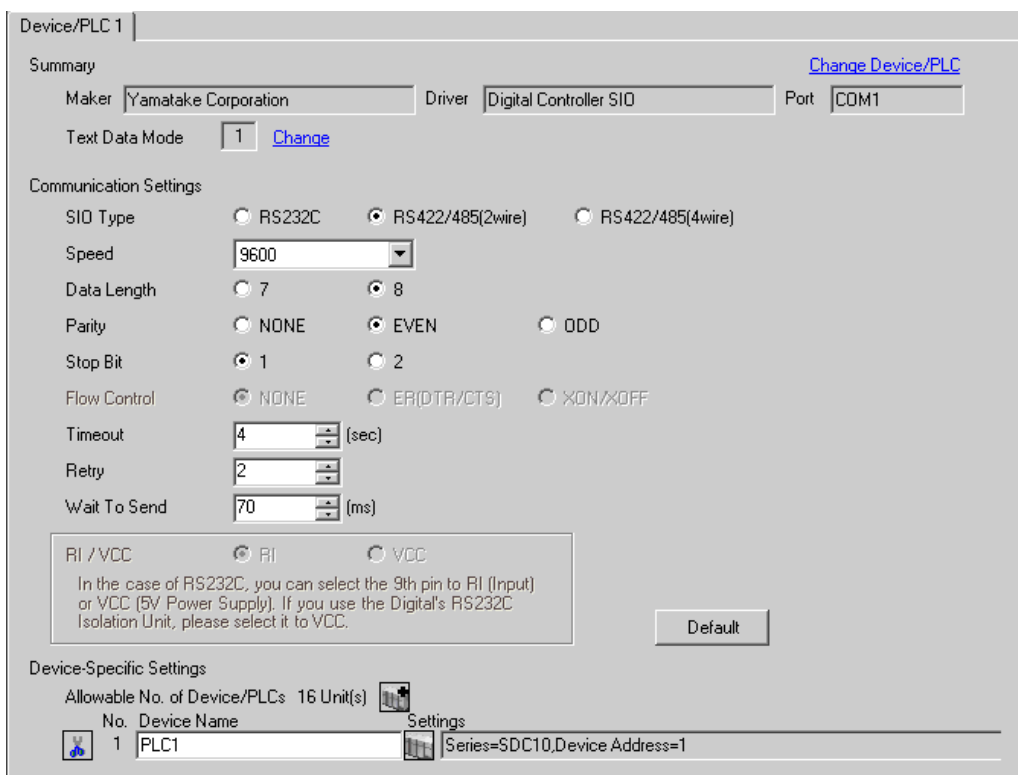

Device/PLC 1

Summary [Change Device/PLC](#)

Maker Driver Port

Text Data Mode [Change](#)

Communication Settings

SIO Type RS232C RS422/485(2wire) RS422/485(4wire)

Speed

Data Length 7 8

Parity NONE EVEN ODD

Stop Bit 1 2

Flow Control NONE ER(DTR/CTS) XON/XOFF

Timeout (sec)

Retry

Wait To Send (ms)

RI / VCC RI VCC

In the case of RS232C, you can select the 9th pin to RI (Input) or VCC (5V Power Supply). If you use the Digital's RS232C Isolation Unit, please select it to VCC.

Device-Specific Settings

Allowable No. of Device/PLCs 16 Unit(s)

No. Device Name Settings

Setup Items	Setup Description
SIO Type	Select the SIO type to communicate with the External Device.
Speed	Select speed between the External Device and the Display.
Data Length	Select data length.
Parity	Select how to check parity.
Stop Bit	Select stop bit length.
Flow Control	Display the communication control method to prevent overflow of transmission and reception data.
Timeout	Use an integer from 1 to 127 to enter the time (s) for which the Display waits for the response from the External Device.

continued to next page

Setup Items	Setup Description
Retry	In case of no response from the External Device, use an integer from 0 to 255 to enter how many times the Display retransmits the command.
Wait To Send	Use an integer from 0 to 255 to enter standby time (ms) for the Display from receiving packets to transmitting next commands.
RI/VCC	Switches RI/VCC of the 9th pin. It is necessary to change RI/5V by changeover switch of IPC when connect with IPC. Please refer to the manual of the IPC for more detail.

■ Device Setting

To display the setting screen, click  ([Setting]) of External Device you want to set from [Device-Specific Settings] of [Device/PLC Settings].

When you connect multiple External Device, click  from [Device-Specific Settings] of [Device/PLC Settings] to add another External Device.



Setup Items	Setup Description
Series	Displays a model of the External Device.
Device Address	Enter the address of the External Device, using 1 to 127.

4.2 Settings in Off-Line Mode

- NOTE** • Please refer to Maintenance/Troubleshooting for more information on how to enter off-line mode or about operation.

Cf: Maintenance/Troubleshooting "2.2 Offline Mode"

■ Communication Settings

To display the setting screen, touch [Device/PLC Settings] from [Peripheral Equipment Settings] in the off-line mode. Touch External Device you want to set from the displayed list.

Comm.	Device	Option		
Digital Controller SIO [COM1] Page 1/1				
SIO Type	RS422/485(4wire)			
Speed	9600			
Data Length	<input type="radio"/> 7 <input checked="" type="radio"/> 8 <input type="radio"/> NONE <input checked="" type="radio"/> EVEN <input type="radio"/> ODD			
Parity				
Stop Bit	<input checked="" type="radio"/> 1 <input type="radio"/> 2			
Flow Control	NONE			
Timeout(s)	3			
Retry	2			
Wait To Send(ms)	10			
Exit			Back	
2006/01/31 15:56:38				

Setup Items	Setup Description
SIO Type	Select the SIO type to communicate with the External Device. IMPORTANT To make the communication settings correctly, confirm the serial interface specifications of Display unit for [SIO Type]. We cannot guarantee the operation if a communication type that the serial interface does not support is specified. For details concerning the serial interface specifications, refer to the manual for Display unit.
Speed	Select speed between the External Device and the Display.
Data Length	Select data length.
Parity	Select how to check parity.
Stop Bit	Select stop bit length.
Flow Control	Display the communication control method to prevent overflow of transmission and reception data.
Timeout	Use an integer from 1 to 127 to enter the time (s) for which the Display waits for the response from the External Device.
Retry	In case of no response from the External Device, use an integer from 0 to 255 to enter how many times the Display retransmits the command.

Setup Items	Setup Description
Wait To Send	Use an integer from 0 to 255 to enter standby time (ms) for the Display from receiving packets to transmitting next commands.

■ Device Setting

To display the setting screen, touch [Device/PLC Settings] from [Peripheral Equipment Settings]. Touch the External Device you want to set from the displayed list, and touch [Device Settings].

Comm.	Device	Option		
Digital Controller SIO		[COM1]	Page 1/1	
Device/PLC Name	PLC1 ▼			
Series	SDC30/31			
Device Address	1 ▼ ▲			
	Exit		Back	2006/01/31 15:56:42

Setup Items	Setup Description
Device/PLC Name	Select the External Device to set. Device name is a title of the External Device set with GP-Pro EX. (Initial value [PLC1])
Series	Displays a model of the External Device.
Device Address	Enter the address of the External Device, using 1 to 127.

■ Option

To display the setting screen, touch [Device/PLC Settings] from [Peripheral Equipment Settings]. Touch the External Device you want to set from the displayed list, and touch [Option].

Comm.	Device	Option		
Digital Controller SIO		[COM1]	Page 1/1	
RI / VCC <input checked="" type="radio"/> RI <input type="radio"/> VCC In the case of RS232C, you can select the 9th pin to RI(Input) or VCC(5V Power Supply). If you use the Digital's RS232C Isolation Unit, please select it to VCC.				
	Exit		Back	2006/01/31 15:56:48

Setup Items	Setup Description
RI/VCC	Switches RI/VCC of the 9th pin. It is necessary to change RI/5V by changeover switch of IPC when connect with IPC. Please refer to the manual of the IPC for more detail.

5 Cable Diagram

The cable diagram shown below may be different from the cable diagram recommended by Yamatake Corporation. Please be assured there is no operational problem in applying the cable diagram shown in this manual.

- The FG pin of the main body of the External Device must be D-class grounded. Please refer to the manual of the External Device for more details.
- SG and FG are connected inside the Display. When connecting SG to the External Device, design the system not to form short-circuit loop.
- Check the terminal No. on the side of External Device in the manual of the External Device. It varies depending on the additional function.
- Connect the isolation unit, when communication is not stabilized under the influence of a noise etc.
- Recommended cable

Company Name		Model No.
Fujikura Densen	2 cores	IPEV-S-0.9mm ² x1P
	3 cores	ITEV-S-0.9mm ² x1T
Hitachi Densen	2 cores	KPEV-S-0.9mm ² x1P
	3 cores	KTEV-S-0.9mm ² x1T

Cable Diagram 1

Display (Connection Port)	Cable	Remarks
GP (COM1) LT (COM1) IPC*1 PC/AT	Your own cable	Cable length: 15m or less

*1 Only the COM port which can communicate by RS-232C can be used.

 ■ COM Port of IPC (page 6)

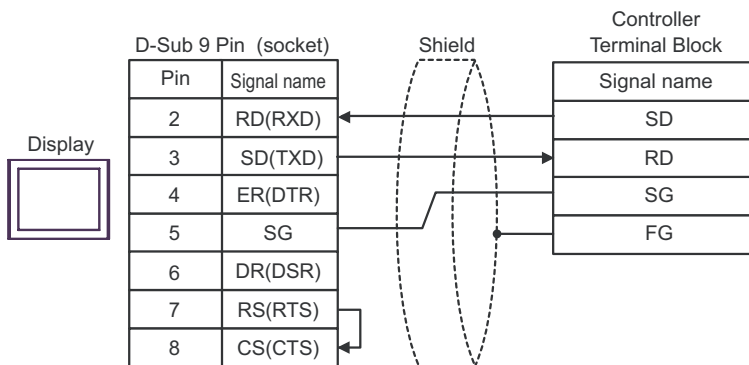

Cable Diagram 2

Display (Connection Port)	Cable		Remarks
GP* ¹ (COM1) AGP-3302B (COM2) LT (COM1)IPC* ²	A	COM port conversion adapter by Pro-face CA3-ADPCOM-01 + Terminal block conversion adapter by Pro-face CA3-ADPTRM-01 + Your own cable	Cable length: 500m or less
	B	Your own cable	
GP* ³ (COM2)	C	Online adapter by Pro-face CA4-ADPONL-01 + Terminal block conversion adapter by Pro-face CA3-ADPTRM-01 + Your own cable	
	D	Online adapter by Pro-face CA4-ADPONL-01 + Your own cable	

*1 All GP models except AGP-3302B

*2 Only the COM port which can communicate by RS-422/485 (4 wire) can be used.

 ■ COM Port of IPC (page 6)

*3 All GP models except GP-3200 series and AGP-3302B

A. When using the COM port conversion adapter (CA3-ADPCOM-01), the terminal block conversion adapter (CA3-ADPTRM-01) by Pro-face and your own cable

- 1:1 Connection

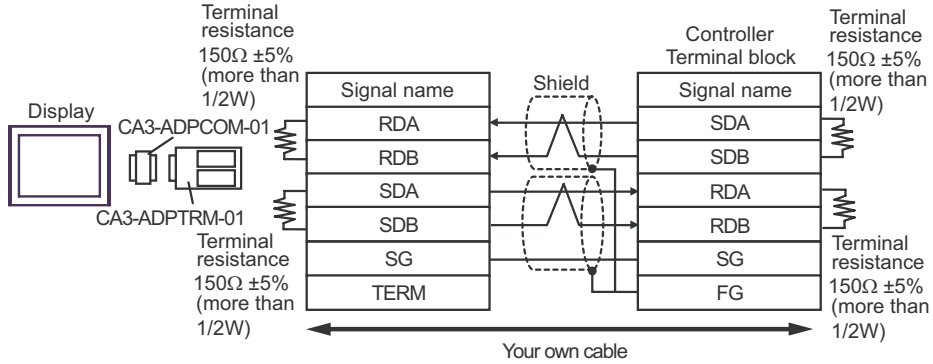

- 1:n Connection

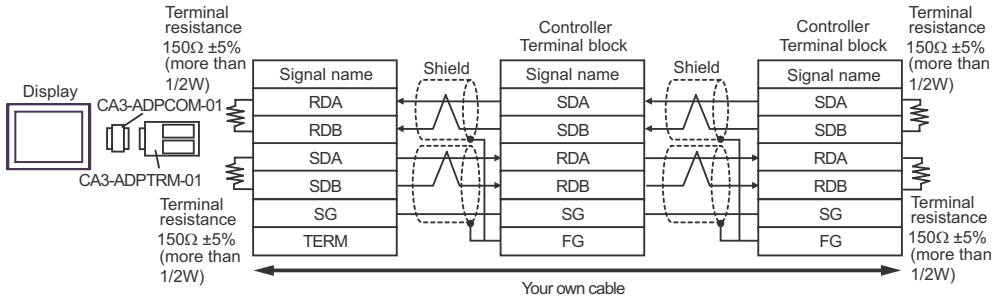

B. When self-made cable is used

- 1:1 Connection

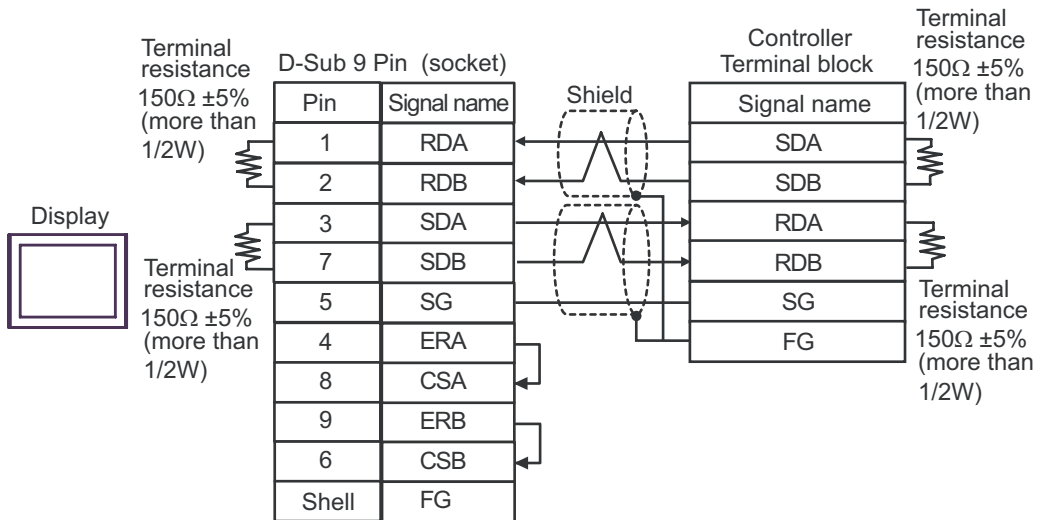

- 1:n Connection

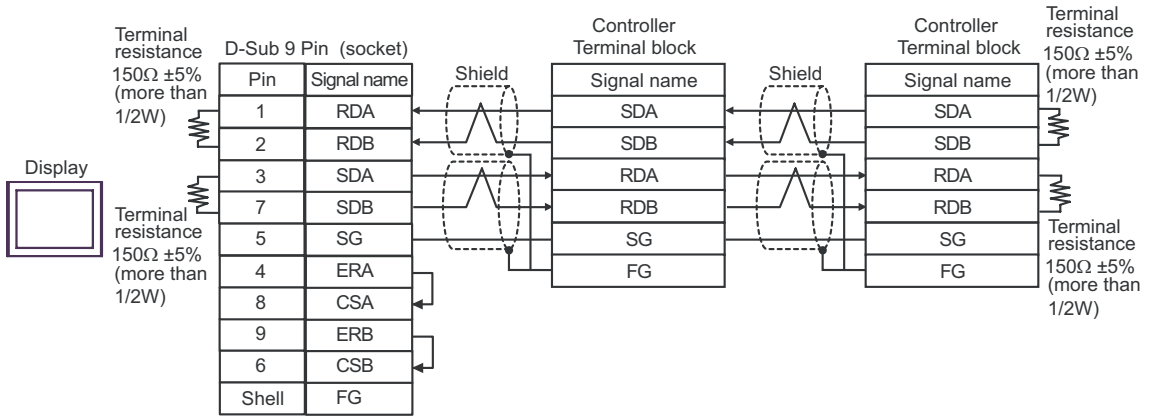

C. When using the online adapter (CA4-ADPONL-01), the terminal block conversion adapter (CA3-ADPTRM-01) by Pro-face and your own cable

- 1:1 Connection

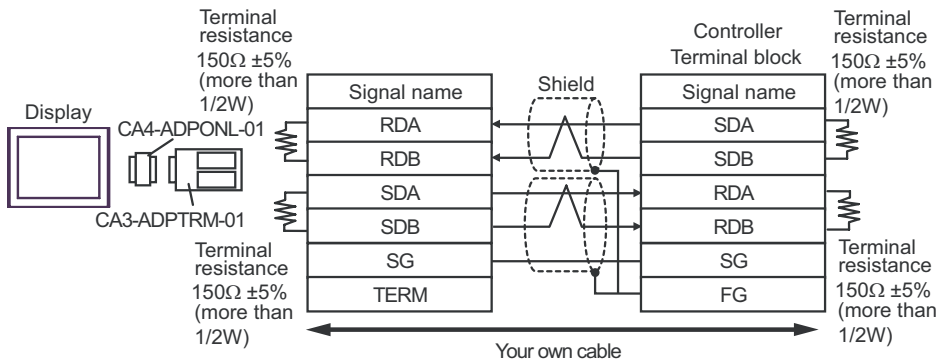

- 1:n connection

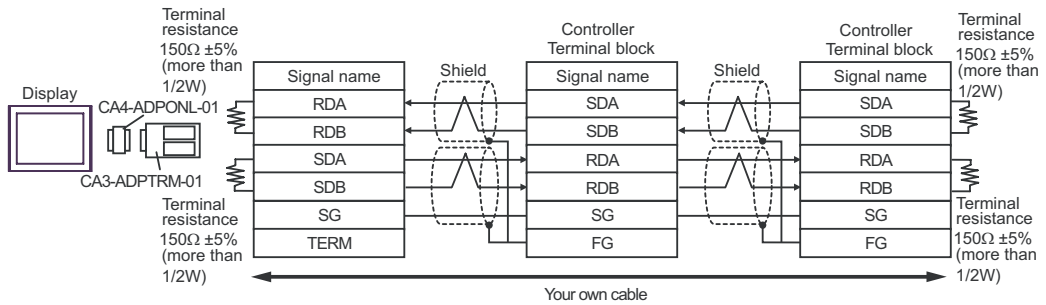

D. When using the online adapter (CA4-ADPONL-01) by Pro-face and your own cable

- 1:1 Connection

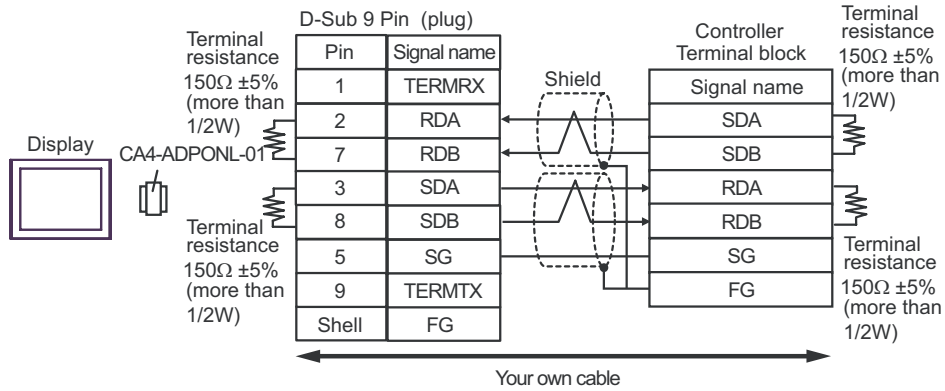

- 1:n Connection

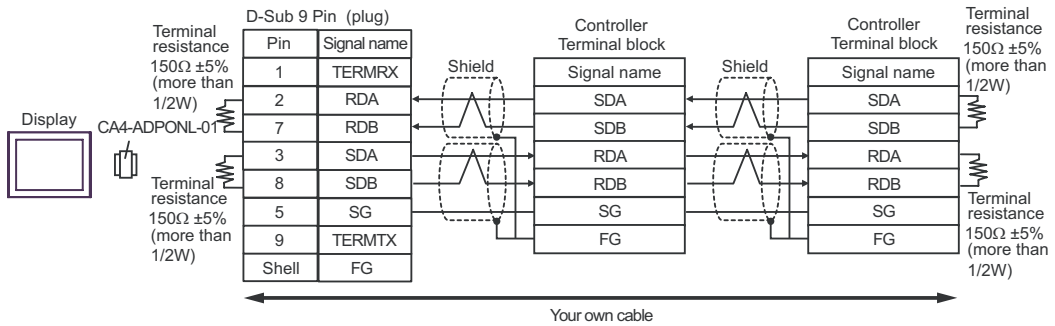

Cable Diagram 3

Display (Connection Port)	Cable		Remarks
GP* ¹ (COM1) AGP-3302B (COM2) LT (COM1)	A	COM port conversion adapter by Pro-face CA3-ADPCOM-01 + Terminal block conversion adapter by Pro-face CA3-ADPTRM-01 + Your own cable	Cable length: 500m or less
	B	Your own cable	
GP* ² (COM2)	C	Online adapter by Pro-face CA4-ADPONL-01 + Terminal block conversion adapter by Pro-face CA3-ADPTRM-01 + Your own cable	
	D	Online adapter by Pro-face CA4-ADPONL-01 + Your own cable	
IPC* ³	E	COM port conversion adapter by Pro-face CA3-ADPCOM-01 + Terminal block conversion adapter by Pro-face CA3-ADPTRM-01 + Your own cable	
	F	Your own cable	

*1 All GP models except AGP-3302B

*2 All GP models except GP-3200 series and AGP-3302B

*3 Only the COM port which can communicate by RS-422/485 (2 wire) can be used.

 ■ COM Port of IPC (page 6)

A. When using the COM port conversion adapter (CA3-ADPCOM-01), the terminal block conversion adapter (CA3-ADPTRM-01) by Pro-face and your own cable

- 1:1 Connection

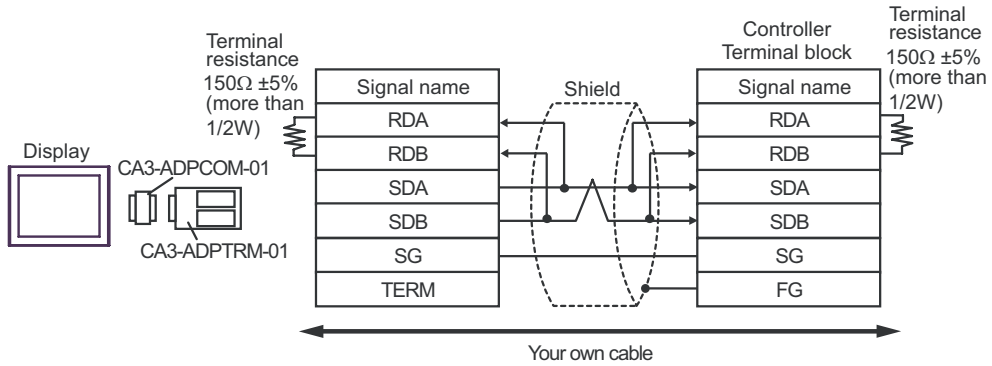

- 1:n Connection

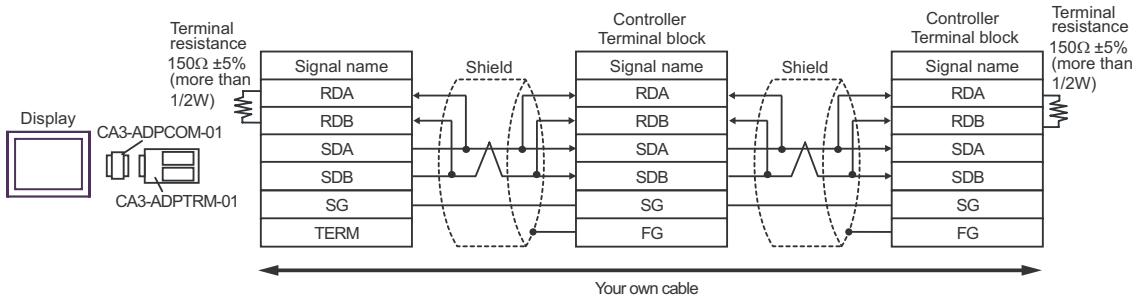

B. When self-made cable is used

- 1:1 Connection

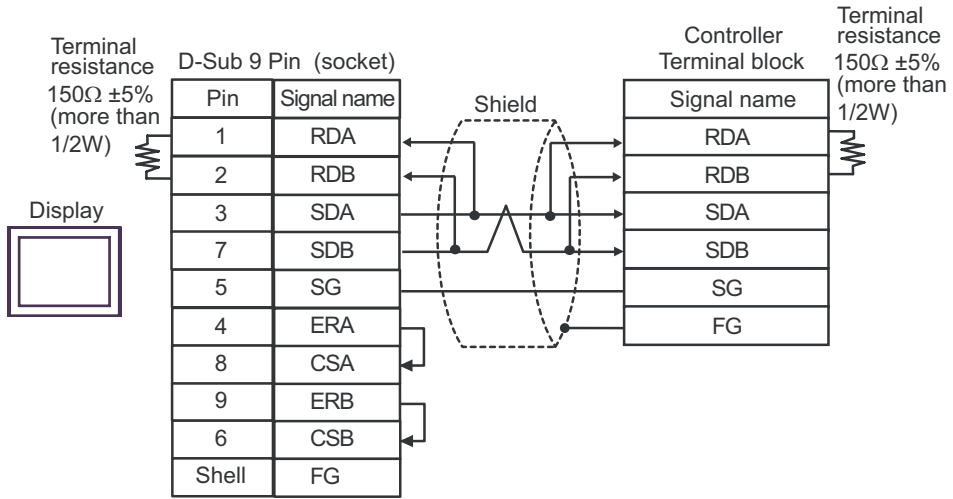

- 1:n Connection

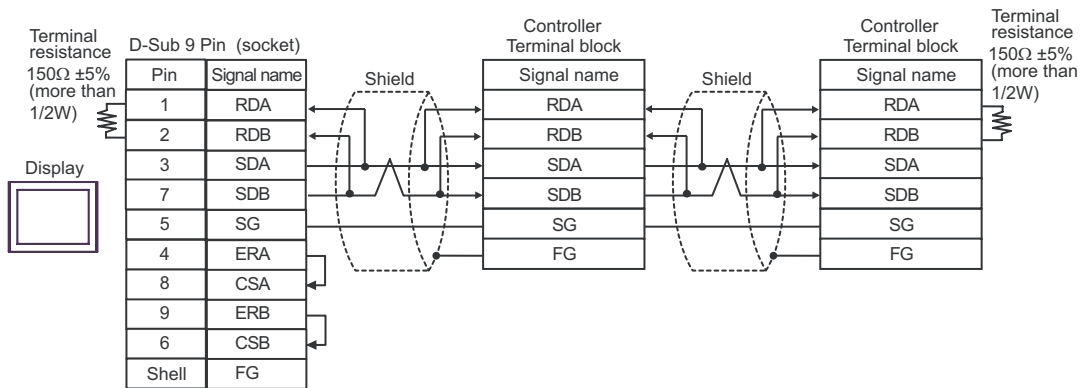

C. When using the online adapter (CA4-ADPONL-01), the terminal block conversion adapter (CA3-ADPTRM-01) by Pro-face and your own cable

- 1:1 Connection

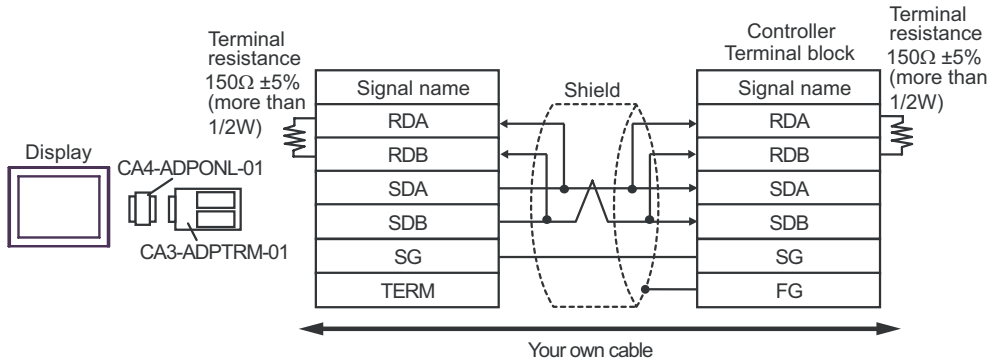

- 1:n Connection

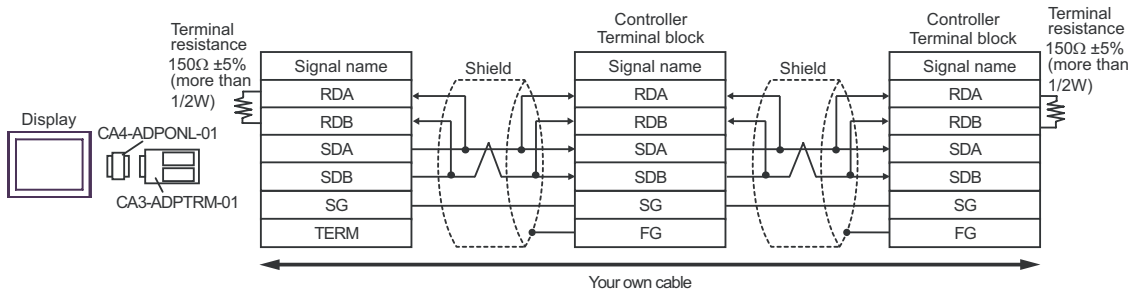

D. When using the online adapter (CA4-ADPONL-01) by Pro-face and your own cable

- 1:1 Connection

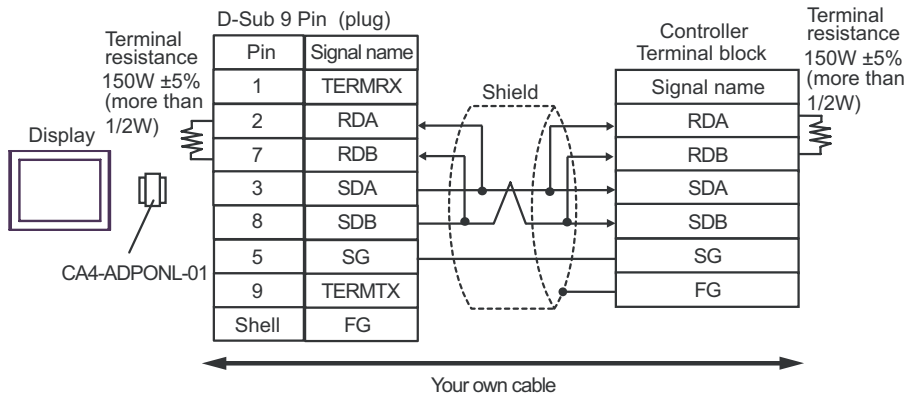

- 1:n Connection

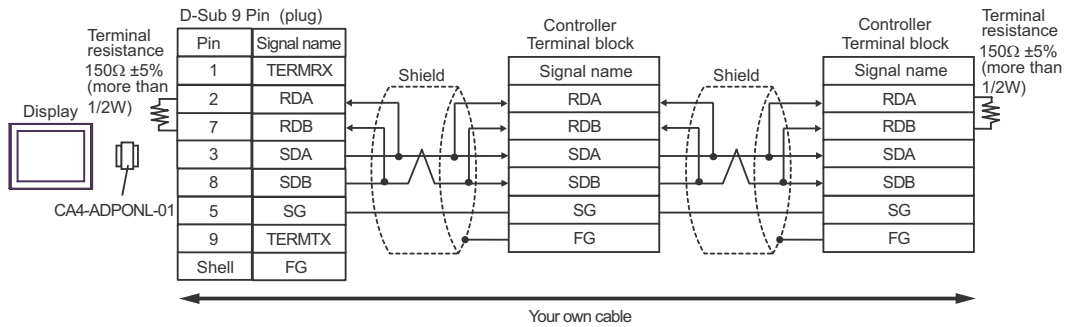

E. When using the COM port conversion adapter (CA3-ADPCOM-01), the terminal block conversion adapter (CA3-ADPTRM-01) by Pro-face and your own cable

- 1:1 Connection

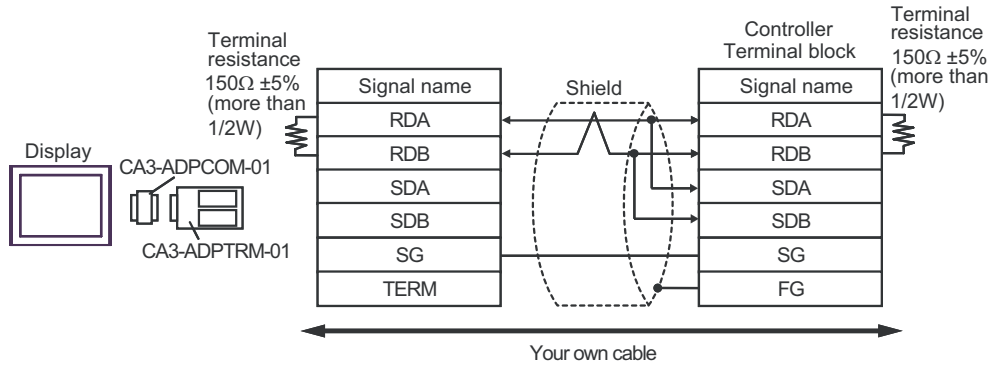

- 1:n Connection

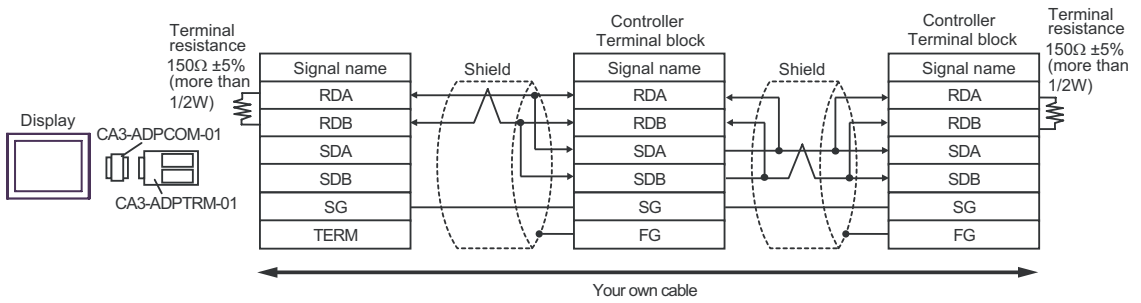

F. When self-made cable is used

- 1:1 Connection

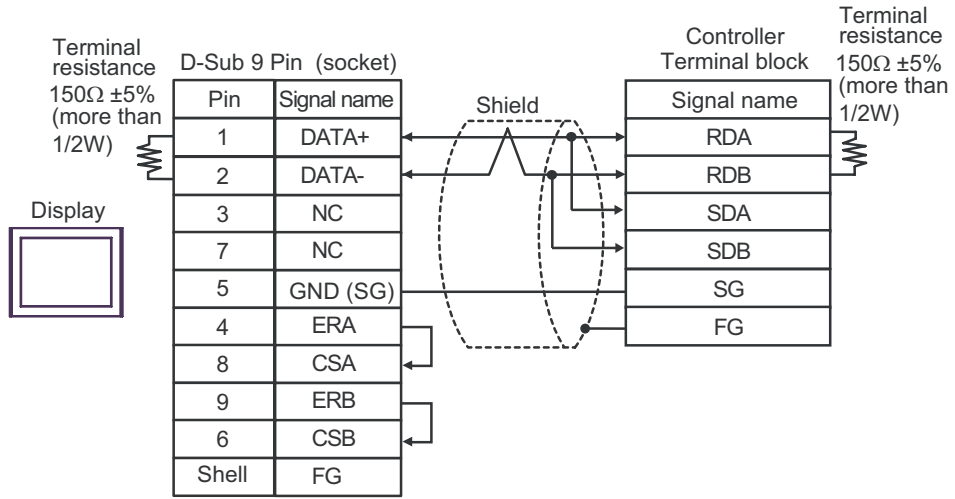

- 1:n Connection

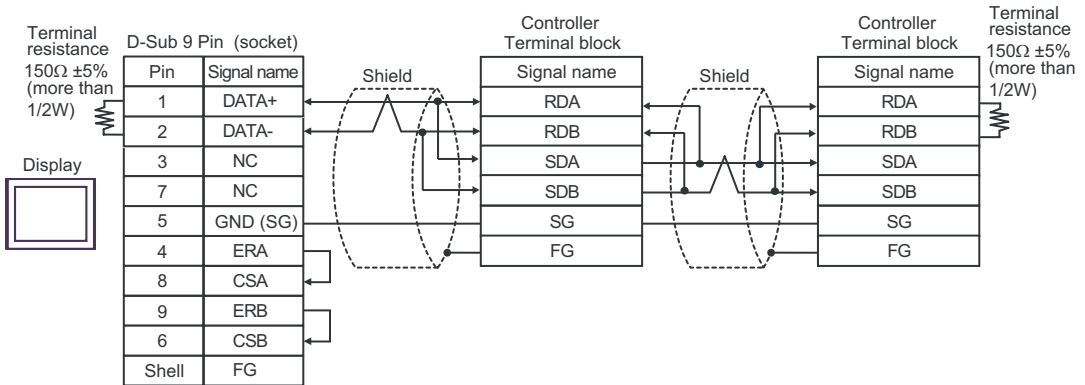

Cable Diagram 4

Display (Connection Port)	Cable		Remarks
GP*1 (COM1) AGP-3302B (COM2) LT (COM1)	A	COM port conversion adapter by Pro-face CA3-ADPCOM-01 + Terminal block conversion adapter by Pro-face CA3-ADPTRM-01 + Your own cable	Cable length: 500m or less
	B	Your own cable	
GP*2 (COM2)	C	Online adapter by Pro-face CA4-ADPONL-01 + Terminal block conversion adapter by Pro-face CA3-ADPTRM-01 + Your own cable	
	D	Online adapter by Pro-face CA4-ADPONL-01 + Your own cable	
IPC*3	E	COM port conversion adapter by Pro-face CA3-ADPCOM-01 + Terminal block conversion adapter by Pro-face CA3-ADPTRM-01 + Your own cable	
	F	Your own cable	

*1 All GP models except AGP-3302B

*2 All GP models except GP-3200 series and AGP-3302B

*3 Only the COM port which can communicate by RS-422/485 (2 wire) can be used.

 ■ COM Port of IPC (page 6)

A. When using the COM port conversion adapter (CA3-ADPCOM-01), the terminal block conversion adapter (CA3-ADPTRM-01) by Pro-face and your own cable

- 1:1 Connection

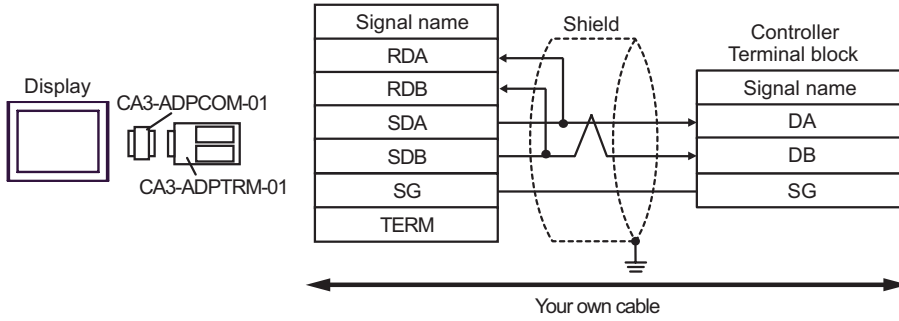

NOTE • Termination resistance is not necessary.

- 1:n Connection

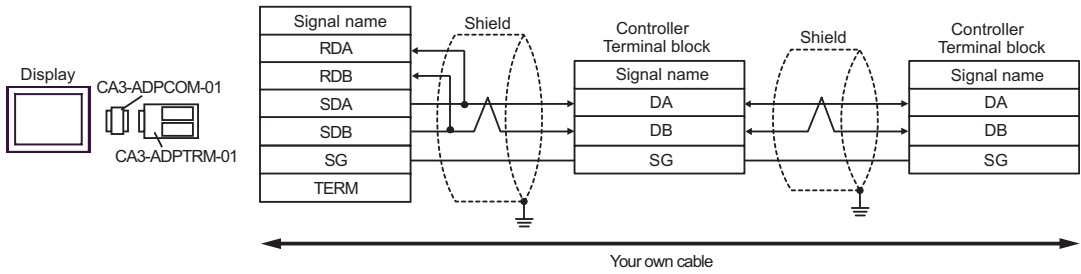

NOTE • Termination resistance is not necessary.

B. When self-made cable is used

- 1:1 Connection

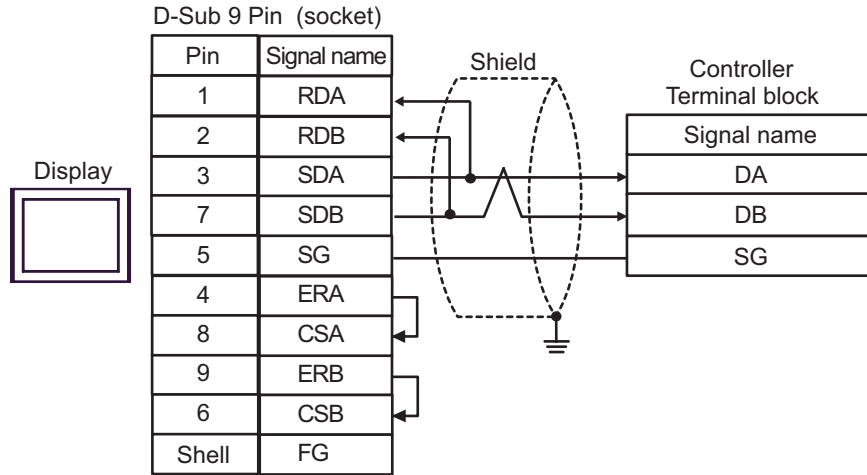

NOTE • Termination resistance is not necessary.

- 1:n Connection

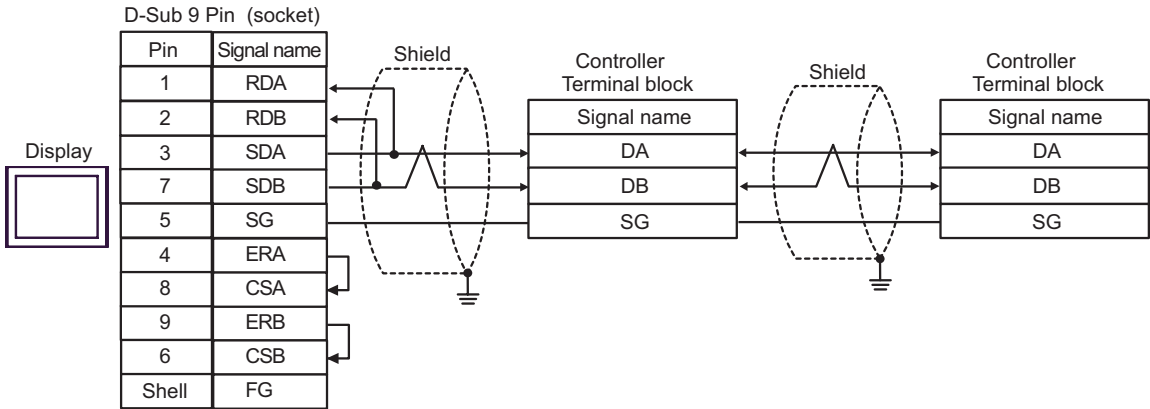

NOTE • Termination resistance is not necessary.

C. When using the online adapter (CA4-ADPONL-01), the terminal block conversion adapter (CA3-ADPTRM-01) by Pro-face and your own cable

- 1:1 Connection

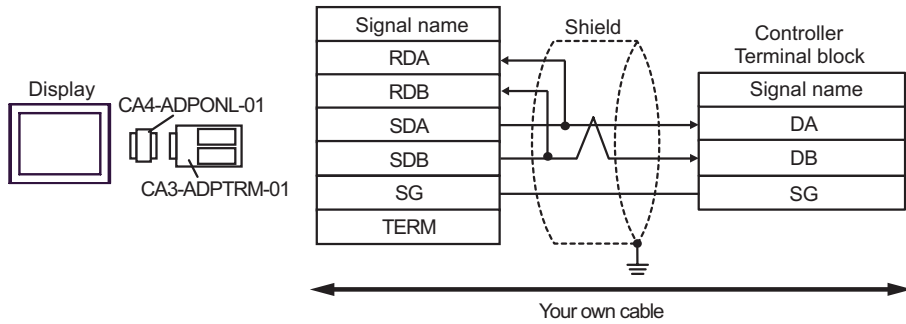

NOTE • Termination resistance is not necessary.

- 1:n Connection

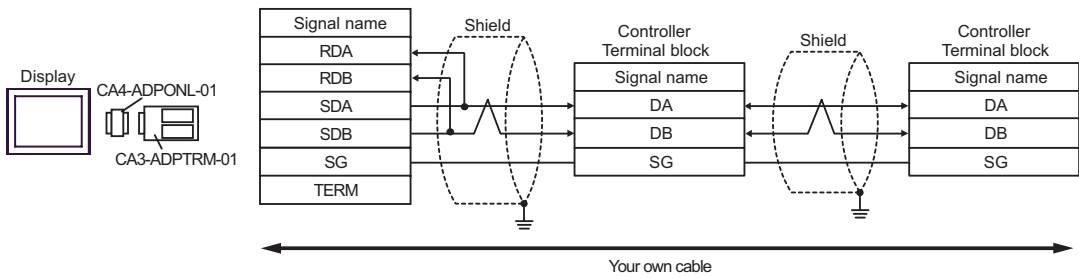

NOTE • Termination resistance is not necessary.

D. When using the online adapter (CA4-ADPONL-01) by Pro-face and your own cable

- 1:1 Connection

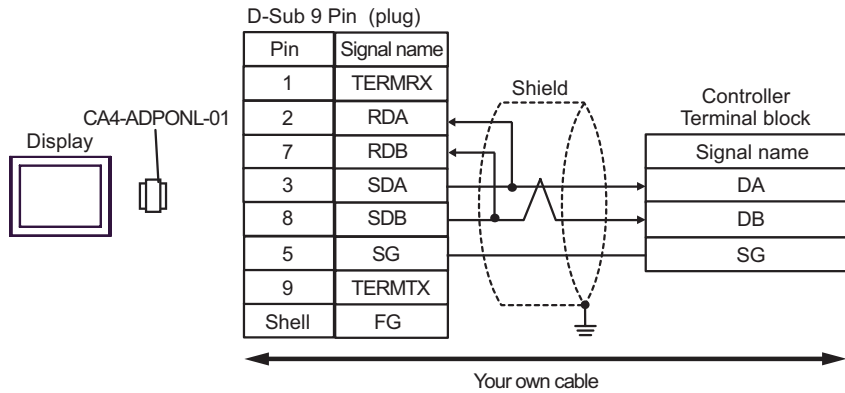

NOTE • Termination resistance is not necessary.

- 1:n Connection

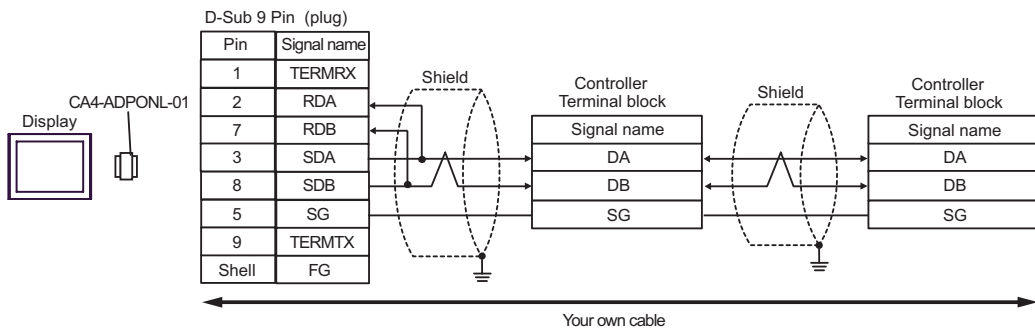

NOTE • Termination resistance is not necessary.

E. When using the COM port conversion adapter (CA3-ADPCOM-01), the terminal block conversion adapter (CA3-ADPTRM-01) by Pro-face and your own cable

- 1:1 Connection

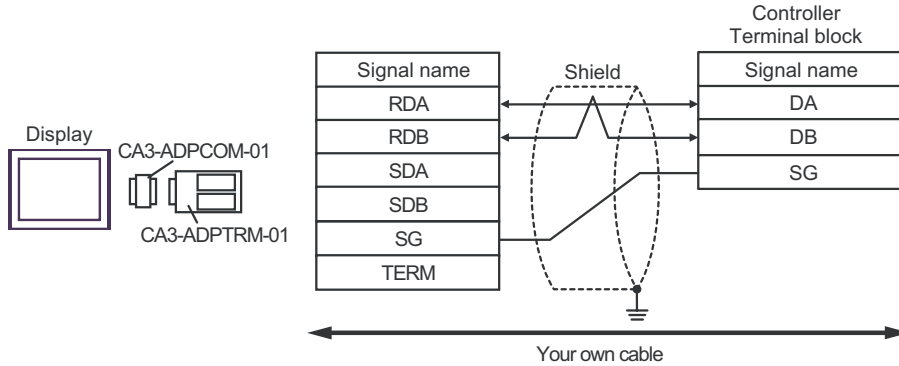

NOTE • Termination resistance is not necessary.

- 1:n Connection

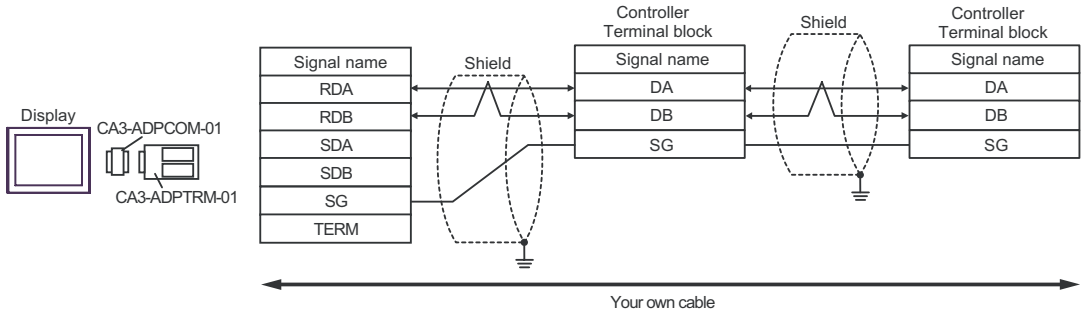

NOTE • Termination resistance is not necessary.

F. When self-made cable is used

- 1:1 Connection

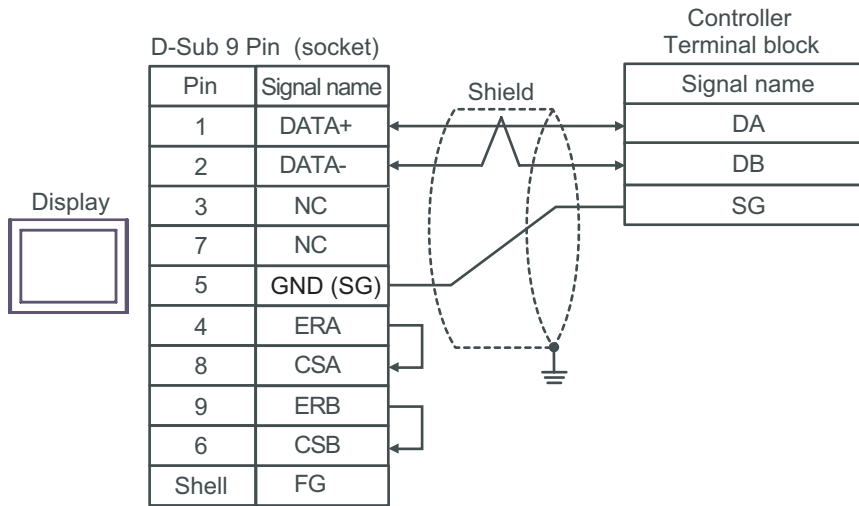

NOTE • Termination resistance is not necessary.

- 1:n Connection

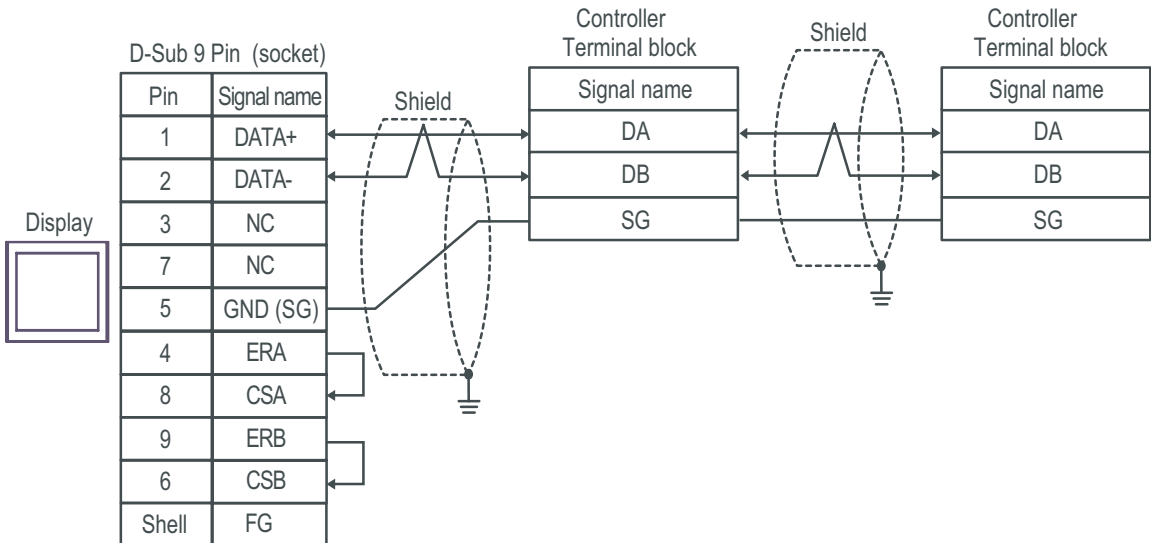

NOTE • Termination resistance is not necessary.

Cable Diagram 5

Display (Connection Port)	Cable		Remarks
GP*1 (COM1) AGP-3302B (COM2) LT (COM1)	A	COM port conversion adapter by Pro-face CA3-ADPCOM-01 + Terminal block conversion adapter by Pro-face CA3-ADPTRM-01 + Your own cable	Cable length: 500m or less
	B	Your own cable	
GP*2 (COM2)	C	Online adapter by Pro-face CA4-ADPONL-01 + Terminal block conversion adapter by Pro-face CA3-ADPTRM-01 + Your own cable	
	D	Online adapter by Pro-face CA4-ADPONL-01 + Your own cable	
IPC*3	E	COM port conversion adapter by Pro-face CA3-ADPCOM-01 + Terminal block conversion adapter by Pro-face CA3-ADPTRM-01 + Your own cable	
	F	Your own cable	

*1 All GP models except AGP-3302B

*2 All GP models except GP-3200 series and AGP-3302B

*3 Only the COM port which can communicate by RS-422/485 (2 wire) can be used.

 ■ COM Port of IPC (page 6)

A. When using the COM port conversion adapter (CA3-ADPCOM-01), the terminal block conversion adapter (CA3-ADPTRM-01) by Pro-face and your own cable

- 1:1 Connection

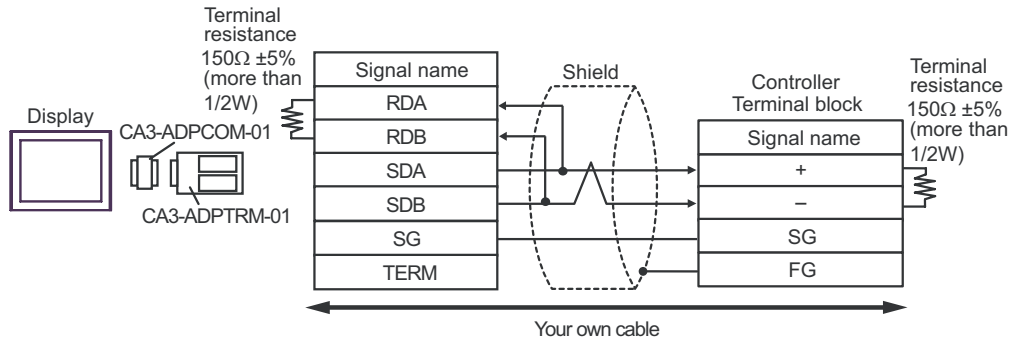

- 1:n Connection

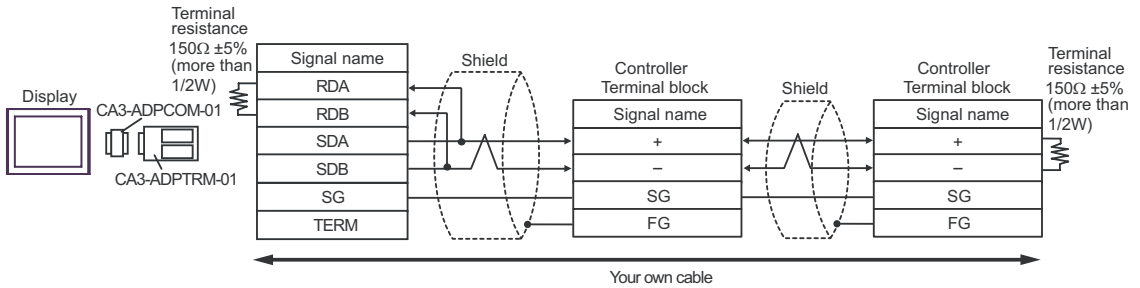

B. When self-made cable is used

- 1:1 Connection

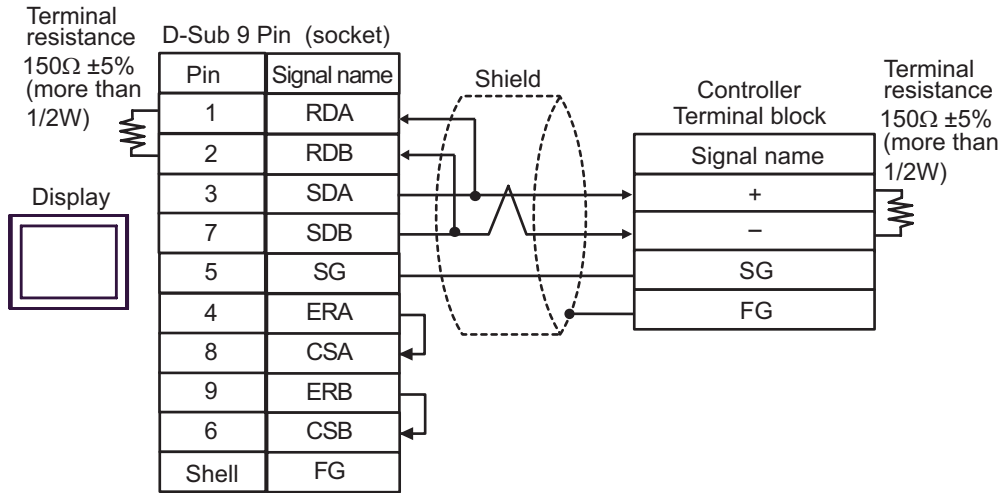

- 1:n Connection

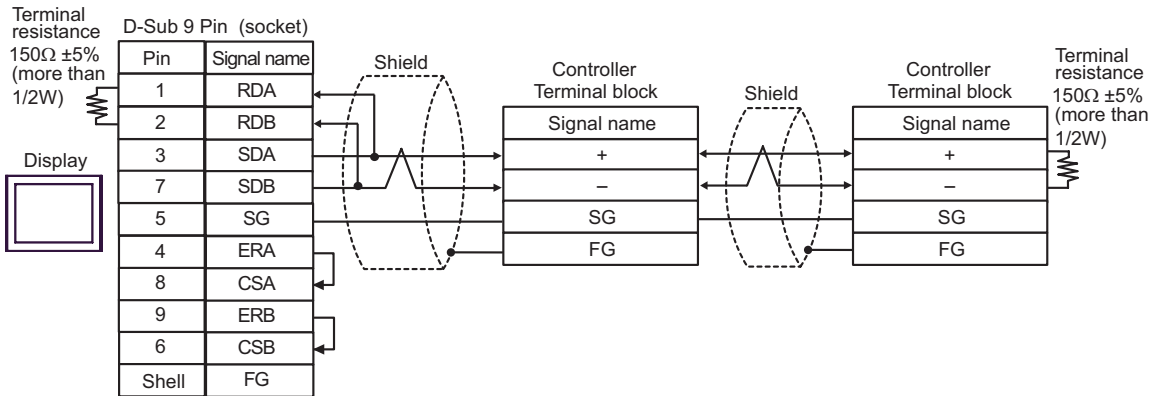

C. When using the online adapter (CA4-ADPONL-01), the terminal block conversion adapter (CA3-ADPTRM-01) by Pro-face and your own cable

- 1:1 Connection

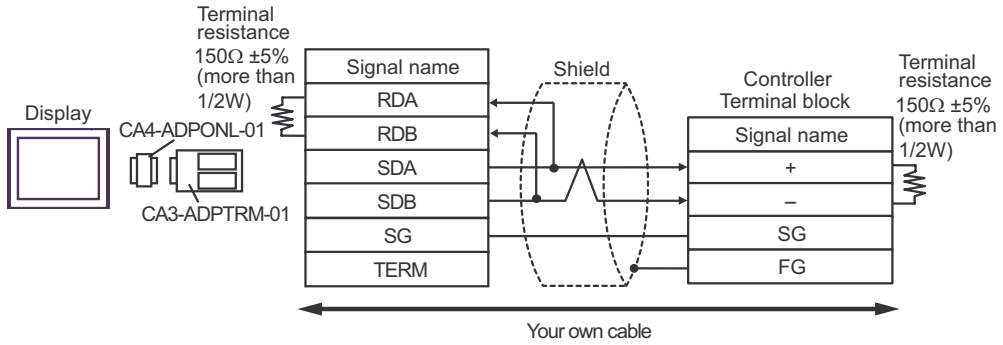

- 1:n Connection

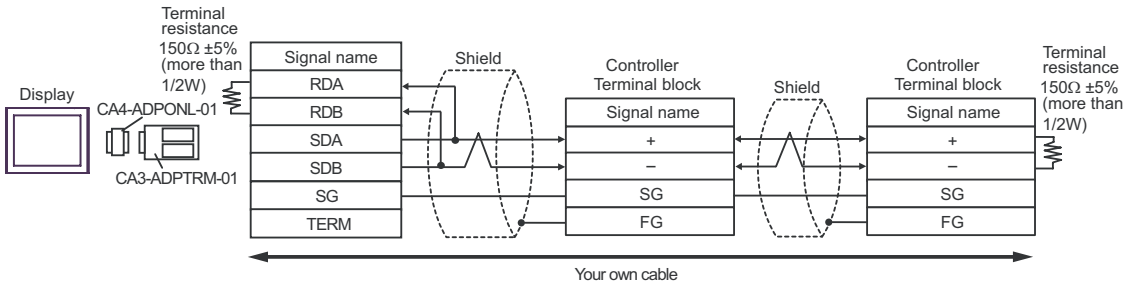

D. When using the online adapter (CA4-ADPONL-01) by Pro-face and your own cable

- 1:1 Connection

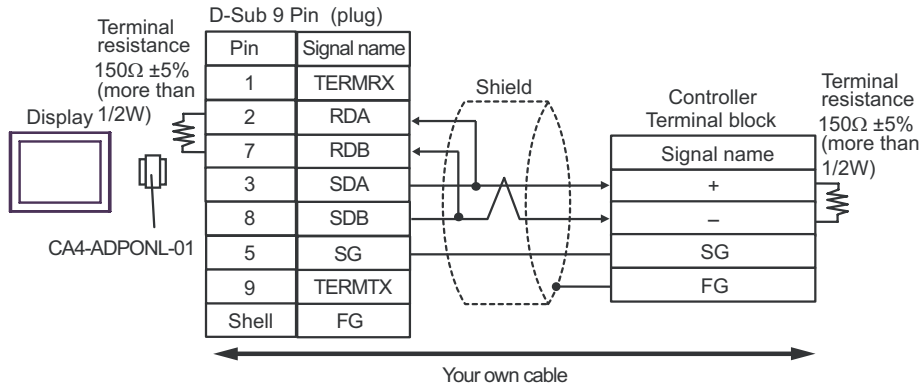

- 1:n Connection

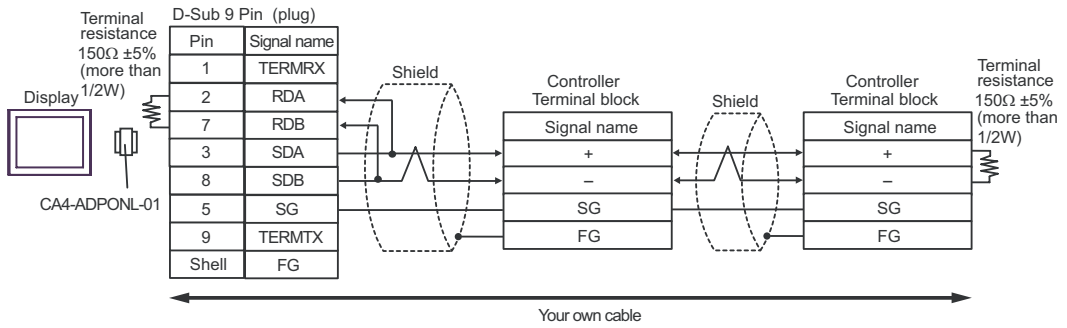

E. When using the COM port conversion adapter (CA3-ADPCOM-01), the terminal block conversion adapter (CA3-ADPTRM-01) by Pro-face and your own cable

- 1:1 Connection

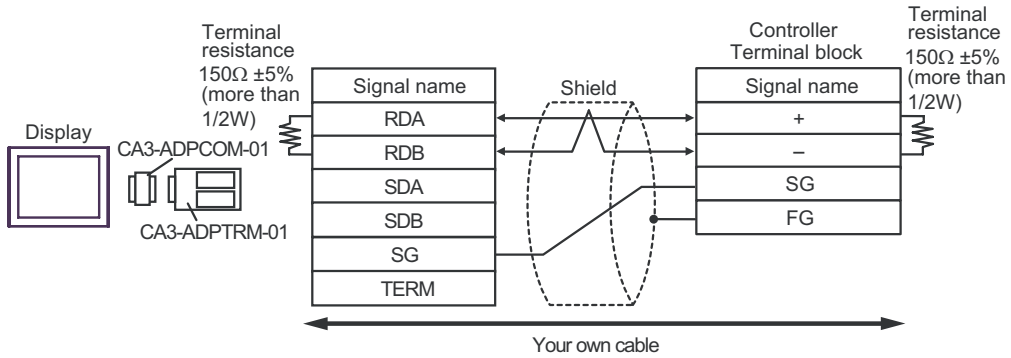

- 1:n Connection

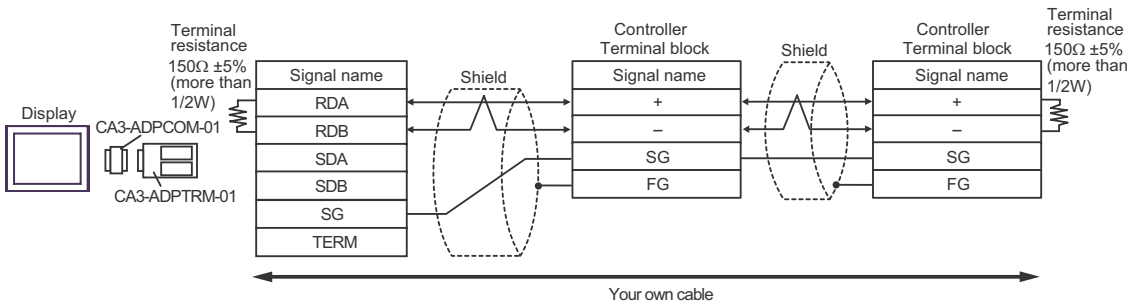

F. When self-made cable is used

- 1:1 Connection

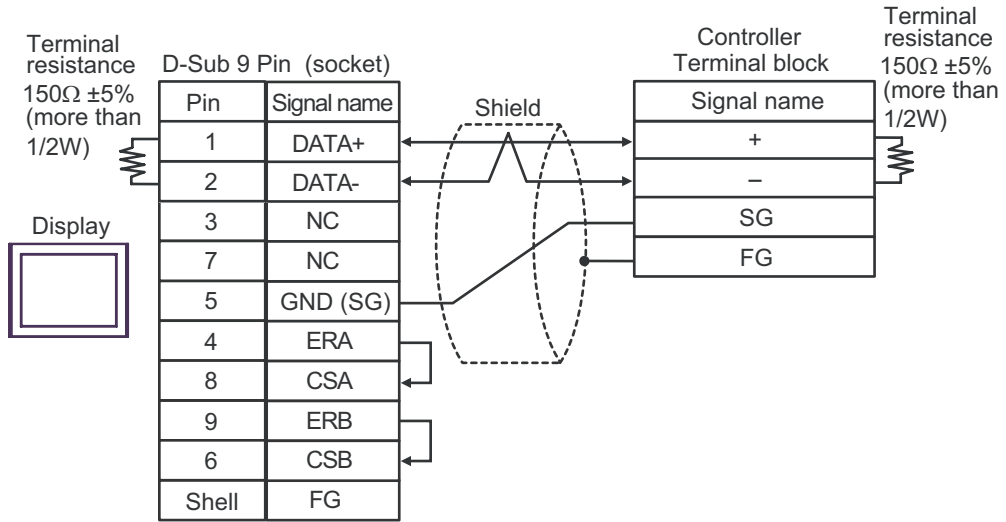

- 1:n Connection

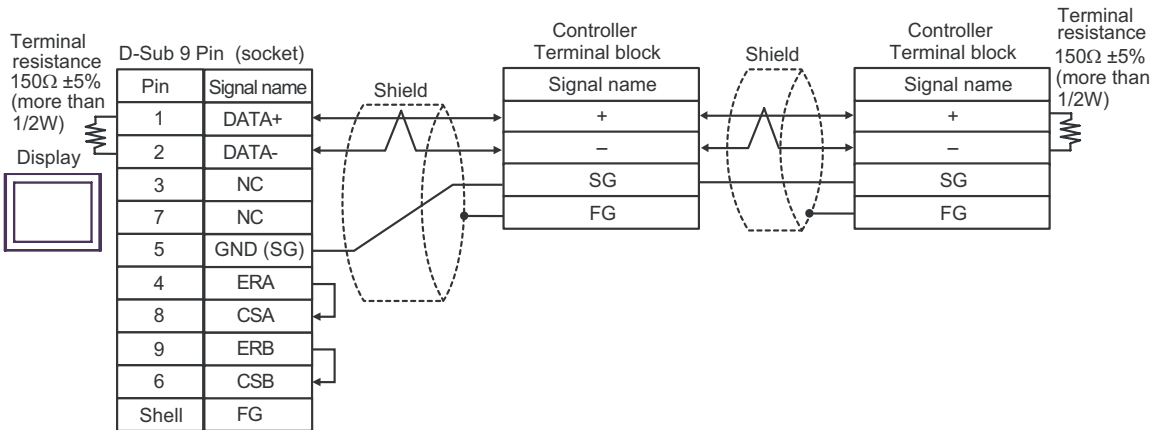

Cable Diagram 6

Display (Connection Port)	Cable		Remarks
GP*1 (COM1) AGP-3302B (COM2) LT (COM1)	A	COM port conversion adapter by Pro-face CA3-ADPCOM-01 + Terminal block conversion adapter by Pro-face CA3-ADPTRM-01 + Your own cable	Cable length: 500m or less
	B	Your own cable	
GP*2 (COM2)	C	Online adapter by Pro-face CA4-ADPONL-01 + Terminal block conversion adapter by Pro-face CA3-ADPTRM-01 + Your own cable	
	D	Online adapter by Pro-face CA4-ADPONL-01 + Your own cable	
IPC*3	E	COM port conversion adapter by Pro-face CA3-ADPCOM-01 + Terminal block conversion adapter by Pro-face CA3-ADPTRM-01 + Your own cable	
	F	Your own cable	

*1 All GP models except AGP-3302B

*2 All GP models except GP-3200 series and AGP-3302B

*3 Only the COM port which can communicate by RS-422/485 (2 wire) can be used.

 ■ COM Port of IPC (page 6)

A. When using the COM port conversion adapter (CA3-ADPCOM-01), the terminal block conversion adapter (CA3-ADPTRM-01) by Pro-face and your own cable

- 1:1 Connection

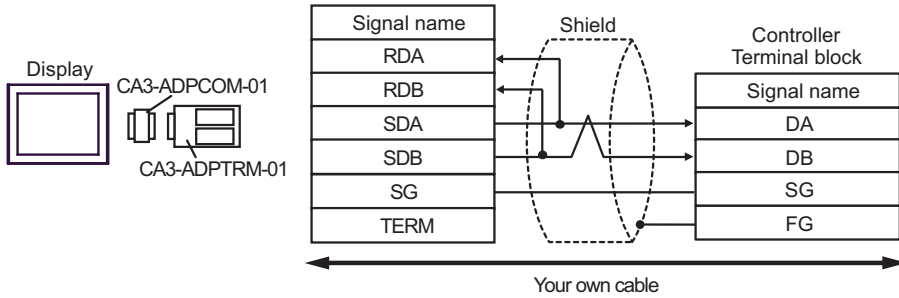

NOTE • Termination resistance is not necessary.

- 1:n Connection

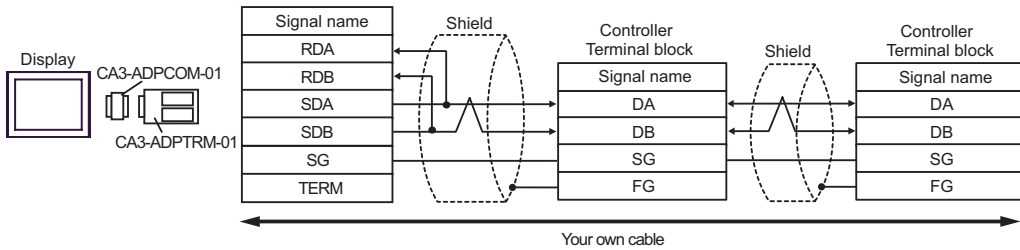

NOTE • Termination resistance is not necessary.

B. When self-made cable is used

- 1:1 Connection

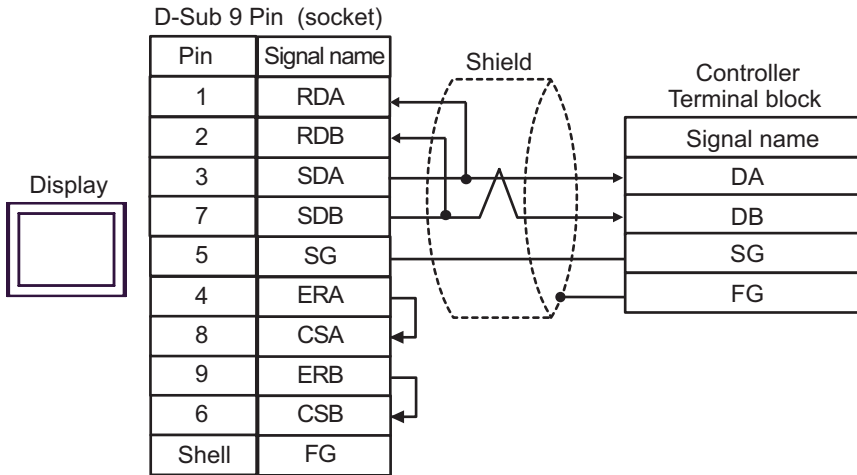

NOTE • Termination resistance is not necessary.

- 1:n Connection

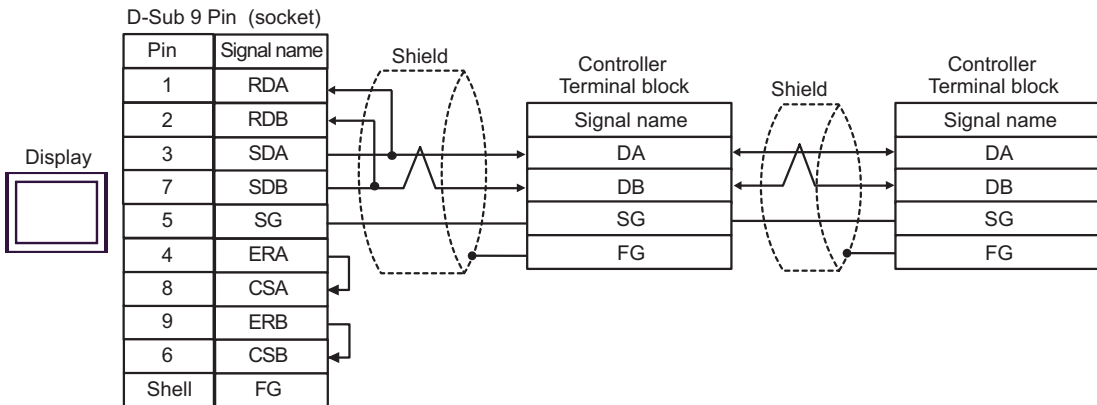

NOTE • Termination resistance is not necessary.

C. When using the online adapter (CA4-ADPONL-01), the terminal block conversion adapter (CA3-ADPTRM-01) by Pro-face and your own cable

- 1:1 Connection

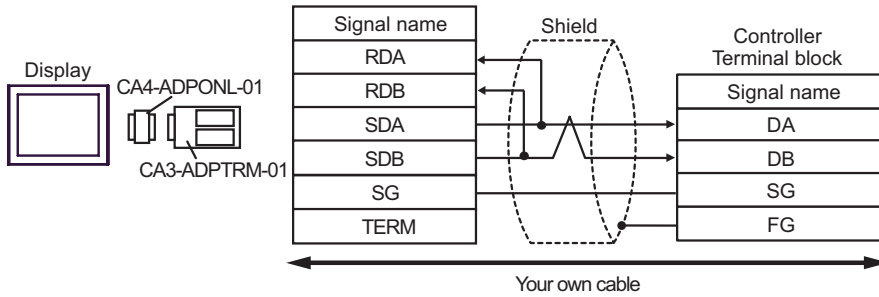

NOTE • Termination resistance is not necessary.

- 1:n Connection

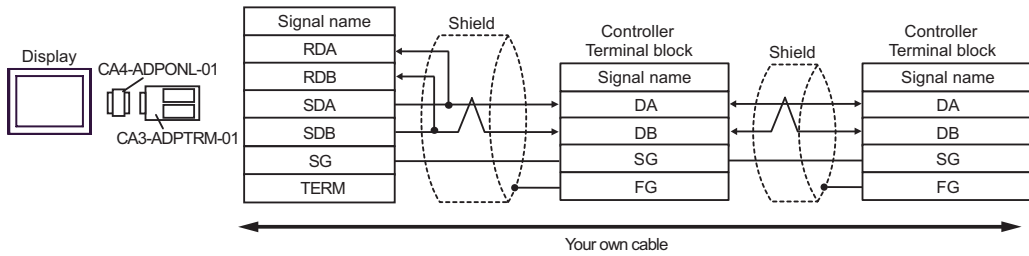

NOTE • Termination resistance is not necessary.

D. When using the online adapter (CA4-ADPONL-01) by Pro-face and your own cable

- 1:1 Connection

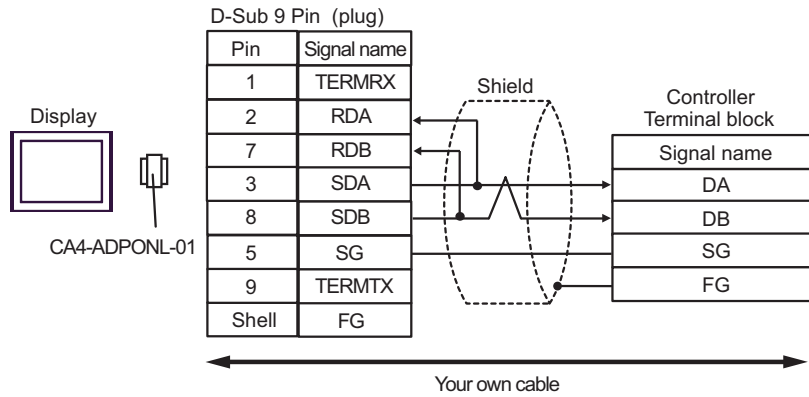

NOTE • Termination resistance is not necessary.

- 1:n Connection

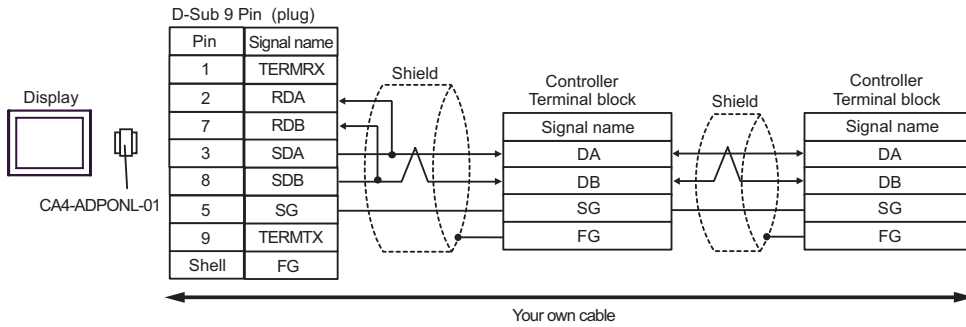

NOTE • Termination resistance is not necessary.

E. When using the COM port conversion adapter (CA3-ADPCOM-01), the terminal block conversion adapter (CA3-ADPTRM-01) by Pro-face and your own cable

- 1:1 Connection

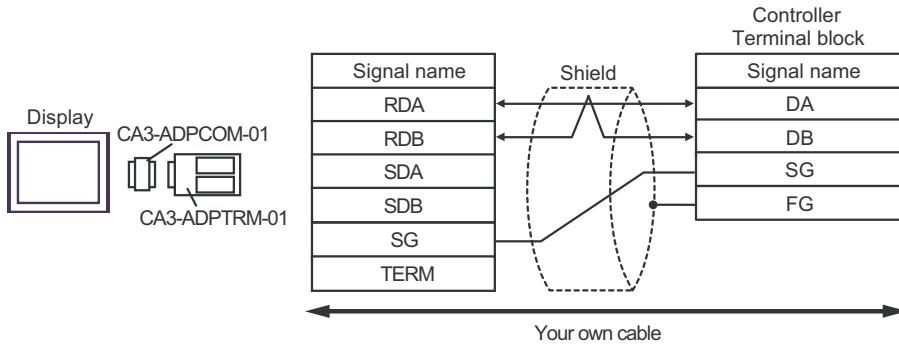

NOTE • Termination resistance is not necessary.

- 1:n Connection

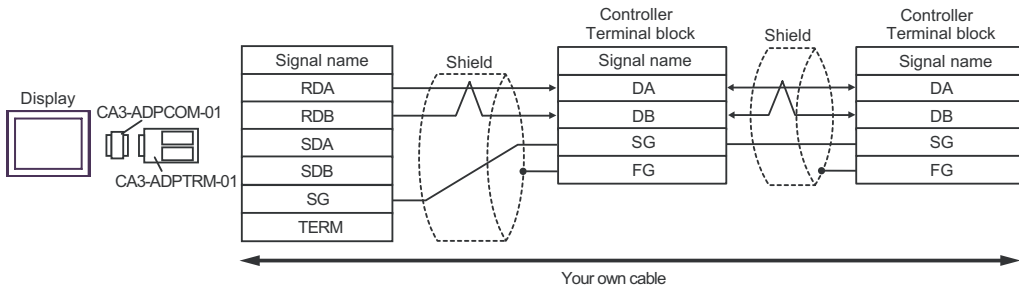

NOTE • Termination resistance is not necessary.

F. When self-made cable is used

- 1:1 Connection

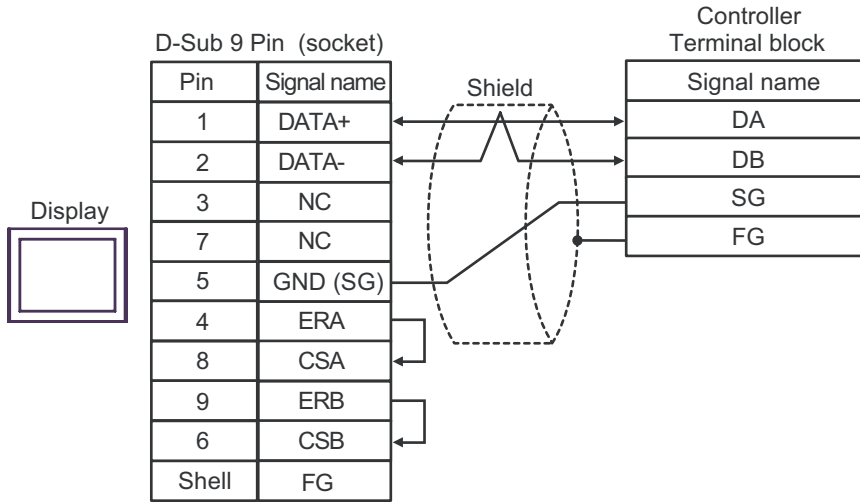

NOTE • Termination resistance is not necessary.

- 1:n Connection

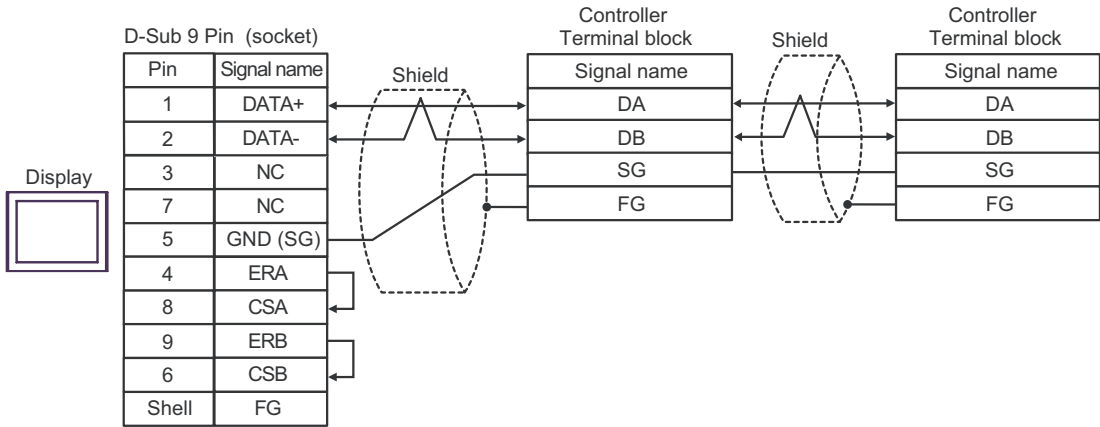

NOTE • Termination resistance is not necessary.

6 Supported Device

Range of supported device address is shown in the table below. Please note that the actually supported range of the devices varies depending on the External Device to be used. Please check the actual range in the manual of your External Device.

Enter the External Device address in the dialog below.

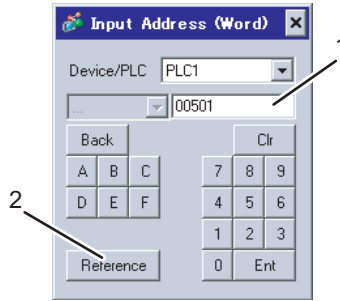

1. Address
2. Reference

Enter the address.

Available parameter list is displayed.

Click the parameter to use and press "Select", then the address is entered.

6.1 SDC10

 This address can be specified as system data area.

Device	Bit Address	Word Address	32 bit	Remarks
Data	00501.0-04504.F	00501-04504	[L/H]	*1

*1 When you write the bit address, the Display reads the word address corresponding to that of the External Device first. Then, it changes the target bit address among the word data once read and returns the word data to the External Device. Note that the correct data may not be written if you change the word address value in the ladder program while the Display reads the data of the External Device and returns it to the External Device.

IMPORTA • To set [Enable System Data Area] in the system area setting of GP-Pro EX may cause malfunction. Do not set [Enable System Data Area].

NOTE • You can set only reading area size for the system data area available to use in the Controller. Please refer to the GP-Pro EX Reference Manual for reading area size.

Cf: GP-Pro EX Reference Manual "Appendix 1.4 LS Area (only for direct access method)"

- Please refer to the precautions on manual notation for icons in the table.

☞ "Manual Symbols and Terminology"

- Even if you use the nonexistent address, read error may not be displayed. In this case, "0" is retained for the read data. Note that the writing error is displayed.

6.2 SDC15/SDC25/SDC26/SDC35/SDC36

 This address can be specified as system data area.

Device	Bit Address	Word Address	32 bit	Remarks
Data	00273.0-31243.F	00273-31243		*1

*1 When you write the bit address, the Display reads the word address corresponding to that of the External Device first. Then, it changes the target bit address among the word data once read and returns the word data to the External Device. Note that the correct data may not be written if you change the word address value in the ladder program while the Display reads the data of the External Device and returns it to the External Device.

IMPORTA • To set [Enable System Data Area] in the system area setting of GP-Pro EX may cause malfunction. Do not set [Enable System Data Area].

NOTE • You can set only reading area size for the system data area available to use in the Controller. Please refer to the GP-Pro EX Reference Manual for reading area size.

Cf: GP-Pro EX Reference Manual "Appendix 1.4 LS Area (only for direct access method)"



- Please refer to the precautions on manual notation for icons in the table.

 "Manual Symbols and Terminology"

- Even if you use the nonexistent address, read error may not be displayed. In this case, "0" is retained for the read data. Note that the writing error is displayed.
-

6.3 SDC20/SDC21

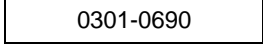
 This address can be specified as system data area.

Device	Bit Address	Word Address	32 bit	Remarks
Data	0301.0-0690.F	 0301-0690		*1

*1 When you write the bit address, the Display reads the word address corresponding to that of the External Device first. Then, it changes the target bit address among the word data once read and returns the word data to the External Device. Note that the correct data may not be written if you change the word address value in the ladder program while the Display reads the data of the External Device and returns it to the External Device.

IMPORTANT • To set [Enable System Data Area] in the system area setting of GP-Pro EX may cause malfunction. Do not set [Enable System Data Area].

NOTE • You can set only reading area size for the system data area available to use in the Controller. Please refer to the GP-Pro EX Reference Manual for reading area size.

Cf: GP-Pro EX Reference Manual "Appendix 1.4 LS Area (only for direct access method)"

- Please refer to the precautions on manual notation for icons in the table.
 -  "Manual Symbols and Terminology"
 - Even if you use the nonexistent address, read error may not be displayed. In this case, "0" is retained for the read data. Note that the writing error is displayed.
-

6.4 SDC30/SDC31

 This address can be specified as system data area.

Device	Bit Address	Word Address	32 bit	Remarks
Data	00501.0-06049.F	00501-06049		*1

*1 When you write the bit address, the Display reads the word address corresponding to that of the External Device first. Then, it changes the target bit address among the word data once read and returns the word data to the External Device. Note that the correct data may not be written if you change the word address value in the ladder program while the Display reads the data of the External Device and returns it to the External Device.

IMPORTANT

- To set [Enable System Data Area] in the system area setting of GP-Pro EX may cause malfunction. Do not set [Enable System Data Area].

NOTE

- You can set only reading area size for the system data area available to use in the Controller. Please refer to the GP-Pro EX Reference Manual for reading area size.

Cf: GP-Pro EX Reference Manual "Appendix 1.4 LS Area (only for direct access method)"

- Please refer to the precautions on manual notation for icons in the table.
 -  "Manual Symbols and Terminology"
- Even if you use the nonexistent address, read error may not be displayed. In this case, "0" is retained for the read data. Note that the writing error is displayed.

6.5 SDC40A

 This address can be specified as system data area.

Device	Bit Address	Word Address	32 bit	Remarks
Data	00501.0-06100.F	00501-06100		*1

*1 When you write the bit address, the Display reads the word address corresponding to that of the External Device first. Then, it changes the target bit address among the word data once read and returns the word data to the External Device. Note that the correct data may not be written if you change the word address value in the ladder program while the Display reads the data of the External Device and returns it to the External Device.

IMPORTANT • To set [Enable System Data Area] in the system area setting of GP-Pro EX may cause malfunction. Do not set [Enable System Data Area].

NOTE • You can set only reading area size for the system data area available to use in the Controller. Please refer to the GP-Pro EX Reference Manual for reading area size.

Cf: GP-Pro EX Reference Manual "Appendix 1.4 LS Area (only for direct access method)"

- Please refer to the precautions on manual notation for icons in the table.
 -  "Manual Symbols and Terminology"
 - Even if you use the nonexistent address, read error may not be displayed. In this case, "0" is retained for the read data. Note that the writing error is displayed.
-

6.6 SDC40B

 This address can be specified as system data area.

Device	Bit Address	Word Address	32 bit	Remarks
Data	00501.0-08902.F	00501-08902		*1

*1 When you write the bit address, the Display reads the word address corresponding to that of the External Device first. Then, it changes the target bit address among the word data once read and returns the word data to the External Device. Note that the correct data may not be written if you change the word address value in the ladder program while the Display reads the data of the External Device and returns it to the External Device.

IMPORTANT • To set [Enable System Data Area] in the system area setting of GP-Pro EX may cause malfunction. Do not set [Enable System Data Area].

NOTE • You can set only reading area size for the system data area available to use in the Controller. Please refer to the GP-Pro EX Reference Manual for reading area size.

Cf: GP-Pro EX Reference Manual "Appendix 1.4 LS Area (only for direct access method)"

- Please refer to the precautions on manual notation for icons in the table.
 -  "Manual Symbols and Terminology"
 - Even if you use the nonexistent address, read error may not be displayed. In this case, "0" is retained for the read data. Note that the writing error is displayed.
-

6.7 SDC40G

 This address can be specified as system data area.

Device	Bit Address	Word Address	32 bit	Remarks
Data	00501.0-06100.F	00501-06100		*1

*1 When you write the bit address, the Display reads the word address corresponding to that of the External Device first. Then, it changes the target bit address among the word data once read and returns the word data to the External Device. Note that the correct data may not be written if you change the word address value in the ladder program while the Display reads the data of the External Device and returns it to the External Device.

IMPORTANT • To set [Enable System Data Area] in the system area setting of GP-Pro EX may cause malfunction. Do not set [Enable System Data Area].

NOTE • You can set only reading area size for the system data area available to use in the Controller. Please refer to the GP-Pro EX Reference Manual for reading area size.

Cf: GP-Pro EX Reference Manual "Appendix 1.4 LS Area (only for direct access method)"

- Please refer to the precautions on manual notation for icons in the table.
 - ☞ "Manual Symbols and Terminology"
 - Even if you use the nonexistent address, read error may not be displayed. In this case, "0" is retained for the read data. Note that the writing error is displayed.
-

6.8 DMC10

 This address can be specified as system data area.

Device	Bit Address	Word Address	32 bit	Remarks
Data	01001.0-07806.F	01001-07806		*1

*1 When you write the bit address, the Display reads the word address corresponding to that of the External Device first. Then, it changes the target bit address among the word data once read and returns the word data to the External Device. Note that the correct data may not be written if you change the word address value in the ladder program while the Display reads the data of the External Device and returns it to the External Device.

IMPORTANT • To set [Enable System Data Area] in the system area setting of GP-Pro EX may cause malfunction. Do not set [Enable System Data Area].

NOTE • You can set only reading area size for the system data area available to use in the Controller. Please refer to the GP-Pro EX Reference Manual for reading area size.

Cf: GP-Pro EX Reference Manual "Appendix 1.4 LS Area (only for direct access method)"

- Please refer to the precautions on manual notation for icons in the table.
 - ☞ "Manual Symbols and Terminology"
 - Even if you use the nonexistent address, read error may not be displayed. In this case, "0" is retained for the read data. Note that the writing error is displayed.
-

6.9 DCP31/DCP32

 This address can be specified as system data area.

Device	Bit Address	Word Address	32 bit	Remarks
Data	00501.0-04600.F	00501-04600		*1

*1 When you write the bit address, the Display reads the word address corresponding to that of the External Device first. Then, it changes the target bit address among the word data once read and returns the word data to the External Device. Note that the correct data may not be written if you change the word address value in the ladder program while the Display reads the data of the External Device and returns it to the External Device.

IMPORTANT

- To set [Enable System Data Area] in the system area setting of GP-Pro EX may cause malfunction. Do not set [Enable System Data Area].

NOTE

- You can set only reading area size for the system data area available to use in the Controller. Please refer to the GP-Pro EX Reference Manual for reading area size.

Cf: GP-Pro EX Reference Manual "Appendix 1.4 LS Area (only for direct access method)"

- Please refer to the precautions on manual notation for icons in the table.
 -  "Manual Symbols and Terminology"
- Even if you use the nonexistent address, read error may not be displayed. In this case, "0" is retained for the read data. Note that the writing error is displayed.

6.10 DCP551

 This address can be specified as system data area.

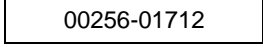
Device	Bit Address	Word Address	32 bit	Remarks
Data	00256.0-01712.F	00256-01712		*1

*1 When you write the bit address, the Display reads the word address corresponding to that of the External Device first. Then, it changes the target bit address among the word data once read and returns the word data to the External Device. Note that the correct data may not be written if you change the word address value in the ladder program while the Display reads the data of the External Device and returns it to the External Device.

IMPORTA • To set [Enable System Data Area] in the system area setting of GP-Pro EX may cause malfunction. Do not set [Enable System Data Area].

NOTE • You can set only reading area size for the system data area available to use in the Controller. Please refer to the GP-Pro EX Reference Manual for reading area size.

Cf: GP-Pro EX Reference Manual "Appendix 1.4 LS Area (only for direct access method)"

- Please refer to the precautions on manual notation for icons in the table.
 - ☞ "Manual Symbols and Terminology"
 - Even if you use the nonexistent address, read error may not be displayed. In this case, "0" is retained for the read data. Note that the writing error is displayed.
-

6.11 DCP552

 This address can be specified as system data area.

Device	Bit Address	Word Address	32 bit	Remarks
Data	00256.0-02003.F	00256-02003		*1

*1 When you write the bit address, the Display reads the word address corresponding to that of the External Device first. Then, it changes the target bit address among the word data once read and returns the word data to the External Device. Note that the correct data may not be written if you change the word address value in the ladder program while the Display reads the data of the External Device and returns it to the External Device.

IMPORTANT • To set [Enable System Data Area] in the system area setting of GP-Pro EX may cause malfunction. Do not set [Enable System Data Area].

NOTE • You can set only reading area size for the system data area available to use in the Controller. Please refer to the GP-Pro EX Reference Manual for reading area size.

Cf: GP-Pro EX Reference Manual "Appendix 1.4 LS Area (only for direct access method)"

- Please refer to the precautions on manual notation for icons in the table.
 "Manual Symbols and Terminology"
 - Even if you use the nonexistent address, read error may not be displayed. In this case, "0" is retained for the read data. Note that the writing error is displayed.
-

7 Device Code and Address Code

Use device code and address code when you select "Device Type & Address" for the address type in data displays. Address of the External Device is configured as follows.

7.1 SDC10

Device	Device Name	Device Code (HEX)	Address Code
Data	---	0080	Word Address

7.2 SDC15/SDC25/SDC26/SDC35/SDC36

Device	Device Name	Device Code (HEX)	Address Code
Data	---	0080	Word Address

7.3 SDC20/SDC21

Device	Device Name	Device Code (HEX)	Address Code
Data	---	0080	Word Address

7.4 SDC30/SDC31

Device	Device Name	Device Code (HEX)	Address Code
Data	---	0080	Word Address

7.5 SDC40A

Device	Device Name	Device Code (HEX)	Address Code
Data	---	0080	Word Address

7.6 SDC40B

Device	Device Name	Device Code (HEX)	Address Code
Data	---	0080	Word Address

7.7 SDC40G

Device	Device Name	Device Code (HEX)	Address Code
Data	---	0080	Word Address

7.8 DMC10

Device	Device Name	Device Code (HEX)	Address Code
Data	---	0080	Word Address

7.9 DCP31/DCP32

Device	Device Name	Device Code (HEX)	Address Code
Data	---	0080	Word Address

7.10 DCP551

Device	Device Name	Device Code (HEX)	Address Code
Data	---	0080	Word Address

7.11 DCP552

Device	Device Name	Device Code (HEX)	Address Code
Data	---	0080	Word Address

8 Error Messages

Error messages are displayed on the screen of Display as follows: "No. : Device Name: Error Message(Error Occurrence Area)". Each description is shown below.

Item	Requirements
No.	Error No.
Device Name	Name of External Device where error occurs. Name of External Device is a title of External Device set with GP-Pro EX.(Initial value[PLC1])
Error Message	Displays messages related to the error which occurs.
Error Occurrence Area	Displays IP address or device address of External Device where error occurs, or error codes received from External Device. <div style="border: 1px solid black; padding: 2px; display: inline-block;">NOTE</div> <ul style="list-style-type: none"> • IP address is displayed such as "IP address(Decimal): MAC address(Hex)". • Device address is displayed such as "Address: Device addressi. • Received error codes are displayed such as "Decimal[Hex]".

Display Examples of Error Messages

"RHAA035: PLC1: Error has been responded for device write command (Error Code: 2[02H])"

NOTE

- Please refer to the manual of External Device for more detail of received error codes.
- Please refer to "When an error message is displayed (Error code list)" of "Maintenance/Troubleshooting" for a common error message to the driver.