

Pro-face®

GP3000 Series
Hardware Manual

Preface

Thank you for purchasing Pro-face's GP3000 Series Programmable Operator Interface (Hereafter referred to as the “GP unit”).

Before operating your GP unit, be sure to read this manual to familiarize yourself with the GP unit's operation procedures and features.

NOTICE

1. Copying this manual's contents, either in whole or in part, is prohibited without the express permission of Digital Electronics Corporation, Japan.
2. The information contained in this manual is subject to change without notice.
3. If you should you find any errors or omissions in this document, please contact Digital Electronics Corporation to report your findings.
4. Regardless of Clause 3 above, Digital Electronics Corporation shall not be held responsible for any damages, losses or third-party damages resulting from the use of this product.

© 2005 Copyright Digital Electronics Corporation. All rights reserved.





Product names used in this manual are the trademarks / registered trademarks of their respective owners.

Essential Safety Precautions

All safety-related procedures stated in this document must be followed to operate the GP correctly and safely. Be sure to read this and any related documents thoroughly to understand the correct operation and functions of the GP unit.

Safety Icons

Throughout this manual, these icons provide essential safety information for GP operation procedures requiring special attention. These icons indicate the following levels of danger:

 WARNING	Indicates situations where severe bodily injury, death or major equipment damage can occur.
 CAUTION	Indicates situations where slight bodily injury or minor equipment damage can occur.
	Indicates actions or procedures that should NOT be performed.
	Indicates actions or procedures that MUST be performed to ensure correct unit operation.

WARNING

System Design

 Be sure to design your GP control system so that, in the event of a main power supply failure or a GP accident, the user system's overall safety integrity will be maintained. If this is not done, incorrect output signals or a GP malfunction may cause an accident.

- 1) Interlock and other circuits designed to interrupt or oppose normal machine movement (such as Emergency Stop, General Protection, and forward and reverse rotation), as well as those designed to prevent machine damage (such as upper, lower, and traverse movement limit positioning) should all be designed to be located outside of the GP.
- 2) When the GP generates a "Watchdog Timer Error," GP operation will halt. Also, when Errors occur in Input/Output control areas that the GP cannot detect, unexpected movement may occur in those areas. Therefore, and to prevent unsafe machine movement, a "Failsafe Circuit" should be created which is completely external to the GP.
For a failsafe circuit, refer to "7.2.5 Installation Precautions" (page 7-15).
- 3) If a problem arises with an external unit's relay or transistor, causing an output (coil) to remain either ON or OFF, a major accident can occur. To prevent this, be sure to set up external watchdog circuits that will monitor vital output signals.

- ❗ Design a circuit that will supply power to the GP unit's I/O before starting up the GP. If the GP unit's internal program enters RUN mode prior to the I/O unit's load control power turning ON, an incorrect output (signal) or malfunction could cause an accident.
- ❗ Design a user program that ensures the safety of the user's system, in the event of a GP display or control error, or either a data transmission error or power failure between the GP and a connected unit. These types of problems can lead to an incorrect output (signal) or malfunction, resulting in an accident.
- ⊘ Do not make switches using the switches on the touch panels which may cause operator injury and machine damage. An output may remain either ON or OFF and a major accident can occur. To prevent this, set up circuits such as limiters that will monitor vital output signals. Design switches for important operations to be performed by separate devices. An incorrect output or malfunction can occur and thereby cause an accident.
- ⊘ Do not create GP touch panel switches to control machine safety operations, such as an emergency stop switch. Install these switches as separate hardware switches, otherwise severe bodily injury or equipment damage can occur.
- ❗ Be sure to design your system so that a communication fault between the GP and its host controller will not cause equipment to malfunction. This is to prevent any possibility of bodily injury or equipment damage.
- ⊘ Do not use the GP as a warning device for critical alarms that can cause serious operator injury, machine damage or can halt system operation. Critical alarm indicators and their control/activator units must be designed using stand-alone hardware and/or mechanical interlocks.
- ⊘ Do not use the GP with aircraft control devices, aerospace equipment, central trunk data transmission (communication) devices, nuclear power control devices, or medical life support equipment, due to these devices' inherent requirements of extremely high levels of safety and reliability.
- ❗ Be sure to design your system so that a communication fault between the GP and its host controller will not cause equipment to malfunction. This is to prevent any possibility of bodily injury or equipment damage.

- ⊘ After the GP unit's backlight burns out the touch panel is still active, unlike the GP unit's "Standby Mode". If the operator fails to notice that the backlight is burned out and touches the panel, a potentially dangerous machine operation error can occur. Therefore, do not create GP unit touch panel switches that may cause injury and/or equipment damage. If your GP unit's backlight suddenly turns OFF, use the following steps to determine if the backlight is actually burned out.
 - 1) If the GP unit's "Backlight Control" is not set and the screen has gone blank, your backlight is burned out.
 - 2) If the GP unit's "Backlight Control" is set to Standby Mode and the screen has gone blank, and touching the screen or performing another input operation does not cause the display to reappear, your backlight is burned out.

Handling

- ⊘ Do not disassemble or modify the GP unit. Doing so may cause a fire or an electric shock.
- ⊘ Do not operate the GP in an environment where flammable gases are present, since it may cause an explosion.

Wiring

- ⚠ To prevent electrical shock or equipment damage, unplug the GP unit's power cord from the power supply prior to installing or wiring the GP.
- ⚠ After completing any GP wiring work, be sure the terminal block's protective plastic cover is reattached. If this cover is not reattached, an electrical shock could easily occur.
- ⚠ To prevent an electric shock be sure to disconnect your GP unit's power cord from the power supply before wiring the GP.
- ⊘ Do not use voltage beyond the GP unit's specified range. Doing so may cause a fire or an electric shock.
- ⚠ The cables connected to the GP should be secured by cable clamps to prevent weight or tension of the cables added to the connectors or terminals.
- ⚠ The GP unit's wiring should be checked to confirm that both the operating voltage and wiring terminal locations are correct. If either the voltage or the wiring terminal location is incorrect, it can cause a fire or accident.

Maintenance

- ⊘ NEVER touch a live power terminal. Doing so could cause an electrical shock or a machine malfunction.
- ⊘ To prevent an electrical shock, unplug the GP unit's power cord before either cleaning the GP or attaching/detaching the power terminal attachment screws.
- ⊘ When replacing the GP unit's backlight, be sure to unplug the unit's power cord to prevent an electrical shock, and wear safety gloves to prevent burns.

- ⊘ Do not connect or disconnect Host and GP unit communication cables while the GP is turned ON.
- ⊘ Do not replace the GP unit's battery yourself. The GP uses a lithium battery for backing up its internal clock data and the battery may explode if it is replaced incorrectly. When replacement is required, please contact your local GP distributor.

⚠ CAUTION

Wiring Layout Precautions

- ⚠ To prevent a GP unit malfunction due to excessive noise, isolate all GP input/output signal lines from all power wiring or power cables via a separate wiring duct.

Installation

- ⚠ Be sure all cable connectors are securely attached to the GP unit. A loose connection may cause incorrect input or output signals.

Wiring

- ⚠ Be sure to ground the GP unit's FG wire separately from other equipment FG lines. Also, be sure to use a grounding resistance of 100. or less and a 2mm² [0.0062inch²] or thicker wire, or your country's applicable standard. Otherwise, electric shock or malfunctions may result.
- ⚠ Be sure to use only the designated torque to tighten the GP unit's terminal block screws. If these screws are not tightened firmly, it may cause a short-circuit, fire or incorrect unit operation.
- ⚠ Be sure that metal particles and wiring debris do not fall inside the GP unit. They can cause a fire, malfunction or incorrect unit operation.

Maintenance

- ⚠ Be sure to read the GP unit's manual carefully before performing program changes, entering forced output, or using the RUN, STOP, or PAUSE commands while the GP is operating. Mistakes made when using these items can cause machine accidents or damage.
- ⚠ Be sure the electricity is turned OFF before attaching or detaching an I/O unit. If the electricity is ON when an I/O unit is attached or detached, damage or malfunction to the I/O unit may occur.
- ⊘ Be sure to turn the GP unit's CF Card ACCESS switch OFF and confirm that the ACCESS lamp is not lit prior to inserting or removing a CF Card. Otherwise, CF Card internal data may be damaged or lost.
- ⊘ Do not reset or turn the GP OFF, or insert or remove the CF Card while the GP unit's CF Card is being accessed. Create special application screens to perform operations like turning power OFF, resetting the GP or inserting or removing the CF Card.

Unit Disposal

- ❗ When the product is disposed of, it should be done so according to your country's regulations for similar types of industrial waste.

General Safety Precautions

- ⊘ Do not press on the GP unit's display with excessive force or with a hard object, since it can damage the display. Also, do not press on the touch panel with a pointed object, such as the tip of a mechanical pencil or a screwdriver, since doing so can damage the touch panel.
- ⊘ Do not install the GP where the ambient temperature exceeds the specified range. Doing so may cause a unit malfunction.
- ⊘ To prevent abnormally high temperatures from occurring inside the GP, do not restrict or block the GP unit's rear-face ventilation slots.
- ⊘ Do not operate the GP in areas where large, sudden temperature changes can occur. These changes can cause condensation to form inside the GP, possibly causing it to malfunction.
- ⊘ Do not allow water, liquids or metal fragments to enter inside the GP unit's case, since they can cause either a malfunction or an electric shock. The allowable pollution degree is 2.
- ⊘ Do not operate or store the GP in locations where it can be exposed to direct sunlight, high temperatures, excessive dust, moisture or vibration.
- ⊘ Do not operate or store the GP where chemicals evaporate, or where chemicals are present in the air.
Corrosive chemicals: Acids, alkalines, liquids containing salt
Flammable chemicals: Organic Solvents
- ⊘ Do not use paint thinner or organic solvents to remove dirt or oil from the GP unit's surface. Instead, use a soft cloth moistened with a diluted neutral detergent.
- ⊘ Do not use or store the GP in areas with direct sunlight, since the sun's ultraviolet rays may cause the LCD's quality to deteriorate.
- ❗ Do not store the GP in an area where the temperature is lower than that recommended in the GP unit's specifications. Doing so may cause the LCD display's liquid to congeal, which can damage the LCD. Also, if the storage area's temperature becomes higher than the specified level, the LCD's liquid may become isotropic, causing irreversible damage to the LCD. Therefore, only store the GP in areas where temperatures are within the GP unit's specifications.
- ❗ After turning OFF the GP, be sure to wait a few seconds before turning it ON again. The GP may not operate correctly if it is restarted too quickly.
- ❗ Be sure to back up the GP screen data and logic programs in case they are lost accidentally.

LCD Panel Usage Precautions

- The LCD panel's liquid contains an irritant. If the panel is damaged and any of this liquid contacts your skin, immediately rinse the area with running water for at least 15 minutes. If the liquid gets in your eyes, immediately rinse your eyes with running water for at least 15 minutes and consult a doctor.
- The GP unit's LCD screen may flicker or show unevenness in the brightness of certain images or at some contrast settings. This is an LCD characteristic and not a product defect.
- There's an individual difference in brightness and tone of LCD screen. Please be aware of this difference before using the lined-up plural units.
- The GP unit's LCD screen pixels may contain minute black and white-colored spots. This is an LCD characteristic and not a product defect.
- Extended shadows, or "Crosstalk" may appear on the sides of screen images. This is an LCD characteristic and not a product defect.
- The color displayed on the GP unit's LCD screen may appear different when seen from outside the specified viewing angle. This is an LCD characteristic and not a product defect.
- When the same image is displayed on the GP unit's screen for a long period, an afterimage may appear when the image is changed. If this happens, turn off the GP, wait 10 seconds and then restart the unit. This is an LCD characteristic and not a product defect.
- To prevent an afterimage:
 - * Set the GP unit's display OFF feature when you plan to display the same screen image for a long period of time.
 - * Change the screen image periodically and try to not display the same image for a long period of time.

Information Symbols

This manual uses the following icons:

IMPORTANT	Indicates a warning or a product limitation. Be sure to follow the instructions given with this icon to ensure the safe operation of the GP.
Screen Editor	Indicates the GP-Pro EX software.
PLC	Abbreviation for Programmable Logic Controller.
Logic program	Indicates a ladder program created with the GP-Pro Ex.
*	Indicates useful or important supplemental information.
NOTE	Contains additional or useful information.
SEE →	Indicates pages containing related information.

GP3000 Series Model Name Indication

Model name

AGP3 ^{***} - ^{*} **1** - ^{***} - ^{****}
_{A B C} _{D E}

A	2	GP-3200 series (3.8-inch): QVGA (320 x 240 dots)
	3	GP-3300 series (5.7-inch): QVGA (320 x 240 dots)
	4	GP-3400 series (7.5-inch): VGA (640 x 480 dots)
	5	GP-3500 series (10.4-inch) ^{*1} : VGA (640 x 480 dots),SVGA(800 x 600 dots) ^{*2}
	6	GP-3600 series (12.1-inch): SVGA (800 x 600 dots)
	7	GP-3700 series (15-inch): XGA (1024 x 768 dots)
	B	00
10 ^{*2}		
01		Low-cost machine
02		
50		
60 ^{*2}	Multimedia machine	
C	A	Monochrome amber/red mode LCD
	B	Monochrome blue mode LCD
	L	Monochrome LCD
	S	STN color LCD
	T	TFT color LCD
D	AF	AC type power supply is used.
	D24	DC type power supply is used.
E	Omitted	Standard type
	D81K	DIO board type (sink type)
	D81C	DIO board type (source type)
	FN1M	FLEX NETWORK board type

^{*1} The AGP-3500L and The AGP-3500S have the same dimensions as a 12.1-inch display unit.

^{*2} AGP-3510T/3560T only.



GP3000 Series Model Names

The term "GP3000" Series refers to the following GP model numbers:

Series	Names	Models	
GP3000 series	GP-3200 series	AGP-3200A	AGP3200-A1-D24
		AGP-3200T	AGP3200-T1-D24
	GP-3300 series	AGP-3300L	AGP3300-L1-D24 AGP3300-L1-D24-D81K AGP3300-L1-D24-D81C AGP3300-L1-D24-FN1M
		AGP-3300S	AGP3300-S1-D24 AGP3300-S1-D24-D81K AGP3300-S1-D24-D81C
		AGP-3300T	AGP3300-T1-D24 AGP3300-T1-D24-D81K AGP3300-T1-D24-D81C AGP3300-T1-D24-FN1M
		AGP-3301L	AGP3301-L1-D24
		AGP-3301S	AGP3301-S1-D24
		AGP-3302B	AGP3302-B1-D24
		GP-3400 series	AGP-3400S
	AGP-3400T		AGP3400-T1-D24 AGP3400-T1-D24-D81K AGP3400-T1-D24-D81C AGP3400-T1-D24-FN1M
	AGP-3450T		AGP3450-T1-D24
	GP-3500 series	AGP-3500L	AGP3500-L1-D24 AGP3500-L1-D24-D81C
		AGP-3500S	AGP3500-S1-AF AGP3500-S1-AF-D81K AGP3500-S1-AF-D81C
			AGP3500-S1-D24 AGP3500-S1-D24-D81K AGP3500-S1-D24-D81C
		AGP-3500T	AGP3500-T1-AF AGP3500-T1-AF-D81K AGP3500-T1-AF-D81C AGP3500-T1-AF-FN1M
			AGP3500-T1-D24 AGP3500-T1-D24-D81K AGP3500-T1-D24-D81C AGP3500-T1-D24-FN1M
		AGP-3510T	AGP3510-T1-AF
		AGP-3550T	AGP3550-T1-AF
		AGP-3560T	AGP3560-T1-AF
	GP-3600 series	AGP-3600T	AGP3600-T1-AF AGP3600-T1-AF-D81K AGP3600-T1-AF-D81C AGP3600-T1-AF-FN1M
			AGP3600-T1-D24 AGP3600-T1-D24-D81K AGP3600-T1-D24-D81C AGP3600-T1-D24-FN1M
		AGP-3650T	AGP3650-T1-AF
	GP-3700 series	AGP-3750T	AGP3750-T1-AF
			AGP3750-T1-D24

Package Contents

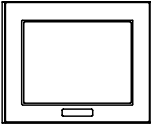
The following items are included in the GP unit's package. Before using the GP, please check that all items listed here are present.

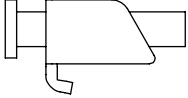
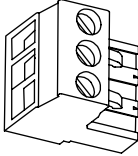
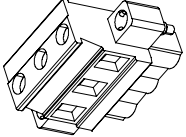
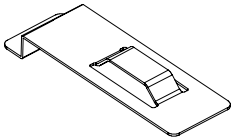
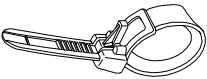
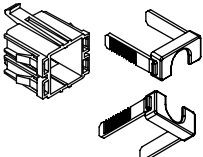
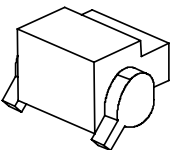
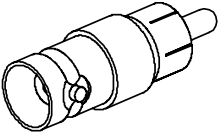
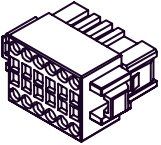
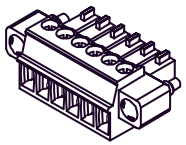
<p>GP Unit: 1</p> 	<ul style="list-style-type: none"> English and Japanese Installation Guides (1 of each) Warning/Caution Information (1) 	<p>Installation Gasket: 1</p> <p>(Attached to the GP unit)</p> 	<p>Installation Fasteners: 4 per set</p> <p>(GP-3700 series only: 4 x 2 sets)</p> 
<p>DC Power Connector: 1</p> <ul style="list-style-type: none"> GP-3200/3300/3400 series (Attached to the GP unit for GP-3200/3300 series) GP-3500/3600/3700 series (Attached to the GP unit)  			
<p>USB Cable Clamp 1 set</p> <ul style="list-style-type: none"> GP-3300 series Holder: 1, Clamp: 1 GP3000 series except GP-3300 series Holder: 1, Cover: 2 (GP-3200 series only: Holder: 1, Cover: 1)   			
<p>AUX Connector: 1</p> <ul style="list-style-type: none"> GP3000 series except GP-3200/3300 series <p>(Attached to the GP unit for GP-3500/3600/3700 series)</p> 	<p>RCA-BNC Converter: 1</p> <ul style="list-style-type: none"> GP-3*50 series/AGP-3560T only 		
<p>DIO Connector 1, Installation Guide 1</p> <ul style="list-style-type: none"> DIO board type only 	<p>FLEX NETWORK Connector 1, Installation Guide 1</p> <ul style="list-style-type: none"> FLEX NETWORK board type only 		

This unit has been carefully packed, with special attention to quality. However, should you find anything damaged or missing, please contact your local GP distributor immediately.

UL/c-UL/CSA Approval

The following units are UL/c-UL/CSA listed products.

(UL File No.E220851, UL File No.E182139, CSA File No.219866)

Product Model No.*1	UL/c-UL/CSA Registration Model No.
AGP3300-L1-D24-****	3280007-03
AGP3300-S1-D24-****	3280007-02
AGP3300-T1-D24-****	3280007-01
AGP3301-L1-D24	3280007-13
AGP3301-S1-D24	3280007-12
AGP3302-B1-D24	3280007-24
AGP3400-T1-D24-****	3280035-01
AGP3400-S1-D24-****	3280035-02
AGP3450-T1-D24	3280035-31

*1 Additional four digits at the end of the model name do not affect the registration model No. For example, AGP3300-L1-D24 and AGP3300-L1-D24-D81K are approved for the same UL/c-UL/CSA registration model No. of 3280007-03.

This product conforms to the following standards:

- UL508 Industrial Control Equipment
- UL1604 Electrical Equipment for use in Class I and II, Division 2, and Class III Hazardous (classified) locations.
- CSA-C22.2 No.14-M95 Industrial Control Equipment
- CSA-C22.2 No.213-M1987 Non-incendive Electrical Equipment for Use in Class I, Division 2 Hazardous Locations.

The following units are UL/c-UL listed products. (UL File No.E171486, UL File No.E231702)

Product Model No.*1	UL/c-UL Registration Model No.
AGP3500-S1-AF-****	3280024-21
AGP3500-T1-AF-****	3280035-45
AGP3510-T1-AF	3581301-01
AGP3550-T1-AF	3280035-75
AGP3560-T1-AF	3581301-03
AGP3600-T1-AF-****	3280024-13
AGP3650-T1-AF	3280024-11
AGP3750-T1-AF	3280024-01

- *1 Additional four digits at the end of the model name do not affect the registration model No. For example, AGP3500-S1-AF and AGP3500-S1-AF-D81K are approved for the same UL/c-UL registration model No. of 3280024-21.

This product conforms to the following standards:

- UL60950-1 Information Technology Equipment - Safety - Part 1
- UL1604 Electrical Equipment for use in Class I and II, Division 2, and Class III Hazardous (classified) locations.
- CAN/CSA-C22.2 No.60950-1-03 (c-UL approval)
Information Technology Equipment - Safety - Part 1
- CSA-C22.2 No.213-M1987 (c-UL approval)
Non-incendive Electrical Equipment for Use in Class I, Division 2 Hazardous Locations.

The following units are UL/c-UL/CSA listed products.

(UL File No.E220851, UL File No.E210412, CSA File No.219866)

Product Model No. *1	UL/c-UL/CSA Registration Model No.
AGP3200-A1-D24	3580205-03
AGP3200-T1-D24	3580205-04
AGP3500-L1-D24-****	3280024-32
AGP3500-S1-D24-****	3280024-22
AGP3500-T1-D24-****	3280035-41
AGP3600-T1-D24-****	3280024-14
AGP3750-T1-D24	3280024-02

- *1 Additional four digits at the end of the model name do not affect the registration model No. For example, AGP3500-T1-D24 and AGP3500-T1-D24-D81K are approved for the same UL/c-UL/CSA registration model No. of 3280035-41.

This product conforms to the following standards:

- UL508 Industrial Control Equipment
- UL1604 Electrical Equipment for use in Class I and II, Division 2, and Class III Hazardous (classified) locations.
- CSA-C22.2 No.14-M95 Industrial Control Equipment
- CSA-C22.2 No.213-M1987 Non-incendive Electrical Equipment for Use in Class I, Division 2 Hazardous Locations.

<Cautions>

Be aware of the following items when building the GP into an end-use product:

- The GP unit's rear face is not approved as an enclosure. When building the GP unit into an end-use product, be sure to use an enclosure that satisfies standards as the end-use product's overall enclosure.
- The GP unit must be used indoors only.
- Install and operate the GP with its front panel facing outwards.
- If the GP is mounted so as to cool itself naturally, be sure to install it in a vertical panel. Also, it's recommended that the GP should be mounted at least 100 mm away from any other adjacent structures or machine parts. The temperature must be checked on the final product in which the GP is installed.
- Serial Interface (COM2) is not Limited Power Source.
- For use on a flat surface of a Type 4X (Indoor Use Only) and/or Type 13 Enclosure.

<UL1604/CSA-C22.2, No.213 - Compliance and Handling Cautions>

- (1) Power and input/output wiring must be in accordance with Class I, Division 2 wiring methods - Article 501-4(b) of the National Electrical Code, NFPA 70 within the United States, and in accordance with Section 18-152 of the Canadian Electrical Code for units installed within Canada.
- (2) Suitable for use in Class I, Division 2, Groups A, B, C, and D Hazardous Locations, or Non-Hazardous Locations.
- (3) WARNING: Explosion hazard-substitution of components may impair compliance to Class I, Division 2
- (4) WARNING: Explosion hazard-when in hazardous locations, turn the power OFF before replacing or wiring modules.
- (5) WARNING: Explosion hazard-confirm that the power supply has been turned OFF before disconnecting equipment, or confirm that the location is not subject to the risk of explosion.
- (6) WARNING: Explosion hazard-do not disconnect equipment unless power has been switched off or the area is known to be Non-Hazardous.
- (7) In the case of use in Hazardous Locations, be sure to check that the externally connected unit and each interface have been fixed with screws and locked. In Hazardous Locations, it's impossible to insert or pull the cable from the applicable port. Be sure to check that the location is Non-Hazardous before inserting or pulling it.

CE Marking

The following units are CE marked products complying with the EMC Directive.

They comply with EN55011 Class A, EN61131-2.

AGP3200-A1-D24	AGP3200-T1-D24
----------------	----------------

The following units are CE marked products complying with the EMC Directive.*1

They comply with EN55011 Class A, EN61000-6-2.

AGP3300-L1-D24-****	AGP3300-S1-D24-****	AGP3300-T1-D24-****
AGP3301-L1-D24	AGP3301-S1-D24	AGP3302-B1-D24
AGP3400-S1-D24-****	AGP3400-T1-D24-****	AGP3450-T1-D24
AGP3500-L1-D24-****	AGP3500-S1-D24-****	AGP3500-T1-D24-****
AGP3600-T1-D24-****	AGP3750-T1-D24	

*1 Additional four digits at the end of the model name do not affect compliance. For example, AGP3500-T1-D24 and AGP3500-T1-D24-D81K are CE marked products complying with the same EMC Directive.

The following units are CE marked products complying with both the EMC Directive and low-voltage directive.*1

They comply with EN55011 Class A, EN61000-6-2 and EN60950-1.

AGP3500-S1-AF-****	AGP3500-T1-AF-****	AGP3510-T1-AF
AGP3550-T1-AF	AGP3560-T1-AF	AGP3600-T1-AF-****
AGP3650-T1-AF	AGP3750-T1-AF	

*1 Additional four digits at the end of the model name do not affect compliance. For example, AGP3500-T1-AF and AGP3500-T1-AF-D81K are CE marked products complying with the same EMC Directive and low-voltage directive.

Contents

Preface	1
Essential Safety Precautions.....	2
Information Symbols.....	8
GP3000 Series Model Name Indication	8
GP3000 Series Model Names.....	9
Package Contents	10
UL/c-UL/CSA Approval.....	11
CE Marking.....	14

Chapter 1 System Design

1.1 AGP-3300*/3301* and GP-3200/3400/3500/3600/3700 Series.....	1-2
1.2 AGP-3302*	1-8
1.3 DIO Board Type	1-12
1.4 FLEX NETWORK Board Type	1-12

Chapter 2 Accessories

2.1 Accessories	2-2
2.1.1 Serial Interface Item.....	2-2
2.1.2 USB Host Interface	2-3
2.1.3 CF Card Items	2-3
2.1.4 Option Items	2-4
2.1.5 Maintenance Items	2-4
2.1.6 Expansion Unit.....	2-5
2.2 Optional Item for the DIO Board Type	2-6
2.2.1 Maintenance Items	2-6
2.3 Optional Items for the FLEX NETWORK Board Type.....	2-6
2.3.1 I/O Units.....	2-6
2.3.2 Analog Units.....	2-7
2.3.3 Single-Axis Positioning Units	2-7
2.3.4 High-Speed Counter Unit.....	2-7
2.3.5 Optional Items.....	2-7
2.3.6 Maintenance Items	2-8

Chapter 3 Part Names and Functions

3.1 GP-3200 Series	3-2
3.2 GP-3300 Series	3-3
3.3 GP-3400 Series	3-6
3.4 GP-3500 Series	3-9
3.5 GP-3600 Series	3-12
3.6 GP-3700 Series	3-15

Chapter 4 Specifications

4.1 GP-3200 Series	4-2
4.1.1 General Specifications	4-2
4.1.2 Performance Specifications	4-4
4.1.3 Interface Specifications	4-6
4.1.4 Dimensions	4-8
4.2 GP-3300 Series	4-12
4.2.1 General Specifications	4-12
4.2.2 Performance Specifications	4-14
4.2.3 Interface Specifications	4-17
4.2.4 Dimensions	4-21
4.3 GP-3400 Series	4-26
4.3.1 General Specifications	4-26
4.3.2 Performance Specifications	4-28
4.3.3 Interface Specifications	4-31
4.3.4 Dimensions	4-34
4.4 GP-3500 Series	4-38
4.4.1 General Specifications	4-38
4.4.2 Performance Specifications	4-41
4.4.3 Interface Specifications	4-44
4.4.4 Dimensions	4-47
4.5 GP-3600 Series	4-54
4.5.1 General Specifications	4-54
4.5.2 Performance Specifications	4-57
4.5.3 Interface Specifications	4-60
4.5.4 Dimensions	4-63
4.6 GP-3700 Series	4-67
4.6.1 General Specifications	4-67
4.6.2 Performance Specifications	4-70
4.6.3 Interface Specifications	4-73
4.6.4 Dimensions	4-76

Chapter 5 DIO Connector

5.1 DIO Interface (Connector)	5-2
5.2 Wiring to the DIO Connector.....	5-6

Chapter 6 FLEX NETWORK Connector

6.1 FLEX NETWORK Specifications	6-2
6.1.1 FLEX NETWORK Interface (Connector).....	6-2
6.1.2 Flex Network Data Transfer Settings	6-3
6.2 Wiring to the FLEX NETWORK Connector.....	6-3
6.2.1 FLEX NETWORK Communication Cable	6-3
6.2.2 Wiring to the FLEX NETWORK Connector.....	6-4

Chapter 7 Installation and Wiring

7.1 Installation.....	7-2
7.2 Wiring Precautions.....	7-7
7.2.1 Connecting the Power Cord.....	7-7
7.2.2 Connecting the Power Supply	7-12
7.2.3 Grounding	7-13
7.2.4 Wiring Precautions.....	7-14
7.2.5 Installation Precautions.....	7-15
7.3 CF Card Insertion/Removal	7-18
7.3.1 Inserting the CF Card	7-19
7.3.2 Removing the CF Card	7-19
7.3.3 CF Card Handling	7-20
7.4 USB Cable Clamp Attachment/Removal	7-21
7.4.1 GP-3200 Series	7-21
7.4.2 GP-3300 Series	7-21
7.4.3 GP-3400/3500/3600/3700 Series	7-22
7.5 Attaching the AUX Connector.....	7-25

Chapter 8 Maintenance

8.1 Cleaning the Display	8-2
8.2 Periodic Check Points.....	8-3
8.3 Replacing the Installation Gasket	8-4
8.4 Replacing the Backlight	8-6
8.4.1 AGP-35*0T	8-6
8.4.2 AGP-3500S.....	8-16
8.4.3 AGP-3600T/3650T.....	8-20
8.4.4 AGP-3750T	8-24

1

System Design

1. AGP-3300*/3301* and GP-3200/3400/3500/3600/3700 Series
2. AGP-3302*
3. DIO Board Type
4. FLEX NETWORK Board Type

1.1 AGP-3300*/3301* and GP-3200/3400/3500/3600/3700 Series

The following diagram illustrates the standard range of items that can be connected to AGP-3300*/3301* and GP-3200/3400/3500/3600/3700 Series units.

For host controller (PLC, etc.) connection information, refer to the "GP-Pro EX Device/PLC Connection Manual".

◆GP RUN Mode Peripherals

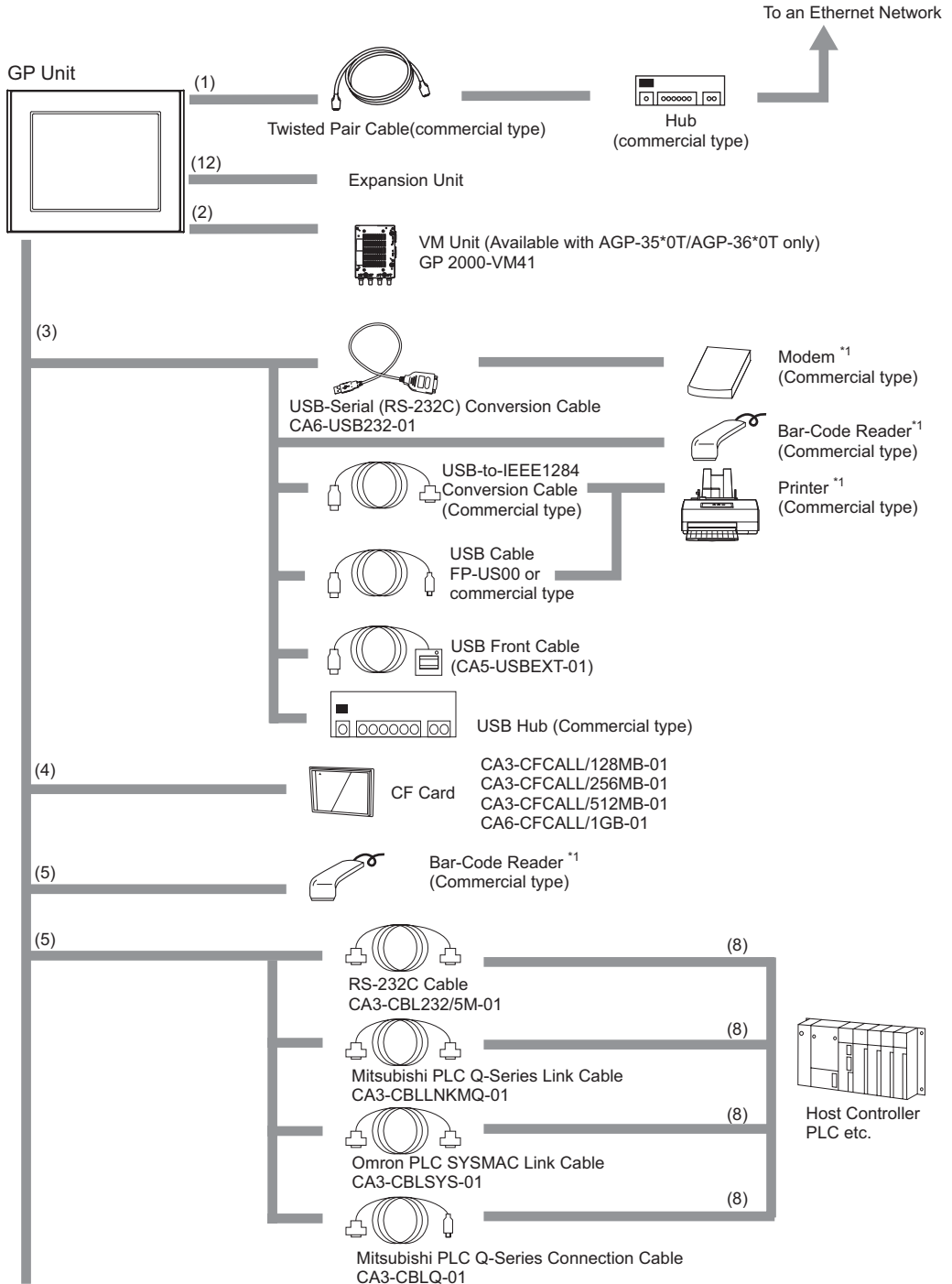

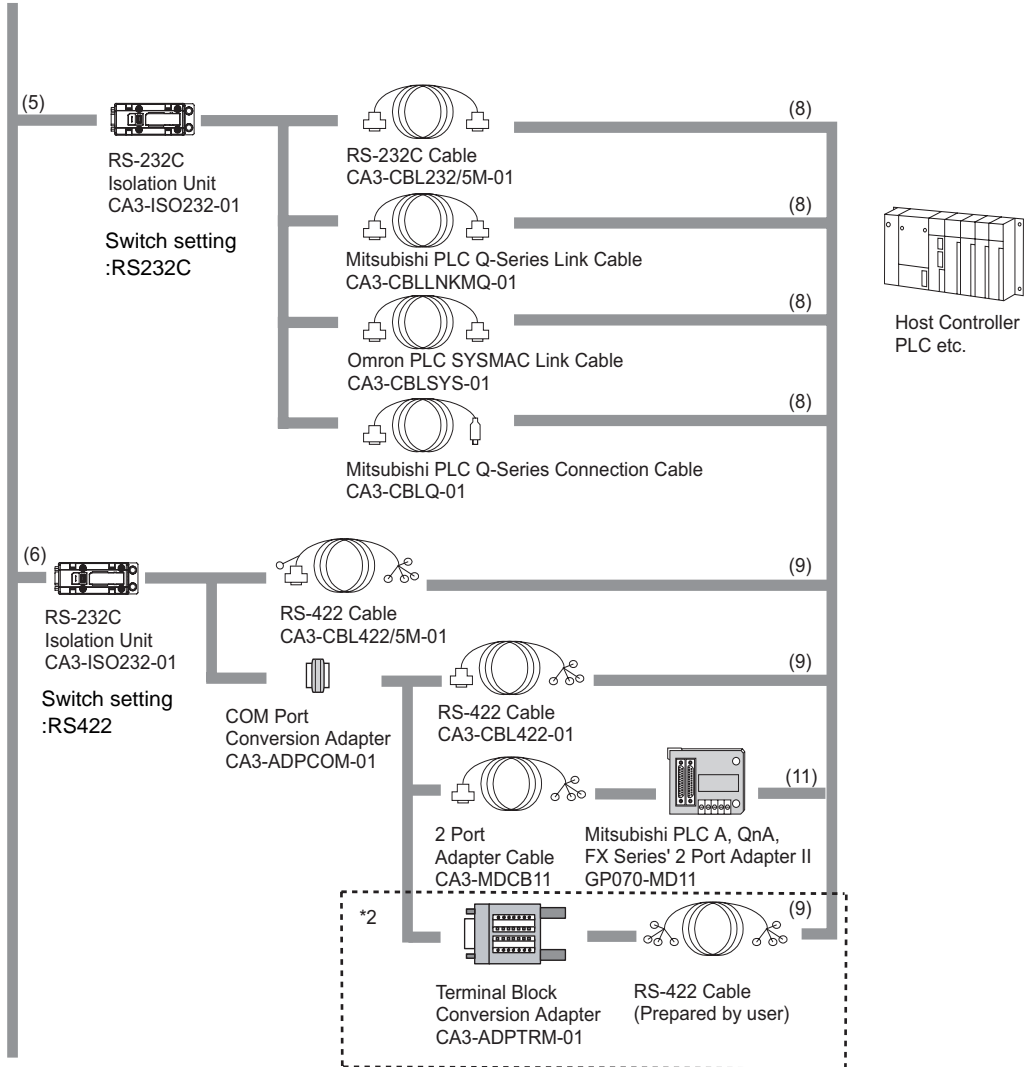

NOTE

- When connecting the CA3-ISO232-01, the 9 Pin's setting of COM port is required to be VCC. COM port settings can be set with the GP-Pro EX or in GP's offline mode.

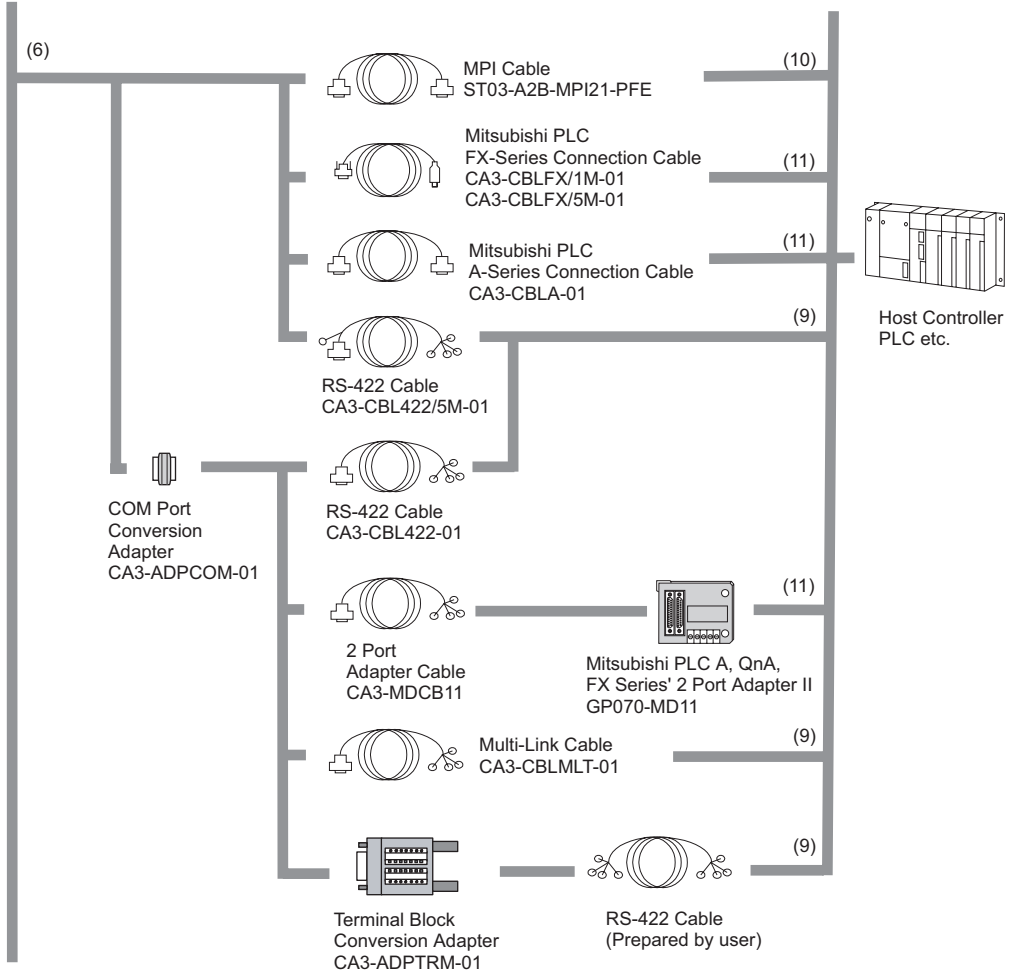

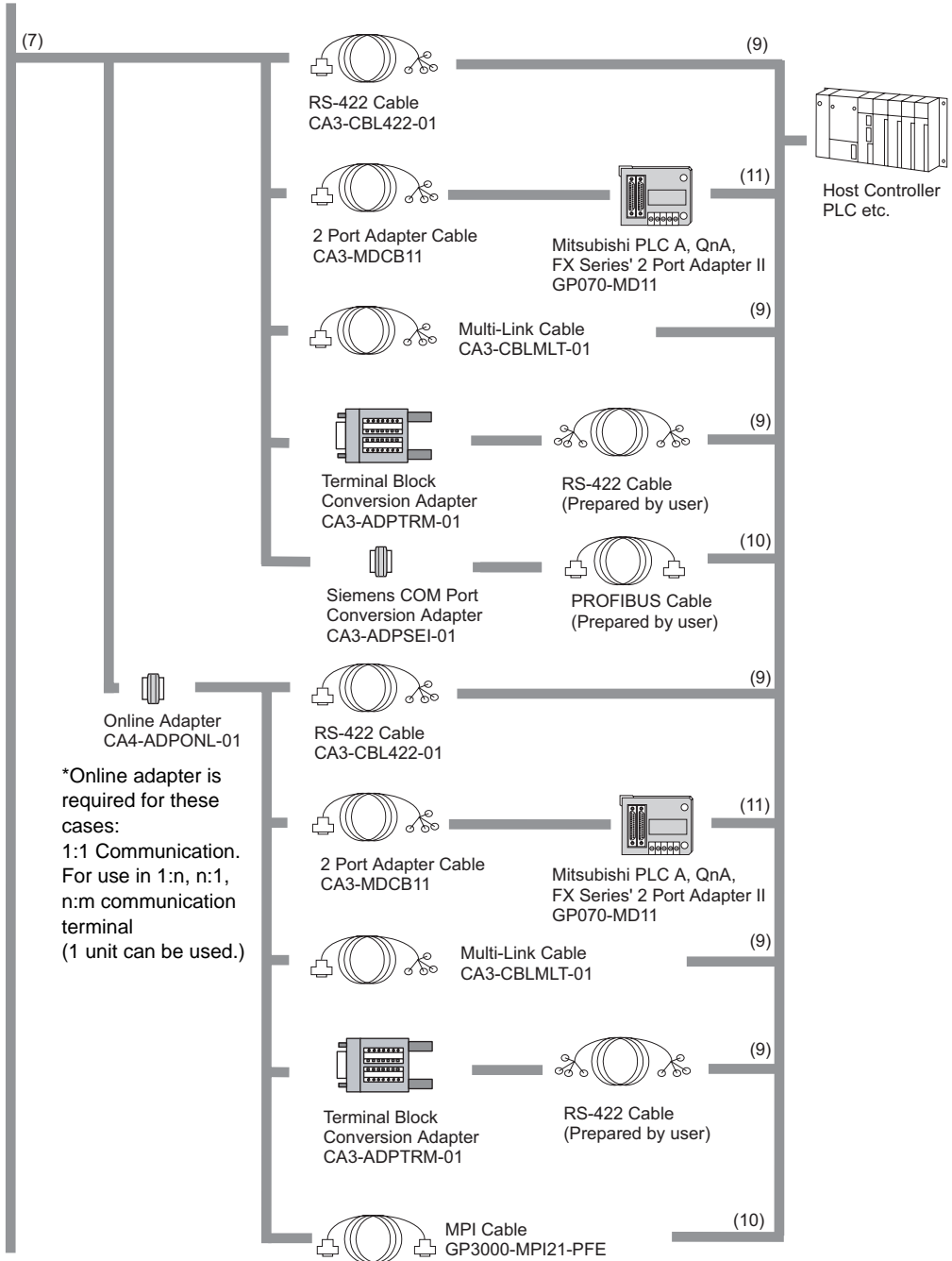

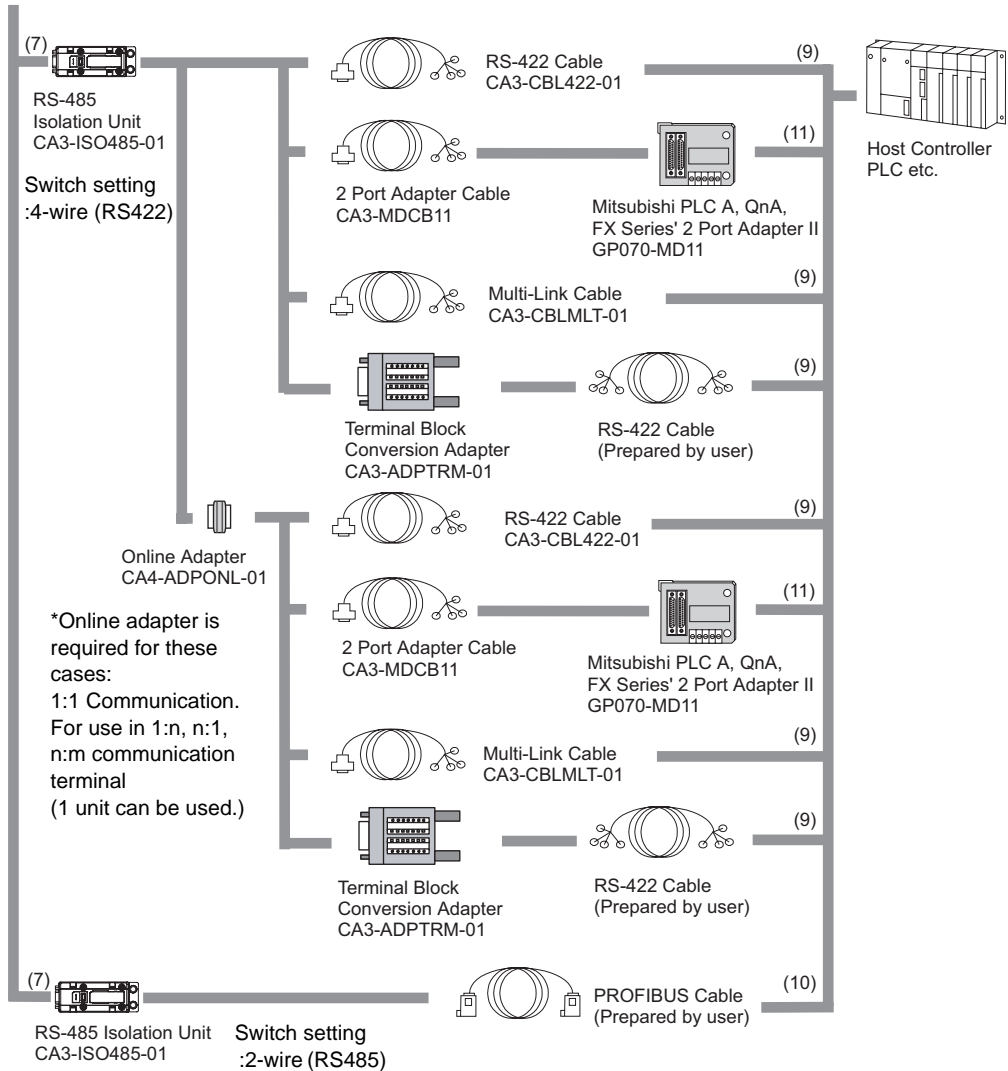

GP Interfaces	PLC Interfaces
(1) Ethernet Interface (10BASE-T/100BASE-TX) Not available with AGP-3301* units	(8) RS-232C Port
(2) VM Unit Interface	(9) RS-422 Port
(3) USB Host Interface	(10) RS-485 Port
(4) CF Card Interface	(11) Programming Console Port
(5) Serial Interface (COM1) (RS232C mode)	
(6) Serial Interface (COM1) (RS422 mode)	
(7) Serial Interface (COM2) Not available with GP-3200 series	
(12) Expansion Unit Interface Not available with GP-3200 series	

◆Edit Mode Peripherals

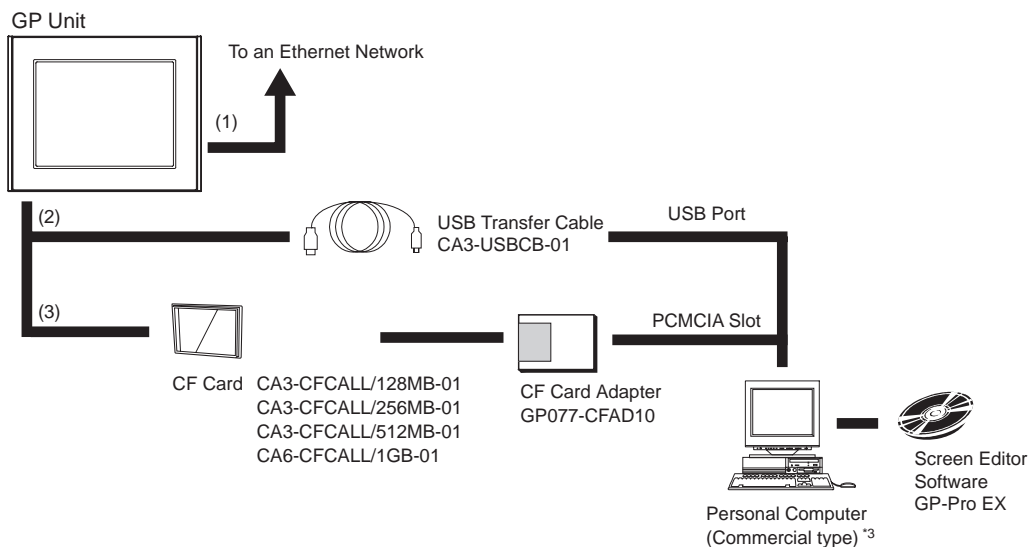

GP Interfaces

- (1) Ethernet Interface
(10BASE-T/100BASE-TX)
Not available with AGP-3301* units
- (2) USB Host Interface
- (3) CF Card Interface
Not available with GP-3200 series

*1 For supported models, refer to Pro-face's support site "Otasuke Pro!" (<http://www.pro-face.com/otasuke/>).

You can connect to this site by clicking the GP-Pro EX's [Help(H)] menu-[Connect to Support Site "Otasuke Pro!" (o)] command.

*2 GP-3200 series unit is compatible for the 4-wired 1:1 communication connection.

*3 Certain types and models of PCs cannot be used.



GP-Pro EX Reference Manual

1.2 AGP-3302*

The following diagram illustrates the standard range of items that can be connected to AGP-3302* units.

For host controller (PLC, etc.) connection information, refer to the "GP-Pro EX Device/PLC Connection Manual".

◆GP RUN Mode Peripherals

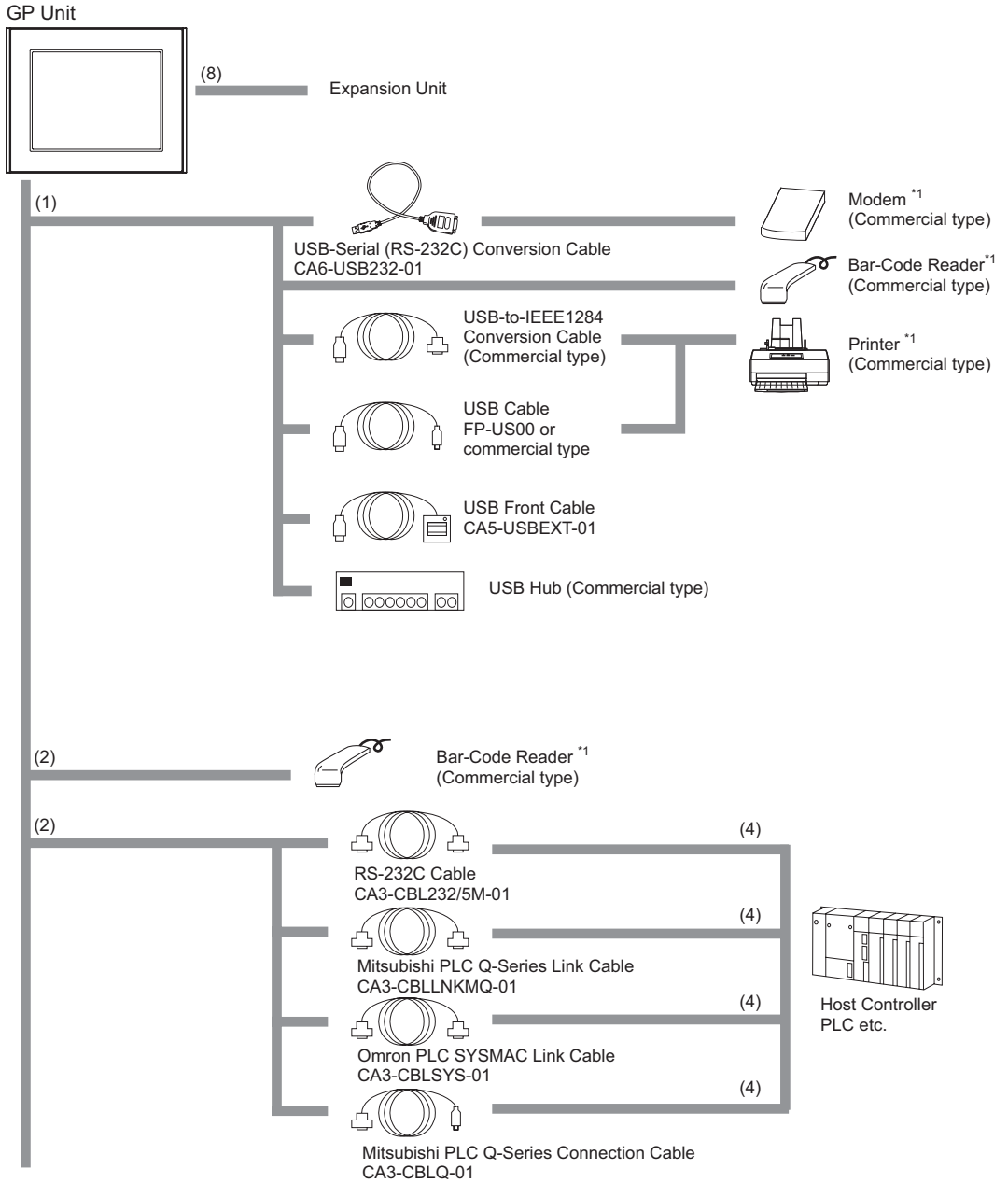

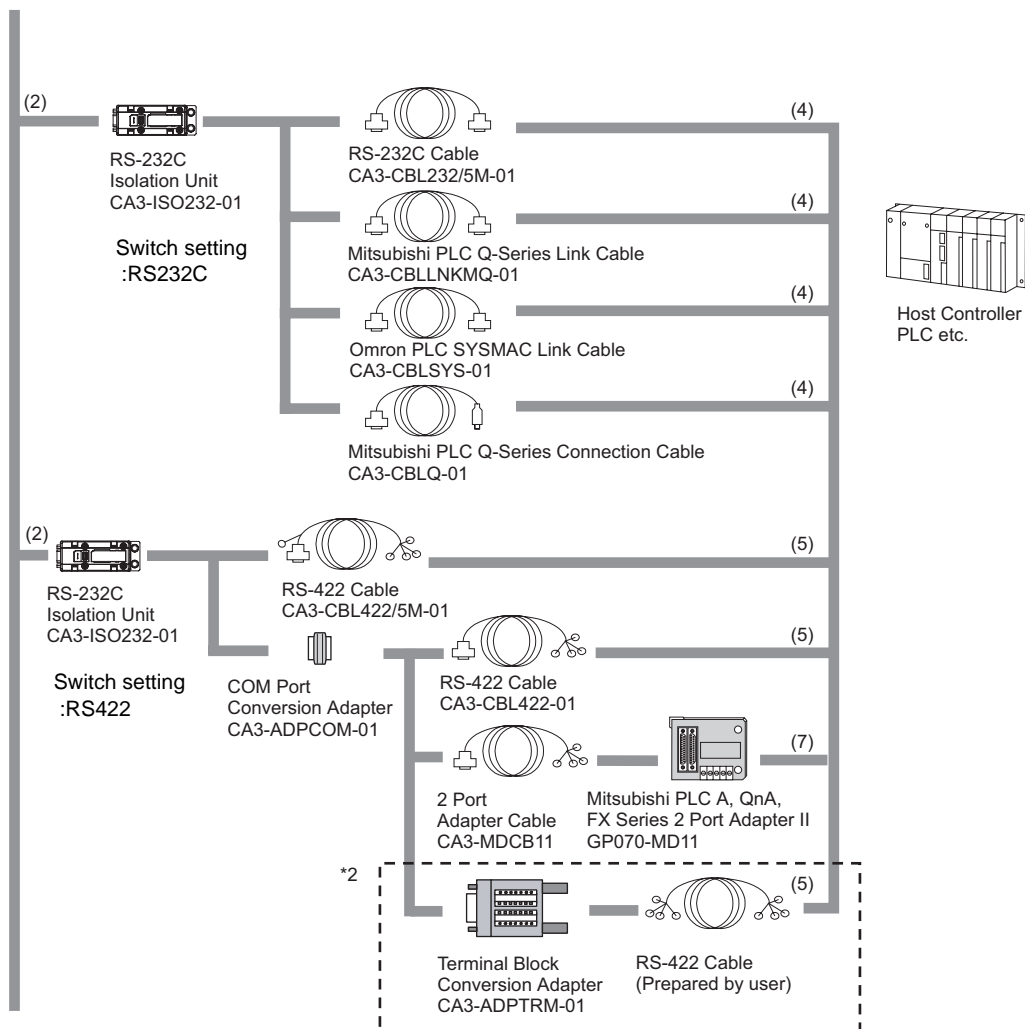
**NOTE**

- When connecting the CA3-ISO232-01, the 9 Pin's setting of COM port is required to be VCC. COM port settings can be set with the GP-Pro EX or in GP's offline mode.

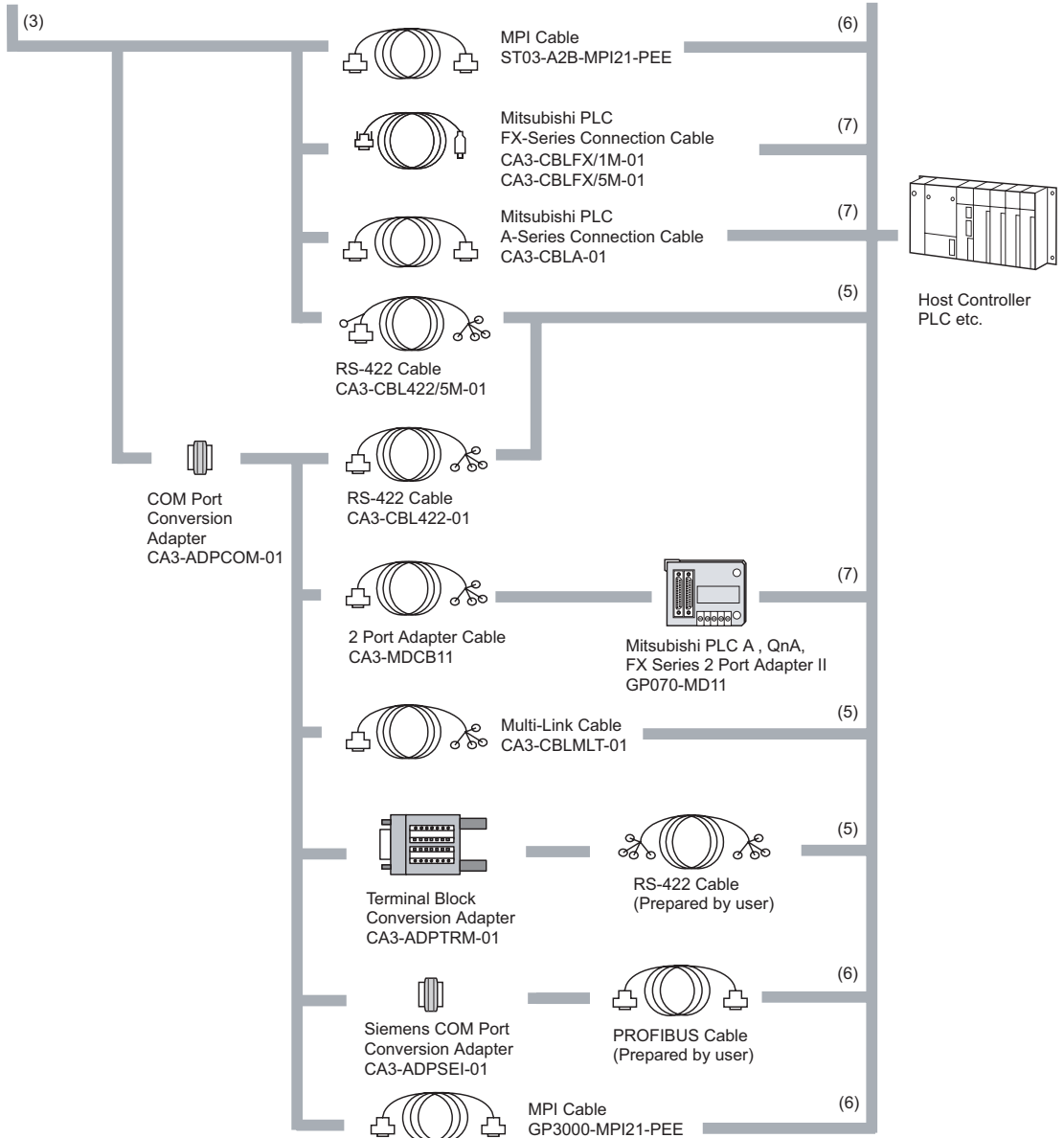

GP Interfaces	PLC Interfaces
(1) USB I/F	(4) RS-232C Port
(2) Serial Interface (COM1)	(5) RS-422 Port
(3) Serial Interface (COM2)	(6) RS-485 Port
(8) Expansion Unit Interface Not available with GP-3200 series	(7) Programing Console Port

◆Edit Mode Peripherals

GP Unit

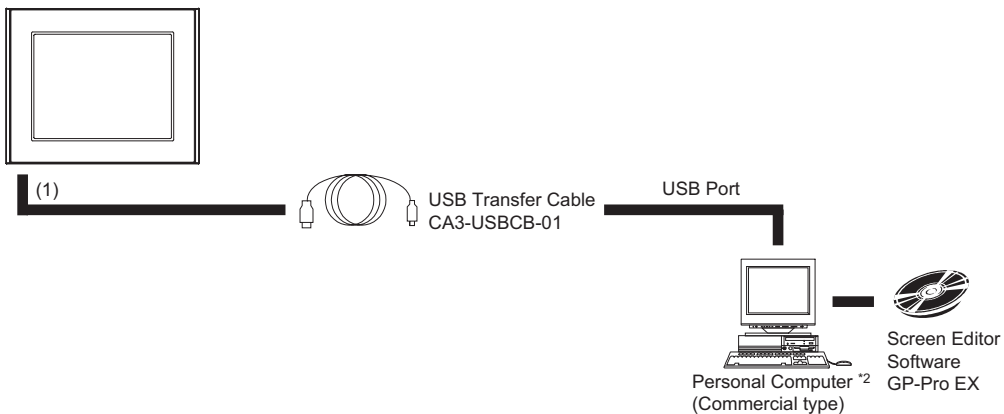

GP Interfaces

(1) USB Host Interface

*1 For supported models, refer to Pro-face's support site "Otasuke Pro!" (<http://www.pro-face.com/otasuke/>).

You can connect to this site by clicking the GP-Pro EX's [Help(H)] menu-[Connect to Support Site

"Otasuke Pro!" (o)] command.

*2 Certain types and models of PCs cannot be used.

SEE → *GP-Pro EX Reference Manual*

1.3 DIO Board Type

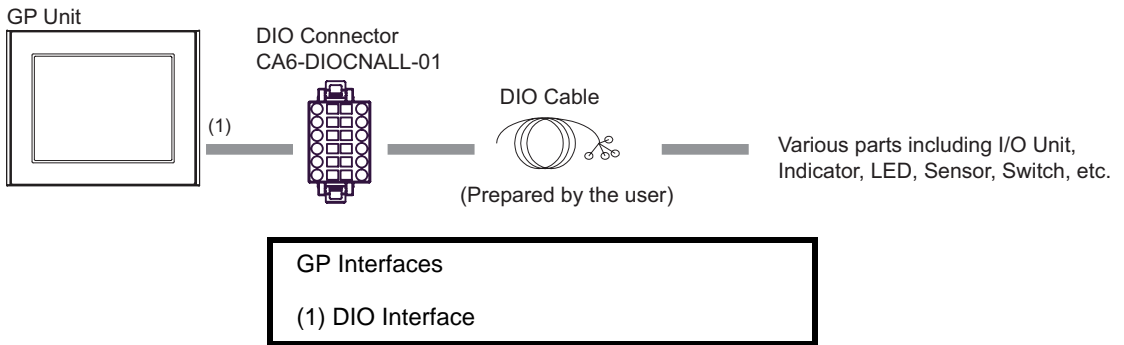

1.4 FLEX NETWORK Board Type

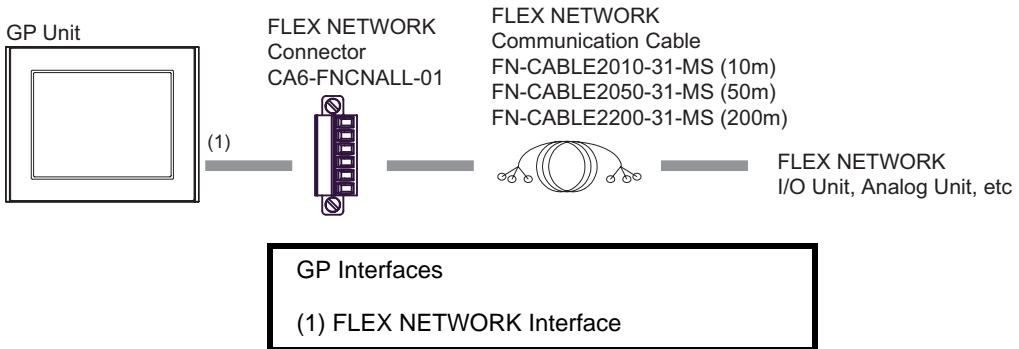

2 | Accessories

1. Accessories
2. Optional Item for the DIO Board Type
3. Optional Items for the FLEX NETWORK Board Type

This chapter describes peripheral devices that can be connected to GP Series units.

2.1 Accessories

All accessories listed here are produced by Digital Electronics Corporation.

2.1.1 Serial Interface Item

Product Name	Model No.	Description
RS-232C Cable	CA3-CBL232/5M-01 (5m)	Connects Mitsubishi PLC A-Series (or other host controller) to the AGP. (RS-232C)
RS-422 Cable	CA3-CBL422/5M-01 (5m)	Connects a host controller to the GP. (RS-422)
Mitsubishi PLC Q-Series Link Cable	CA3-CBLLNKM-01 (5m)	Connects Mitsubishi PLC Q-Series (or other host controller) to the AGP. (RS-232C)
Omron PLC SYSMAC Link Cable	CA3-CBLSYS-01 (5m)	Connects Omron PLC SYSMAC Series unit (or other host controller) to the AGP. (RS-232C)
Mitsubishi PLC A-Series Connection Cable	CA3-CBLA-01 (5m)	Connects Mitsubishi PLC A, QnA Series programming console I/F to AGP. (Simultaneous use of programming console is not possible.)
Mitsubishi PLC Q-Series Connection Cable	CA3-CBLQ-01 (5m)	Connects Mitsubishi PLC Q-Series programming console I/F to AGP. (Simultaneous use of programming console is not possible.)
Mitsubishi PLC FX-Series Connection Cable	CA3-CBLFX/1M-01 (1m) CA3-CBLFX/5M-01 (5m)	Connects Mitsubishi PLC FX-Series programming console I/F and AGP. (Simultaneous use of programming console is not possible.)
9-pin-to-25-pin RS-a232C Conversion Cable	CA3-CBLCBT232-01 (0.2m)	Connects a standard RS-232C cable (GP Connector,D-sub 25-pin) to the GP.
9-pin-to-25-pin RS-422 Conversion Cable	CA3-CBLCBT422-01 (0.2m)	Connects a standard RS-422 cable (GP Connector,D-sub 25-pin) to the GP.
RS-422 Cable	CA3-CBL422-01 (5m)	Connects a host controller to the GP. (RS-422)
2 Port Adapter Cable	CA3-MDCB11 (5m)	Connects Mitsubishi PLC to the GP using 2 port adapter II (RS-422).
Mitsubishi PLC A, QnA, FX Series 2 Port Adapter II	GP070-MD11	Allows simultaneous use of an GP Series unit and a Mitsubishi PLC A, QnA, FX Series peripheral device.
Multi-Link Cable	CA3-CBLMLT-01 (5m)	Connects a host controller to the GP for multi-link (n:1) communication.
Terminal Block Conversion Adapter	CA3-ADPTRM-01	Connects output from a serial interface with an RS-422 terminal block.
COM Port Conversion Adapter	CA3-ADPCOM-01	Connects optional RS-422 communication items to AGP unit's COM1 port.
On-line adapter	CA4-ADPONL-01	Terminal adapter in the case of performing RS-422/RS-485 communication at COM2 port.

Siemens COM Port Conversion Adapter	CA3-ADPSEI-01	Connects Siemens PLCs to the AGP. (for RS-485 communication)
MPI Cable	ST03-A2B-MPI21-PFE (3.5m) GP3000-MPI21-PFE (3.5m)	Connects a host controller to the GP for MPI communication.
RS-232C Isolation Unit	CA3-ISO232-01	Connects a host controller to the GP with provides isolation.(RS-232C and RS-422 are switchable.)
RS-485 Isolation Unit	CA3-ISO485-01	Connects a host controller to the GP with provides isolation.(RS-422 and RS-485 are switchable.)

2.1.2 USB Host Interface

Product Name	Model No.	Description
USB Transfer Cable	CA3-USBCB-01 (2m)	Downloads project data created with the Screen Editor via the GP unit's USB I/F.
USB Cable	FP-US00 (5m)	Connects a USB printer. (TYPE-B)
USB Front Cable	CA5-USBEXT-01 (1m)	Extension cable attaching USB port to front panel.
USB-Serial (RS-232C) Conversion Cable	CA6-USB232-01(0.5m)	The conversion cable for using a GP's USB I/F as the Serial (RS-232C) I/F. Connects a Modem only for the RS-232C communication method.*1

*1 For supported models, refer to Pro-face's support site "Otasuke Pro!" (<http://www.pro-face.com/otasuke/>).

You can connect to this site by clicking the GP-Pro EX's [Help(H)] menu-[Connect to Support Site "Otasuke Pro!" (o)] command.

2.1.3 CF Card Items

(GP-3200 series and AGP-3302B are not available)

Product Name	Model No.	Description
CF Card (128MB)	CA3-CFCALL/128MB-01	Inserted into the GP unit's CF Card slot.
CF Card (256MB)	CA3-CFCALL/256MB-01	
CF Card (512MB)	CA3-CFCALL/512MB-01	
CF Card (1GB)	CA6-CFCALL/1GB-01	
CF Card Adapter	GP077-CFAD10	Used for read/write of CF Card data via a PC's PCMCIA slot.

2.1.4 Option Items

Product Name	Model No.	Corresponding GP	Description
Screen Protection Sheet	CA6-DFS4-01	GP-3200 Series	Disposable, dirt-resistant sheet for the GP unit's screen. (5 sheets/set) (Hard type)
	CA3-DFS6-01	GP-3300 Series	
	PS400-DF00	GP-3400 Series	
	CA5-DFS10-01	AGP-35*0T	
	CA3-DFS12-01	AGP-3500L AGP-3500S GP-3600 Series	
	CA3-DFS15-01	GP-3700 Series	

2.1.5 Maintenance Items

Product Name	Model No.	Corresponding GP	Description
Installation Fastener	CA3-ATFALL-01	GP3000 Series	Used to install the GP into a solid panel.
Installation Gasket	ST400-WP01	GP-3200 Series	Provides dust and moisture resistance when GP is installed into a solid panel.
	CA3-WPG6-01	GP-3300 Series	
	CA5-WPG8-01	GP-3400 Series	
	CA5-WPG10-01	AGP-35*0T	
	CA3-WPG12-01	AGP-3500L AGP-3500S GP-3600 Series	
	CA3-WPG15-01	GP-3700 Series	
Replacement Backlight	CA5-BLU10T-01	AGP-35*0T*1	This backlight is used for replacement.
	CA6-BLU10T-02		
	PS501S-BU00	AGP-3500S	
	CA3-BLU12-01	AGP-3600T AGP-3650T	
	CA3-BLU15-01	GP-3700 Series	
Connector Cover	CA3-BUSCVR-01	GP3000 Series (except GP-3200 series)	Protects the AGP unit's rear face connector.
AUX Connector	CA5-AUXCNALL-01	GP-3400 Series GP-3500 Series GP-3600 Series GP-3700 Series	AUX connector for GP3000 series required in case an external output is used.
USB Cable Clamp (1 port)	CA5-USBATM-01	GP-3300 Series	USB Cable clamp for 1 port products to prevent disconnection.
USB Cable Clamp (2 port)	CA5-USBATL-01	GP-3200 Series GP-3400 Series GP-3500 Series GP-3600 Series GP-3700 Series	USB Cable clamp for 2 port products to prevent disconnection.
DC Power Supply Connector for Medium-sized Units	CA5-DCCNM-01	GP-3200 Series GP-3300 Series GP-3400 Series	Connector for attaching power supply to medium-sized units.

DC Power Supply Connector for Large-sized Units	CA5-DCCNL-01	GP-3500 Series GP-3600 Series GP-3700 Series	Connector for attaching power supply to large-sized units.
Panel Cutout Adapter	CA4-ATM5-01	GP-3300 Series	Panel cutout adapter for mounting GP-3300 series in cutout of GP-37W2B.
	CA4-ATM10-01	AGP-35*0T	Panel cutout dapper for mounting GP-3500 series (TFT color LCD type only) in cutout of GP-2500/2600 series.

*1 The corresponding backlight unit depends on your GP's revision. For details, please refer to "8.4.1 AGP-35*0T (page8-6)".

2.1.6 Expansion Unit

Product Name	Model No.	Corresponding GP	Description
VM UNIT (for VM-BS)	GP2000-VM41	AGP-35*0T AGP-36*0T	VM UNIT is a unit for capture of the video image.
PROFIBUS Slave Unit	CA5-PFSALL/ EX-01	GP3000 series (except GP-3200 series)	Expansion Unit for connecting GP to PROFIBUS network or communicating with a PROFIBUS-DP master.
Device Net Slave Unit	CA6-DNSALL/ EX-01	GP3000 series (except GP-3200 series)	Expansion Unit for connecting GP to DeviceNet network or communicating with a DeviceNet master.

2.2 Optional Item for the DIO Board Type

2.2.1 Maintenance Items

Product Name	Model No.	Description
DIO Connector	CA6-DIOCNALL-01	Connector attached to the DIO interface. Connects an external I/O device. (Set of 5 connectors)

2.3 Optional Items for the FLEX NETWORK Board Type

2.3.1 I/O Units

Product Name	Model No.	Description
FLEX NETWORK 16-Point Input Sink Source Type I/O Unit	FN-X16TS41	16-point sink/source shared I/O Unit. DC24V input signal can be connected.
FLEX NETWORK 32-Point Input Sink Source Type I/O Unit	FN-X32TS41	32-point sink-source shared I/O Unit. DC24V input signal can be connected.
FLEX NETWORK 16-Point Output Sink Type I/O Unit	FN-Y16SK41	16-point output sink I/O Unit.
FLEX NETWORK 16-Point Output Source Type I/O Unit	FN-Y16SC41	16-point output source I/O Unit.
FLEX NETWORK 8-Point Input Sink Source / 8-Point Transistor Output Sink Type I/O Unit	FN-XY08TS41	8-point input sink-source and 8-point transistor output sink mixed I/O unit. Both DC24V input signals and DC24V output (load current: 200mA max./) devices can be connected.
FLEX NETWORK 16-Point Input Sink Source / 16-Point Transistor Output Sink Type I/O Unit	FN-XY16SK41	16-point input sink-source and 16-point transistor output sink mixed I/O unit. Both DC24V input signals and DC24V output (load current: 200mA max./1.6A/common) devices can be connected.
FLEX NETWORK 16-Point Input Sink Source/16-Point Transistor Output Source Type I/O Unit	FN-XY16SC41	16-point input sink-source and 16-point transistor output source mixed I/O unit. Both DC24V input signals and DC24V output (load current: 200mA max./1.6A/common) devices can be connected.
FLEX NETWORK 32-Point Input Sink Source / 32-Point Transistor Output Sink Type I/O Unit	FN-XY32SKS41	32-point input sink-source and 32-point transistor output sink mixed I/O unit. Both DC24V input signals and DC24V output (load current: 200mA max./1.6A/common) devices can be connected.
FLEX NETWORK 8-Point Relay Output / 1 Common Type I/O Unit	FN-Y08RL41	8-point relay output (1 common) I/O Unit. Up to AC240V (1A) load current can be connected.

2.3.2 Analog Units

Product Name	Model No.	Description
FLEX NETWORK 2-Channel Analog/Digital Conversion Input Unit	FN-AD02AH41	Converts 2-channel analog signals to digital signals at 12-bit resolution.
FLEX NETWORK 2-Channel Digital/Analog Conversion Output Unit	FN-DA02AH41	Converts 2-channel 12-bit digital signal to analog signal and sends output.
FLEX NETWORK 4-Channel Analog/Digital Conversion Input Unit	FN-AD04AH11	Converts 4-channel analog signals to digital signals at 12-bit resolution.
FLEX NETWORK 4-Channel Digital/Analog Conversion Output Unit	FN-DA04AH11	Converts 4-channel 12-bit digital signal to analog signal and sends output.

2.3.3 Single-Axis Positioning Units

Product Name	Model No.	Description
FLEX NETWORK Single-Axis Positioning Unit	FN-PC10SK41	Both of this unit and GP can store positioning data. Motor driver connection cable (FN-PC10CB01) is required.
Teaching Loader for Single-Axis Positioning Unit	FN-PC10LD41	Programmer for Single-Axis Positioning Unit. Allows entry, editing and operation checking of high-precision positioning data. (5m cable included)

2.3.4 High-Speed Counter Unit

Product Name	Model No.	Description
FLEX NETWORK High Speed Counter Unit	FN-HC10SK41	High performance High-Speed counter that can easily change counter input types. Can create both a wide range of data and cam output.

2.3.5 Optional Items

Product Name	Model No.	Description
FLEX NETWORK Communication Cable	FN-CABLE2010-31-MS (10m)	Connect GP units with FLEX NETWORK units.
	FN-CABLE2050-31-MS (50m)	
	FN-CABLE2200-31-MS (200m)	
Motor Driver Connection Cable	FN-PC10CB01 (1m)	Connects the FLEX NETWORK single-axis positioning unit and the servo and stepping drivers.

2.3.6 Maintenance Items

Product Name	Model No.	Description
FLEX NETWORK Connector	CA6-FNCNALL-01	Connector attached to the FLEX NETWORK interface. Connects the FLEX NETWORK communication cable. (Set of 5 connectors)
Single-Axis Teaching Loader Cable	FN-LD10CBL (5m)	Connects the FLEX NETWORK single-axis positioning unit and the single-axis teaching loader.

3



Part Names and Functions

1. GP-3200 Series
2. GP-3300 Series
3. GP-3400 Series
4. GP-3500 Series
5. GP-3600 Series
6. GP-3700 Series

This chapter describes the GP's part name and functions of each part.

3.1 GP-3200 Series

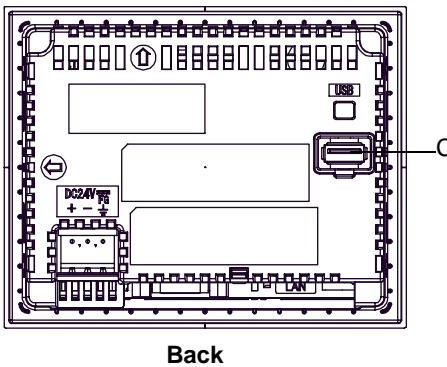
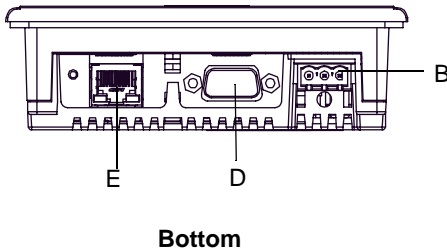
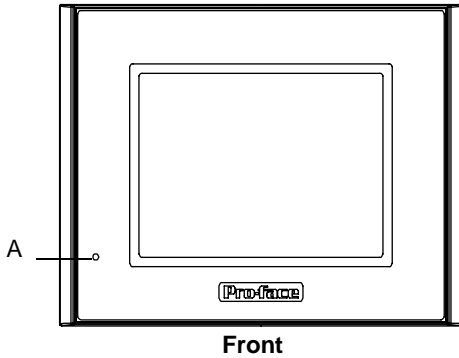

A: Status LED

This LED indicates the GP's status, e.g. power input, firmware RUN status or backlight condition. Also, indicates the status of logic program execution.

LED	Indicates
Green ON	Normal operation (power is ON.) or OFFLINE operation.
Orange Flashing	During software startup
Red ON	When power is turned on.
OFF	No Energization

B: Power Plug Connector

C: USB Host Interface

Complies with USB 1.1. Uses a "TYPE-A" connector. Power supply voltage: 5VDC±5%, Output current: 500mA(max). The maximum communication distance : 5m.

D: Serial Interface (COM1)

RS232C/RS422/RS485 serial interface. D-sub 9-pin plug type connector. Communication method is switched via software.

E: Ethernet Interface

(10BASE-T/100BASE-TX)

The Ethernet transmission interface (10BASE-T/100BASE-TX).

An RJ-45 type modular jack connector (8-pole) is used. The LED turns on or off to indicate the current status.

LED	Indicates
Green ON	Data transmission available
Green Flashing	Data transmission is occurring.
Green OFF	No connection or subsequent transmission failure
Yellow ON	During connection with 100BASE-TX
Yellow OFF	During connection with 10BASE-T or No connection

3.2 GP-3300 Series

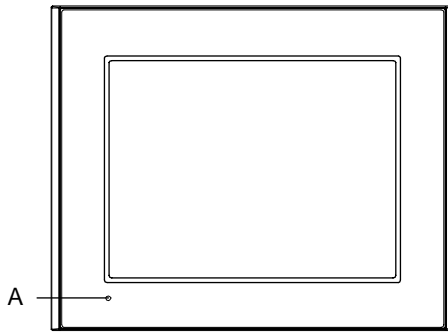

Front

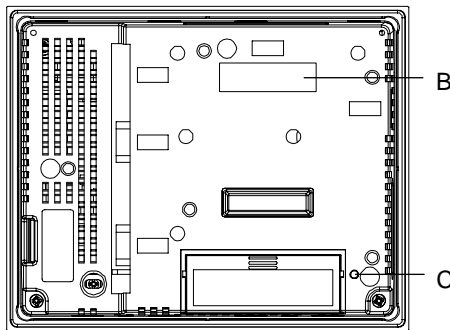

Back

A: Status LED

This LED indicates the GP's status, e.g. power input, firmware RUN status or backlight condition. Also, indicates the status of logic program execution. (The logic program is disabled in the AGP-3302B/3301L/3301S. The Status LED turns on only in Operation Mode (Drawing).)

Color	Indicator	Operation Mode (Drawing)	Logic execution mode (when logic is enabled)
Green	ON	OFFLINE	-
		In operation	RUN
	Flashing	In operation	STOP
Red	ON	When power is turned on.	
	Flashing	In operation	Major Error
Orange	ON	Backlight burnout	
	Flashing	During software startup	

B: Expansion Unit Interface

Connects expansion units with communication features.

C: CF Card Access Lamp

This lamp light up when CF card is inserted and CF card cover is closed. However, opening the CF card cover, in the CF card while accessing it continues to light up.

Access Lamp	Indicates
Green ON	The CF Card is inserted and the CF Card Cover is closed. Or, the CF Card is being accessed.
Green OFF	The CF Card is not inserted or is not being accessed.

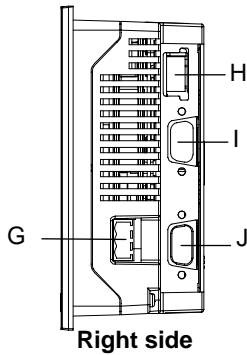
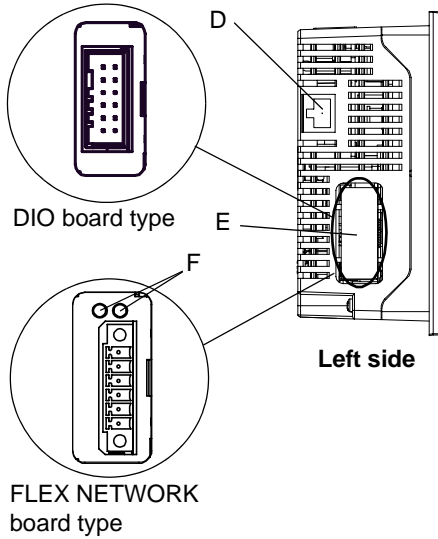

D: Ethernet Interface (10BASE-T/100BASE-TX)

The Ethernet transmission interface (10BASE-T/100BASE-TX). An RJ-45 type modular jack connector (8-pole) is used. The LED turns on or off to indicate the current status.

LED	Indicates
Green ON	Data transmission available
Green OFF	No connection or subsequent transmission failure
Yellow ON	Data transmission is occurring.
Yellow OFF	No data transmission

E: DIO Interface (DIO board type only) FLEX NETWORK Interface (FLEX NETWORK board type only)

The interface to which the unit with communication capabilities is connected.

F: FLEX NETWORK Communication Status LED

The LED indicates the status of FLEX NETWORK communication. The LED turns on to indicate the current status.

Status LED	Indicates
RUN (Green)	Turns on when Communication is enabled.
ERR (Red)	Turns on when failure occurs in connected I/O Unit.

G: Power Plug Connector

H: USB Host Interface

Complies with USB 1.1. Uses a “TYPE-A” connector. Power supply voltage: 5VDC±5%, Output current: 500mA(max). The maximum communication distance : 5m.

I: Serial Interface (COM1)

AGP-3300*/3301*:
RS232C/RS422/RS485 serial interface. D-sub 9-pin plug type connector. Communication method is switched via software.
AGP-3302*:
RS232C serial interface. D-sub 9-pin plug type connector.

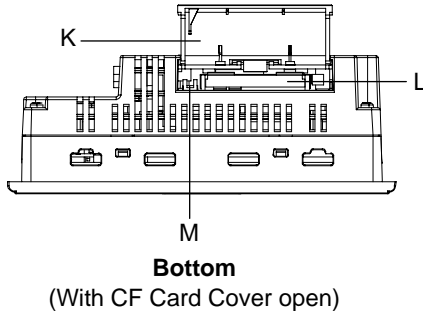
**J: Serial Interface (COM2)**

AGP-3300*/3301*:

RS422/RS485 serial interface. D-sub 9-pin socket type connector.

AGP-3302*:

RS422 serial interface. D-sub 9-pin plug type connector.

K: CF Card Cover

The CF Card I/F and Dip Switches are located in the CF Card Cover open. This cover must be closed when accessing the CF Card.

L: CF Card Interface

Insert the CF Card in this slot.

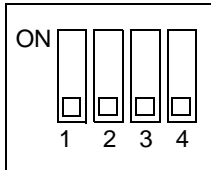
M: Dip Switches

Dip Switches	Function	ON	OFF	Note
1	CF Card Startup Settings (Controls unit startup from the CF Card.)	Startup from CF Card is enabled.	Startup from CF Card is disabled.	CF Card with startup data required.
2*1	Forced Transfer Mode	Forced Transfer Mode: ON	Forced Transfer Mode: OFF	-
3	Booking	-	-	Constantly OFF
4	This setting controls the forced closing of the CF Card cover.	Forced close enabled.	Forced close disabled.	Used when CF Card cover is damaged.

*1 When power supply is turned ON at dip switch 2 is ON, it starts with Transfer Mode.
Usually, use it in OFF.

3.3 GP-3400 Series

The following images of an GP-3450T Series unit.

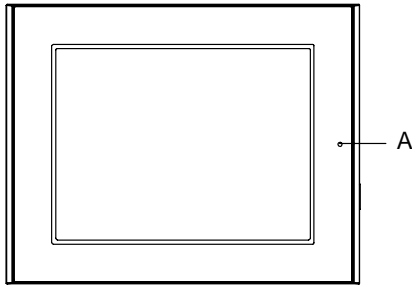

Front

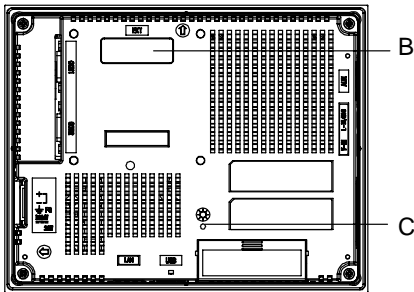

Back

A: Status LED

This LED indicates the GP's status, e.g. power input, firmware RUN status or backlight condition. Also, indicates the status of logic program execution.

Color	Indicator	Operation Mode (Drawing)	Logic execution mode (when logic is enabled)
Green	ON	OFFLINE	-
		In operation	RUN
	Flashing	In operation	STOP
Red	ON	When power is turned on.	
	Flashing	In operation	Major Error
Orange	ON	Backlight burnout	
	Flashing	During software startup	

B: Expansion Unit Interface

Connects expansion units with communication features.

C: CF Card Access Lamp

This lamp light up when CF card is inserted and CF card cover is closed. However, opening the CF card cover, in the CF card while accessing it continues to light up.

Access Lamp	Indicates
Green ON	The CF Card is inserted and the CF Card Cover is closed. Or, the CF Card is being accessed.
Green OFF	The CF Card is not inserted or is not being accessed.

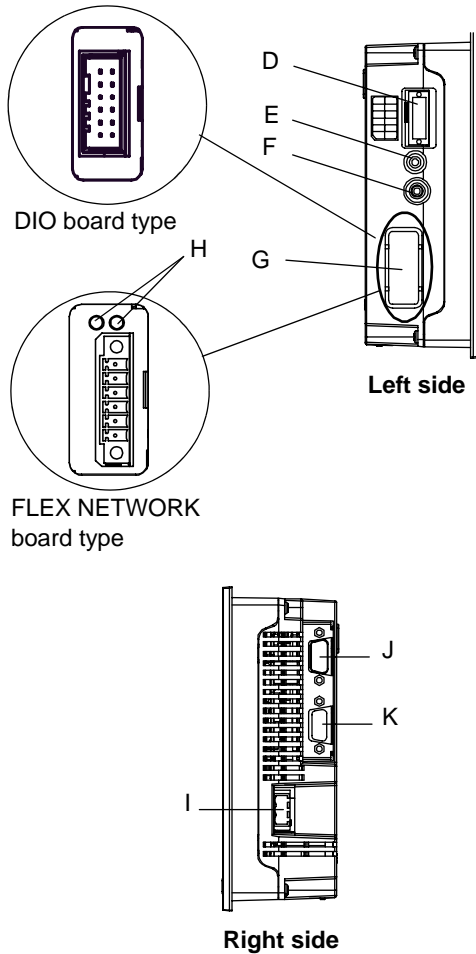

D: Auxiliary input/output /Voice Output Interface (AUX)

This interface is External Reset, Alarm Output, Buzzer Output, and sound output.

E: Audio Input Interface (L-IN/MIC) (AGP-3450T only)

This interface is connects a microphone. Use for mini jack connector ($\Phi 3.5\text{mm}$).

F: Video Input Interface (V-IN) (AGP-3450T only)

This interface is connects a video camera. NTSC (59.9Hz) / PAL (50Hz) system correspondence. Use for RCA Connector (75Ω).

G: DIO Interface (DIO board type only) FLEX NETWORK Interface (FLEX NETWORK board type only)

The interface to which the unit with communication capabilities is connected.

H: FLEX NETWORK Communication Status LED

The LED indicates the status of FLEX NETWORK communication. The LED turns on to indicate the current status.

Status LED	Indicates
RUN (Green)	Turns on when Communication is enabled.
ERR (Red)	Turns on when failure occurs in connected I/O Unit.

I: Power Plug Connector

J: Serial Interface (COM1)

RS232C/RS422/RS485 serial interface. D-sub 9-pin plug type connector. Communication method is switched via software.

K: Serial Interface (COM2)

RS422/RS485 serial interface. D-sub 9-pin socket type connector.

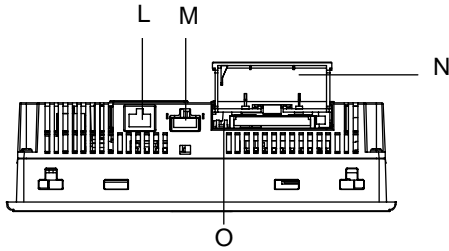

Bottom
(With CF Card Cover open)

L: Ethernet Interface (LAN)

The Ethernet transmission interface (10BASE-T/100BASE-TX). An RJ-45 type modular jack connector (8-pole) is used. The LED turns on or off to indicate the current status.

LED	Indicates
Green ON	Data transmission available
Green OFF	No connection or subsequent transmission failure
Yellow ON	Data transmission is occurring.
Yellow OFF	No data transmission

M: USB Host Interface (USB)

Complies with USB 1.1. Uses a “TYPE-A” connector. Power supply voltage: 5VDC±5%, Output current: 500mA(max). The maximum communication distance : 5m.

N: CF Card Cover

The CF Card I/F and Dip Switches are located in the CF Card Cover open. This cover must be closed when accessing the CF Card.

O: Dip Switches

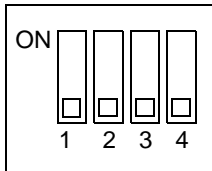

Dip Switches	Function	ON	OFF	Note
1	CF Card Startup Settings (Controls unit startup from the CF Card.)	Startup from CF Card is enabled.	Startup from CF Card is disabled.	CF Card with startup data required.
2*1	Forced Transfer Mode	Forced Transfer Mode: ON	Forced Transfer Mode: OFF	-
3	Booking	-	-	Constantly OFF
4	This setting controls the forced closing of the CF Card cover.	Forced close enabled.	Forced close disabled.	Used when CF Card cover is damaged.

*1 When power supply is turned ON at dip switch 2 is ON, it starts with Transfer Mode. Usually, use it in OFF.

3.4 GP-3500 Series

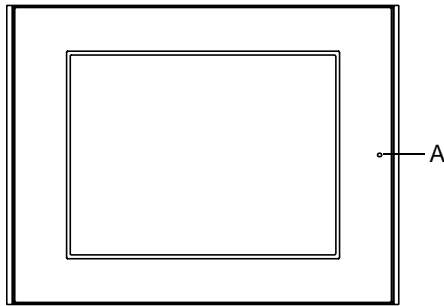

Front

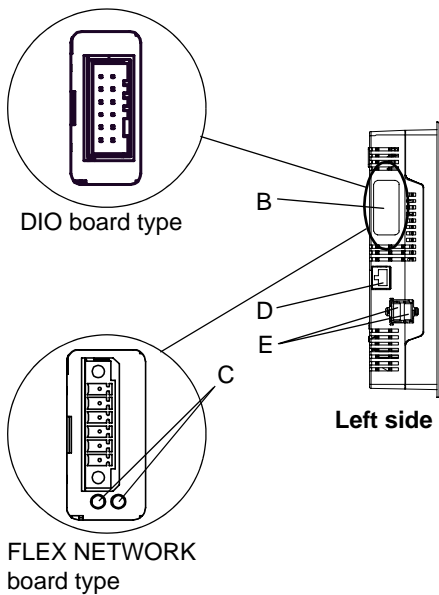

Left side

A: Status LED

This LED indicates the GP's status, e.g. power input, firmware RUN status or backlight condition. Also, indicates the status of logic program execution.

Color	Indicator	Operation Mode (Drawing)	Logic execution mode (when logic is enabled)
Green	ON	OFFLINE	-
	Flashing	In operation	RUN
Red	ON	In operation	STOP
	Flashing	When power is turned on.	Major Error
Orange	ON	Backlight burnout	
	Flashing	During software startup	

B: DIO Interface (DIO board type only)

FLEX NETWORK Interface (FLEX NETWORK board type only)

The interface to which the unit with communication capabilities is connected.

C: FLEX NETWORK Communication Status LED

The LED indicates the status of FLEX NETWORK communication. The LED turns on to indicate the current status.

Status LED	Indicates
RUN (Green)	Turns on when Communication is enabled.
ERR (Red)	Turns on when failure occurs in connected I/O Unit.

D: Ethernet Interface (LAN)

The Ethernet transmission interface (10BASE-T/100BASE-TX). An RJ-45 type modular jack connector (8-pole) is used. The LED turns on or off to indicate the current status.

LED	Indicates
Green ON	Data transmission available
Green OFF	No connection or subsequent transmission failure
Yellow ON	Data transmission is occurring.
Yellow OFF	No data transmission

E: USB Host Interface (USB) (X2)

Complies with USB 1.1. Uses a “TYPE-A” connector. Power supply voltage: 5VDC±5%, Output current: 500mA(max). The maximum communication distance : 5m.

F: Expansion Unit Interface 1*1

Connects expansion units with communication features.

G: VM Unit Interface *1 (AGP-35*0T only)

The interface which connects the VM unit manufactured by Digital Electronics Corporation.

H: Auxiliary input/output /Voice Output Interface (AUX)

This interface is External Reset, Alarm Output, Buzzer Output, and sound output.

I: Expansion Memory Interface Cover

Remove the cover to add more memory.

J: CF Card Access LED

This lamp light up when CF card is inserted and CF card cover is closed. However, opening the CF card cover, in the CF card while accessing it continues to light up.

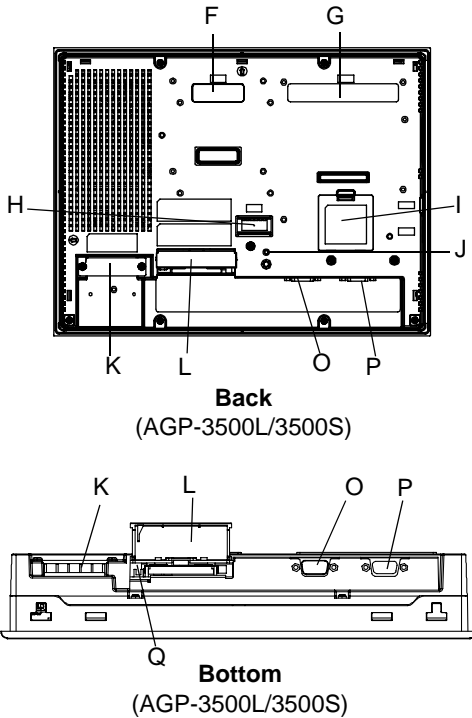

Access Lamp	Indicates
Green ON	The CF Card is inserted and the CF Card Cover is closed. Or, the CF Card is being accessed.
Green OFF	The CF Card is not inserted or is not being accessed.

*1 The Expansion Unit Interface 1 and VM Unit Interface cannot be used simultaneously with AGP-35*0T.

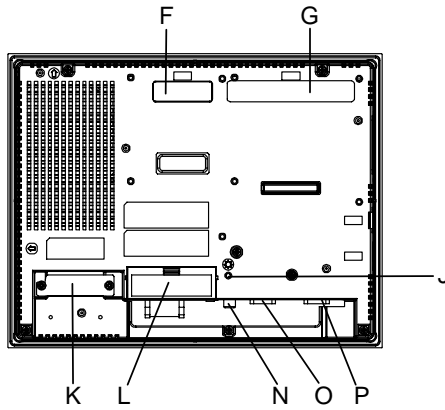

Back
(AGP-35*0T)

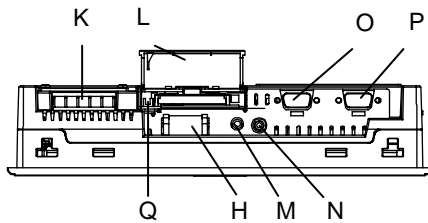

Bottom
(AGP-35*0T)

Q: Dip Switches1

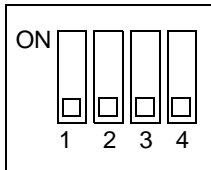

Dip Switches	Function	ON	OFF	Note
1	CF Card Startup Settings (Controls unit startup from the CF Card.)	Startup from CF Card is enabled.	Startup from CF Card is disabled.	CF Card with startup data required.
2*1	Forced Transfer Mode	Forced Transfer Mode: ON	Forced Transfer Mode: OFF	-
3	Booking	-	-	Constantly OFF
4	This setting controls the forced closing of the CF Card cover.	Forced close enabled.	Forced close disabled.	Used when CF Card cover is damaged.

*1 When power supply is turned ON at dip switch 2 is ON, it starts with Transfer Mode.

Usually, use it in OFF.

K: Power Input Terminal Block (AC model), Power Plug Connector (DC model)

L: CF Card Cover

The CF Card I/F and Dip Switches are located in the CF Card Cover open. This cover must be closed when accessing the CF Card.

M: Audio Input Interface (L-IN/MIC) (AGP-3550T/AGP-3560T only)

This interface is connects a microphone. Use for mini jack connector (Φ 3.5mm).

N: Video Input Interface (V-IN) (AGP-3550T/AGP-3560T only)

This interface is connects a video camera. NTSC (59.9Hz) / PAL (50Hz) system correspondence. Use for RCA Connector (75 Ω).

O: Serial Interface (COM1)

RS232C/RS422/RS485 serial interface. D-sub 9-pin plug type connector. Communication method is switched via software.

P: Serial Interface (COM2)

RS422 /RS485 serial interface. D-sub 9-pin socket type connector.

3.5 GP-3600 Series

The following images of an AGP- 3650T (AC model) unit.

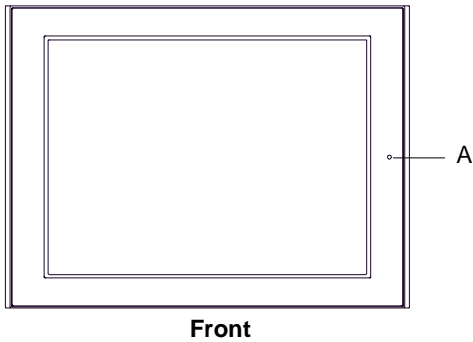

A: Status LED

This LED indicates the GP's status, e.g. power input, firmware RUN status or backlight condition. Also, indicates the status of logic program execution.

Color	Indicator	Operation Mode (Drawing)	Logic execution mode (when logic is enabled)
Green	ON	OFFLINE	-
	Flashing	In operation	STOP
Red	ON	When power is turned on.	
	Flashing	In operation	Major Error
Orange	ON	Backlight burnout	
	Flashing	During software startup	

B: DIO Interface (DIO board type only)

FLEX NETWORK Interface (FLEX NETWORK board type only)

The interface to which the unit with communication capabilities is connected.

C: FLEX NETWORK Communication Status LED

The LED indicates the status of FLEX NETWORK communication. The LED turns on to indicate the current status.

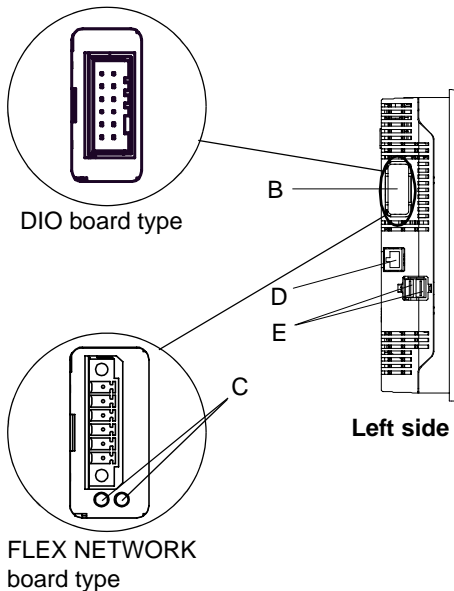

Status LED	Indicates
RUN (Green)	Turns on when Communication is enabled.
ERR (Red)	Turns on when failure occurs in connected I/O Unit.

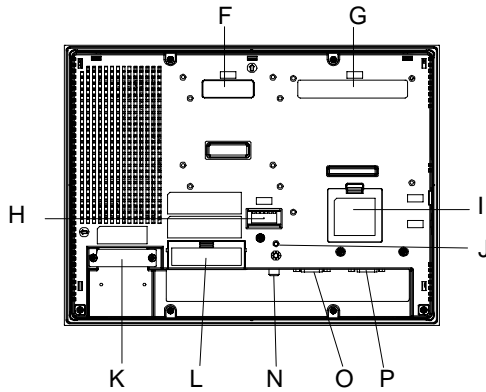

Back

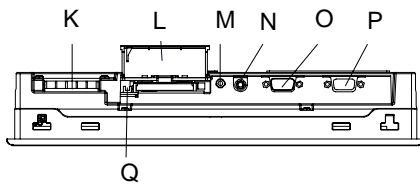

Bottom

D: Ethernet Interface (LAN)

The Ethernet transmission interface (10BASE-T/100BASE-TX). An RJ-45 type modular jack connector (8-pole) is used. The LED turns on or off to indicate the current status.

LED	Indicates
Green ON	Data transmission available
Green OFF	No connection or subsequent transmission failure
Yellow ON	Data transmission is occurring.
Yellow OFF	No data transmission

E: USB Host Interface (USB) (X2)

Complies with USB 1.1. Uses a "TYPE-A" connector. Power supply voltage: 5VDC \pm 5%, Output current: 500mA(max). The maximum communication distance : 5m.

F: Expansion Unit Interface 1

Connects expansion units with communication features.

G: VM Unit Interface

The interface which connects the VM unit manufactured by Digital Electronics Corporation.

H: Auxiliary input/output /Voice Output Interface (AUX)

This interface is External Reset, Alarm Output, Buzzer Output, and sound output.

I: Expansion Memory Interface Cover

Remove the cover to add more memory.

J: CF Card Access LED

This lamp light up when CF card is inserted and CF card cover is closed. However, opening the CF card cover, in the CF card while accessing it continues to light up.

Access Lamp	Indicates
Green ON	The CF Card is inserted and the CF Card Cover is closed. Or, the CF Card is being accessed.
Green OFF	The CF Card is not inserted or is not being accessed.

K: Power Input Terminal Block (AC model), Power Plug Connector (DC model)**L: CF Card Cover**

The CF Card I/F and Dip Switches are located in the CF Card Cover open. This cover must be closed when accessing the CF Card.

M: Audio Input Interface (L-IN/MIC) (AGP-3650T only)

This interface is connects a microphone. Use for mini jack connector (Φ 3.5mm).

N: Video Input Interface (V-IN) (AGP-3650T only)

This interface is connects a video camera. NTSC (59.9Hz) / PAL (50Hz) system correspondence. Use for RCA Connector (75Ω).

O: Serial Interface (COM1)

RS232C/RS422/RS485 serial interface. D-sub 9-pin plug type connector. Communication method is switched via software.

P: Serial Interface (COM2)

RS422/RS485 serial interface. D-sub 9-pin socket type connector.

Q: Dip Switches

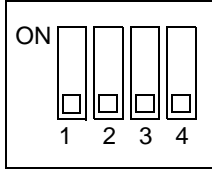

Dip Switches	Function	ON	OFF	Note
1	CF Card Startup Settings (Controls unit startup from the CF Card.)	Startup from CF Card is enabled.	Startup from CF Card is disabled.	CF Card with startup data required.
2*1	Forced Transfer Mode	Forced Transfer Mode: ON	Forced Transfer Mode: OFF	-
3	Booking	-	-	Constantly OFF
4	This setting controls the forced closing of the CF Card cover.	Forced close enabled.	Forced close disabled.	Used when CF Card cover is damaged.

*1 When power supply is turned ON at dip switch 2 is ON, it starts with Transfer Mode. Usually, use it in OFF.

3.6 GP-3700 Series

The following images of an AGP-3750 (AC model) unit.

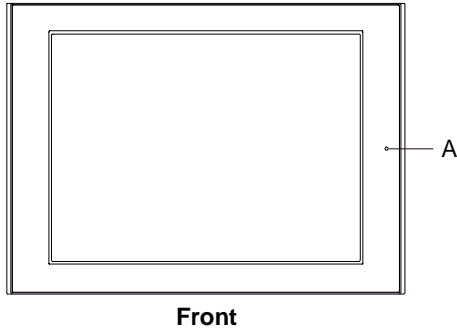

A: Status LED

This LED indicates the GP's status, e.g. power input, firmware RUN status or backlight condition. Also, indicates the status of logic program execution.

Color	Indicator	Operation Mode (Drawing)	Logic execution mode (when logic is enabled)
Green	ON	OFFLINE	-
	Flashing	In operation	STOP
Red	ON	When power is turned on.	
	Flashing	In operation	Major Error
Orange	ON	Backlight burnout	
	Flashing	During software startup	

B: Expansion Unit Interface (for internal)

Connects expansion units with communication features.

C: Ethernet Interface (LAN)

The Ethernet transmission interface (10BASE-T/100BASE-TX). An RJ-45 type modular jack connector (8-pole) is used. The LED turns on or off to indicate the current status.

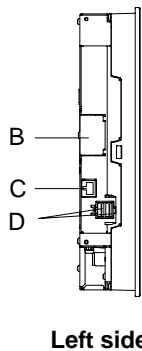

LED	Indicates
Green ON	Data transmission available
Green OFF	No connection or subsequent transmission failure
Yellow ON	Data transmission is occurring.
Yellow OFF	No data transmission

D: USB Host Interface (USB) (X2)

Complies with USB 1.1. Uses a "TYPE-A" connector. Power supply voltage: 5VDC \pm 5%, Output current: 500mA(max). The maximum communication distance : 5m.

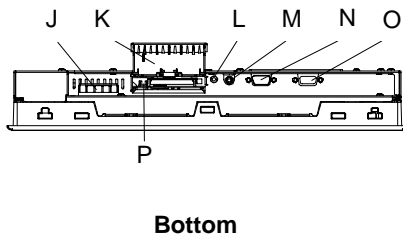
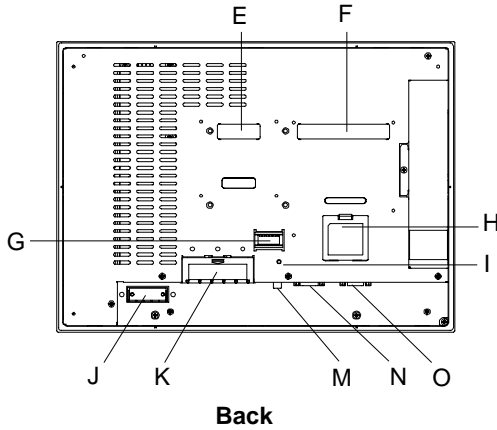

E: Expansion Unit Interface 1

Connects expansion units with communication features.

F: VM Unit Interface

The interface which connects the VM unit manufactured by Digital Electronics Corporation.

G: Auxiliary input/output /Voice Output Interface (AUX)

This interface is External Reset, Alarm Output, Buzzer Output, and sound output.

H: Expansion Memory Interface Cover

Remove the cover to add more memory.

I: CF Card Access LED

This lamp light up when CF card is inserted and CF card cover is closed. However, opening the CF card cover, in the CF card while accessing it continues to light up.

Access Lamp	Indicates
Green ON	The CF Card is inserted and the CF Card Cover is closed. Or, the CF Card is being accessed.
Green OFF	The CF Card is not inserted or is not being accessed.

J: Power Input Terminal Block (AC model), Power Plug Connector (DC model)

K: CF Card Cover

The CF Card I/F and Dip Switches are located in the CF Card Cover open. This cover must be closed when accessing the CF Card.

L: Audio Input Interface (L-IN/MIC)

This interface is connects a microphone. Use for mini jack connector (Φ3.5mm).

M: Video Input Interface (V-IN)

This interface is connects a video camera. NTSC (59.9Hz) / PAL (50Hz) system correspondence. Use for RCA Connector (75Ω).

N: Serial Interface (COM1)

RS232C/RS422/RS485 serial interface. D-sub 9-pin plug type connector. Communication method is switched via software.

O: Serial Interface (COM2)

RS422/RS485 serial interface. D-sub 9-pin socket type connector.

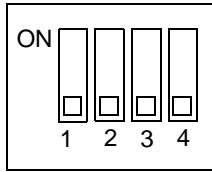
P: Dip Switches

Dip Switches	Function	ON	OFF	Note
1	CF Card Startup Settings (Controls unit startup from the CF Card.)	Startup from CF Card is enabled.	Startup from CF Card is disabled.	CF Card with startup data required.
2*1	Forced Transfer Mode	Forced Transfer Mode: ON	Forced Transfer Mode: OFF	-
3	Booking	-	-	Constantly OFF
4	This setting controls the forced closing of the CF Card cover.	Forced close enabled.	Forced close disabled.	Used when CF Card cover is damaged.

*1 When power supply is turned ON at dip switch 2 is ON, it starts with Transfer Mode. Usually, use it in OFF.

4

Specifications

1. GP-3200 Series
2. GP-3300 Series
3. GP-3400 Series
4. GP-3500 Series
5. GP-3600 Series
6. GP-3700 Series

This chapter describes the general, functional and interface specifications of the GP as well as its dimensions.

4.1 GP-3200 Series

4.1.1 General Specifications

■Electrical Specifications

Power Supply	Input Voltage	DC24V
	Rated Voltage	DC19.2 to 28.8V
	Allowable Voltage Drop	2ms (max.)
	Power Consumption	13W (max.)
	In-Rush Current	30A (max.)
Voltage Endurance		AC1000V 20mA for 1 minute (between charging and FG terminals)
Insulation Resistance		DC500V 10M Ω (min.) (between charging and FG terminals)

■Environmental Specifications

Physical	Surrounding Air Temperature	0 to +50°C*1
	Storage Temperature	-20 to +60°C
	Ambient Humidity	10 to 90% RH (Wet bulb temperature: 39°C max. - no condensation.)
	Storage Humidity	10 to 90% RH (Wet bulb temperature: 39°C max. - no condensation.)
	Dust	0.1mg/m ³ and below (non-conductive levels)
	Pollution Degree	For use in Pollution Degree 2 environment
	Atmosphere	Free of corrosive gases
	Air Pressure Vibration Resistance (availability altitude)	800 to 1114hPa (2,000 meters above sea-level and below)
Mechanical	Vibration Resistance	IEC61131-2 compliant 5 to 9Hz single-amplitude 3.5mm 9 to 150Hz constant-accelerated velocity 9.8m/s ² X,Y,Z directions for 10 cycle (100 minute)
	Concussion Resistance	IEC61131-2 compliant (147m/s ² X,Y,Z directions for 3 time)
Electrical	Noise Immunity	Noise Voltage: 1000V _{p-p} Pulse Duration: 1 μ s Rise Time: 1ns (via noise simulator)
	Electrostatic Discharge Immunity	6kV (complies with EN 61000-4-2 Level 3)

*1 In the case of AGP-3200A , Extended use in environments where Surrounding air temperature is 40°C or higher may degrade the display quality and result in decreased contrast.

■ Structural Specifications

Installation	Grounding	Grounding resistance of 100Ω 2mm ² or thicker wire, or your country's applicable standard. (Same for FG and SG terminals)
	Structure* ¹	Rating: Equivalent to IP65f NEMA #250 TYPE 4X/13 (Front surface at panel embedding) Feature size: All-in-one Installation configuration: Panel embedding
	Cooling Method	Natural air circulation
	Weight Approx.	0.4kg[0.9lb] max. (unit only)
	External Dimensions	W130.0mm[5.12in] X H104.0mm[4.09in] X D40.0mm[1.57in]
	Panel Cut Dimensions	W118.5mm[4.67in] X H92.5mm[3.64in]* ² Panel Thickness : 1.6mm[0.06in] to 5.0mm[0.20in]

*1 The front face of the GP unit, installed in a solid panel, has been tested using conditions equivalent to the standards shown in the specification. Even though the GP unit's level of resistance is equivalent to these standards, oils that should have no effect on the GP can possibly harm the unit. This can occur in areas where either vaporized oils are present, or where low viscosity cutting oils are allowed to adhere to the unit for long periods of time. If the GP's front face protection sheet becomes peeled off, these conditions can lead to the ingress of oil into the GP and separate protection measures are suggested.

Also, if non-approved oils are present, it may cause deformation or corrosion of the front panel's plastic cover. Therefore, prior to installing the GP be sure to confirm the type of conditions that will be present in the GP's operating environment.

If the installation gasket is used for a long period of time, or if the unit and its gasket are removed from the panel, the original level of the protection cannot be guaranteed. To maintain the original protection level, be sure to replace the installation gasket regularly.

*2 As for dimensional tolerance everything +1/-0mm[+0.04/-0in] and R in angle are below R3[R0.12in].

4.1.2 Performance Specifications

■ Performance Specifications

Application ^{*1}		FLASH EPROM 6MB
Data Backup		SRAM 320Kbyte
		Used lithium battery for backup memory
Interface	Serial Interface	COM1: RS232C/RS422/RS485 Asynchronous Transmission: Data Length: 7 bit/8 bit Parity: none, Odd or Even Stop Bit: 1bit/2bit Data transmission Speed: 2400bps to 115.2Kbps 187.5Kbps(MPI) Connector: DSUB-9pin plug
	Ethernet Interface	Ethernet(IEEE802.3u,10BASE-T/100BASE-TX) Connector: modular jack connector (RJ-45)
	USB Host Interface	Conforms to USB1.1.(TYPE-A conn.) x 1 Power Supply Voltage: DC5V ± 5% Output Current: 500mA(max.) Communication Distance:5m(max.)
Clock Accuracy ^{*2}		± 65 seconds/ month (at room temperature)

*1 It is user active capacity.

*2 The GP's internal clock has a slight error. At normal operating temperatures and conditions, with the GP operating from its lithium battery, the degree of error is 65 seconds per month. Variations in operating conditions and battery life can cause this error to vary from -380 to +90 seconds per month. For systems where this degree of error will be a problem, the user should be sure to monitor this error and make adjustments when required.

NOTE

- When the message “RAAA051 Low battery” is displayed, supply power to the display unit and fully charge the battery. The battery charges within 24 hours to a level which allows backup operation. Completing a full charge requires about 96 hours (4 days).
- A Lithium battery's lifetime is: 10 years when the battery's ambient temperature is 40°C or less. 4.1 years when the battery's ambient temperature is 50°C or less. 1.5 years when the battery's ambient temperature is 60°C or less.

When used for backup:

Approximately 100 days, with a fully charged battery.

Approximately 6 days, with a half-charged battery.

- 1:1 connections using a cross cable may not be possible depending on the type of personal computer and network card you are using.

Make sure to use a hub for the Ethernet Communication.

■ Display Specifications

		AGP-3200A	AGP-3200T
Display Type		Monochrome Amber/Red LCD	TFT Color LCD
Resolution		W320 X H240 pixels	
Dot pitch		W0.24mm[0.01in] X H0.24mm[0.01in]	
Effective Display Area		W78.8mm[3.10in] X H59.6mm[2.35in]	
Color/Shade level		Black and White (8 Shades)	256 Colors(No blink) 64 Colors(Enables blink feature)
Backlight		LED (Not user replaceable. When replacement is required, contact your local GP distributor.)	
Brightness control		16 levels of adjustment available via touch panel	
Contrast Adjustment		8 levels of adjustment available via touch panel	Not applicable
Display Service Life		MTBF value: 50, 000hrs. (TYP) (Backlight display service life is not included.)	MTBF value: 40, 000hrs. (TYP) (Backlight display service life is not included.)
Backlight Service Life		50,000hrs. or more (at 25°C and continuous operation - period until backlight brightness decreases to 50%)	40,000hrs. or more (at 25°C and continuous operation - period until backlight brightness decreases to 50%)
Language Fonts		Japanese: 6962 (JIS Standards 1 & 2)(including 607 non-kanji characters) ANK: 158 (Korean fonts, Simplified Chinese and Taiwanese traditional Chinese fonts are downloadable.	
Text composition	Character Sizes	Standard font: 8X8, 8X16, 16X16 and 32X32 dot fonts Stroke font: 6 to 127dot fonts	
	Font Sizes	Standard font: Width can be expanded up to 8 times. Height can be expanded up to 8 times ^{*1}	
Text	8 X 8 dots	40 Char. X 30 rows	
	8 X 16 dots	40 Char. X 15 rows	
	16 X 16 dots	20 Char. X 15 rows	
	32 X 32 dots	10 Char. X 7 rows	

*1 The other font sizes can be set up by software.

■ Touch Panel Specifications

Type	Resistive Film (analog)
Resolution	1024 X 1024
Service Life	1,000,000 times or more

4.1.3 Interface Specifications

This section describes the specifications of each interface of the GP Series unit.

- IMPORTANT**
- The GP unit's serial interface is not isolated. When the host (PLC) unit is also not isolated, be sure to connect the Pin #5 SG (Signal Ground) terminal to reduce the risk of damaging the RS232C/RS422/RS485 circuit.
 - When connecting an external device to the GP using the SG terminal, be sure to check that no short-circuit loop is created when you setup the system.

- NOTE**
- When isolation is necessary, you can use the RS232C isolation unit (CA3-ISO232-01) on COM1.

Serial Interfaces

Serial Interfaces (COM1)

This interface is used to connect an RS232C/RS422/RS485^{*1} cable. D-sub 9-pin plug connector is used.

<GP unit side>

GP Connector	XM2C-0942-502LX <OMRON Co.>
--------------	-----------------------------

<Cable side>

Recommended Cable Connector	XM2D-0901 <OMRON Co.>
Recommended Cable Cover	XM2S-0913 <OMRON Co.>
Recommended Jack Screw	XM2Z-0073 <OMRON Co.>
Interfit Bracket	#4-40 inch screws are used.

In the case of RS232C

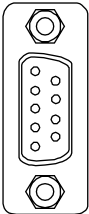
Pin Arrangement	Pin No.	RS232C		
		Signal Name	Direction	Meaning
 <p>(GP unit side)</p>	1	CD	Input	Carrier Detect
	2	RD(RXD)	Input	Receive Data
	3	SD(TXD)	Output	Send Data
	4	ER(DTR)	Output	Data Terminal Ready
	5	SG	-	Signal Ground
	6	DR(DSR)	Input	Data Set Ready
	7	RS(RTS)	Output	Request to Send
	8	CS(CTS)	Input	Send Possible
	9	CI(RI)/VCC	Input/-	Called status display +5V±5% Output 0.25A ^{*2}
	Shell	FG	-	Frame Ground (Common with SG)

*1 Communication method is switched via software.

*2 The RI/VCC selection for Pin #9 is switched via software. The VCC output is not protected against overcurrent. To prevent damage or a unit malfunction, use only the rated current.

In the case of RS422/RS485

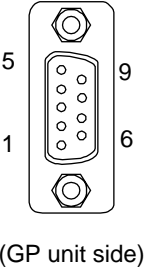
Pin Arrangement	Pin No.	RS422/RS485		
		Signal Name	Direction	Meaning
 <p>(GP unit side)</p>	1	RDA	Input	Receive Data A(+)
	2	RDB	Input	Receive Data B(-)
	3	SDA	Output	Send Data A(+)
	4	ERA	Output	Data Terminal Ready A(+)
	5	SG	-	Signal Ground
	6	CSB	Input	Send Possible B(-)
	7	SDB	Output	Send Data B(-)
	8	CSA	Input	Send Possible A(+)
	9	ERB	Output	Data Terminal Ready B(-)
	Shell	FG	-	Frame Ground (Common with SG)

4.1.4 Dimensions

The following dimensions apply to all GP-3200 Series units.

■ External Dimensions

Unit: mm[in.]

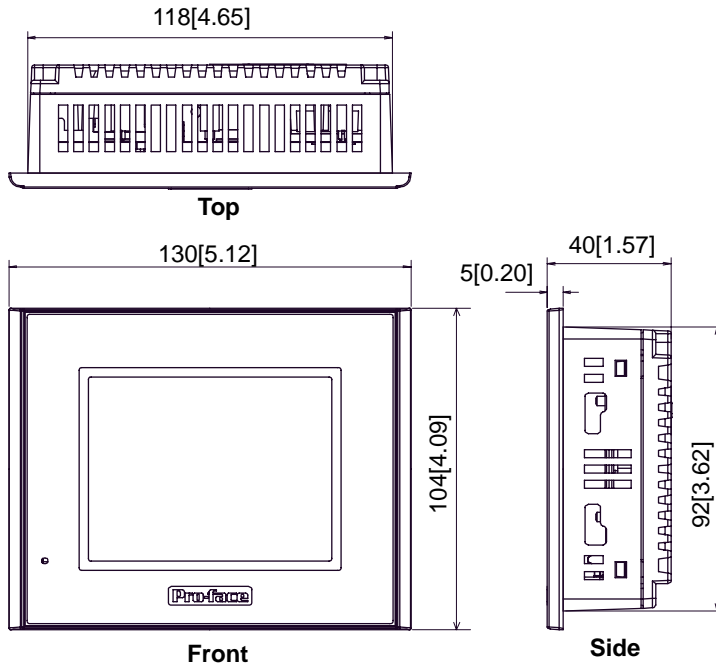

■ Installation Fasteners Attached Dimensions

Unit: mm[in.]

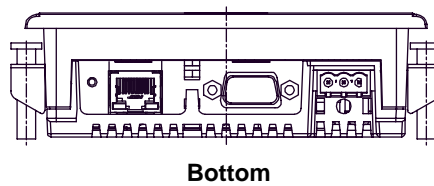
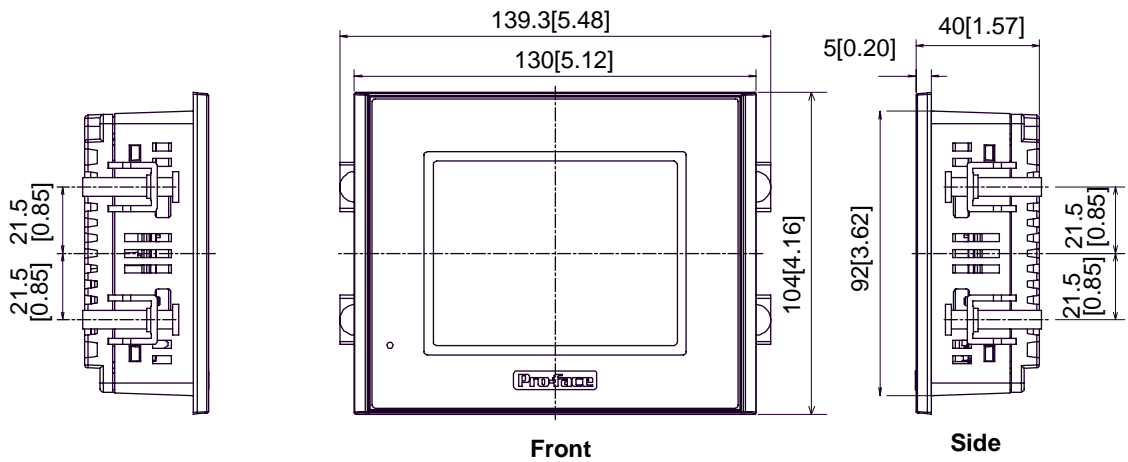
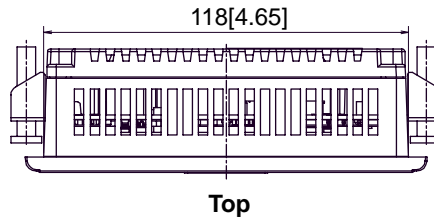

■ Cable Attached Dimensions

Unit: mm[in.]

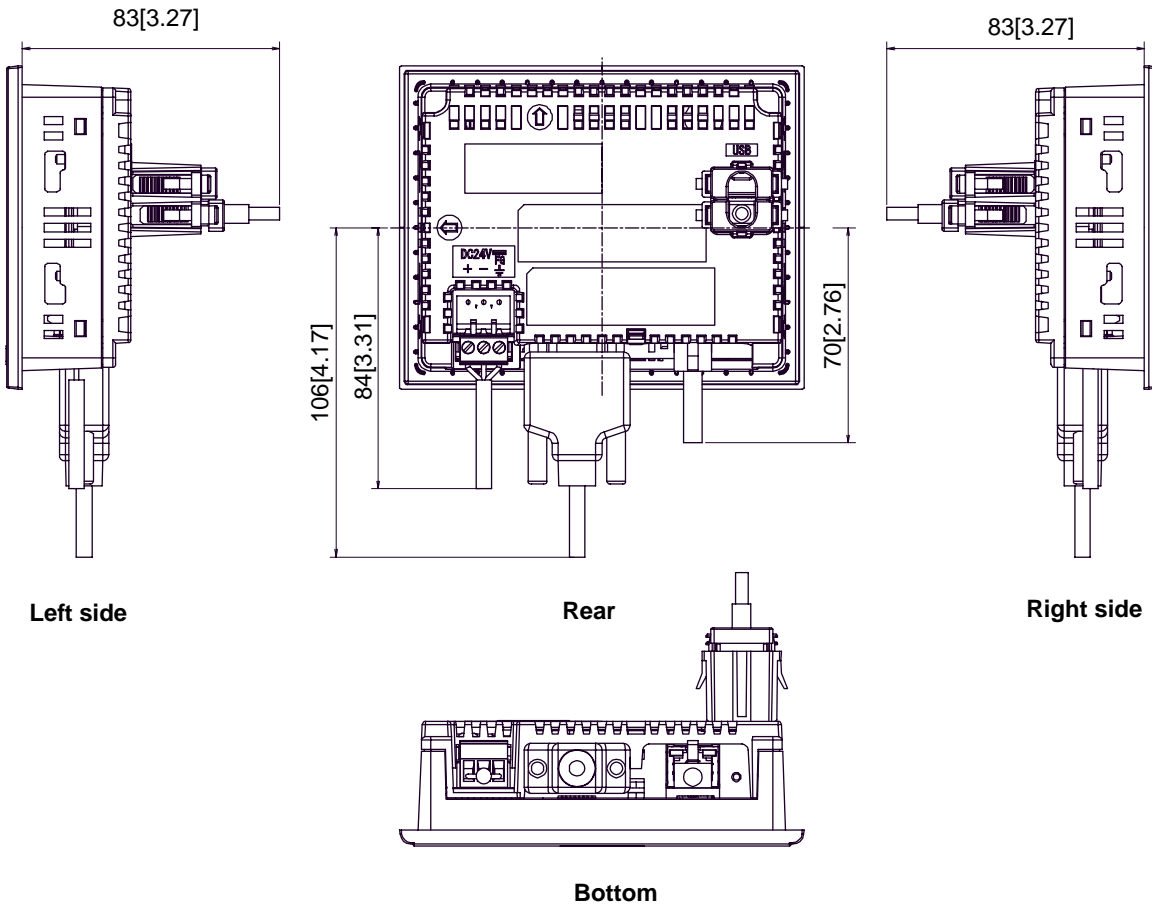

IMPORTANT

- All the above values are designed in case of cable bending. The dimensions given here are representative values depending on the type of connection cable used. Therefore, they are all intended for reference only.

■ Panel Cut Dimensions

Unit: mm[in.]

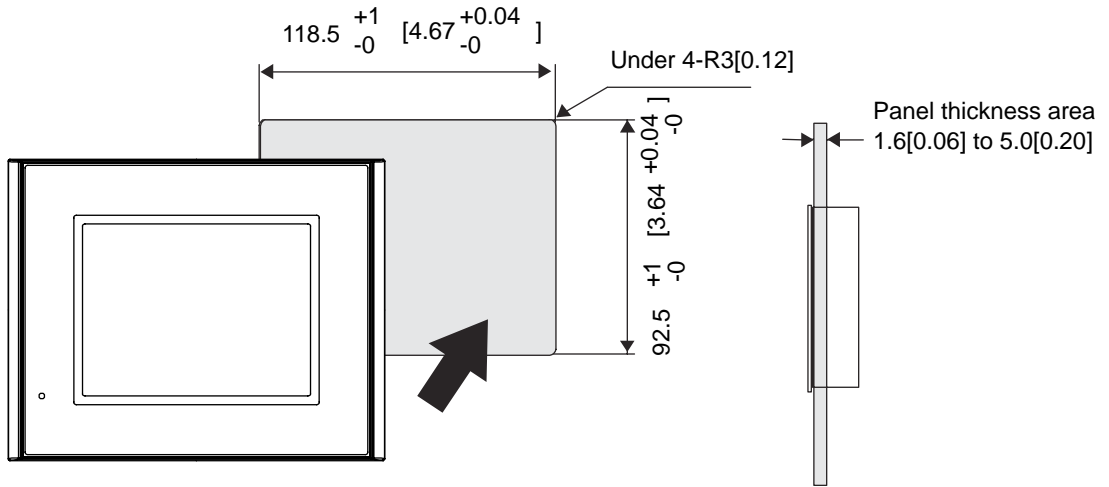

■ Installation Fasteners

Unit: mm[in.]

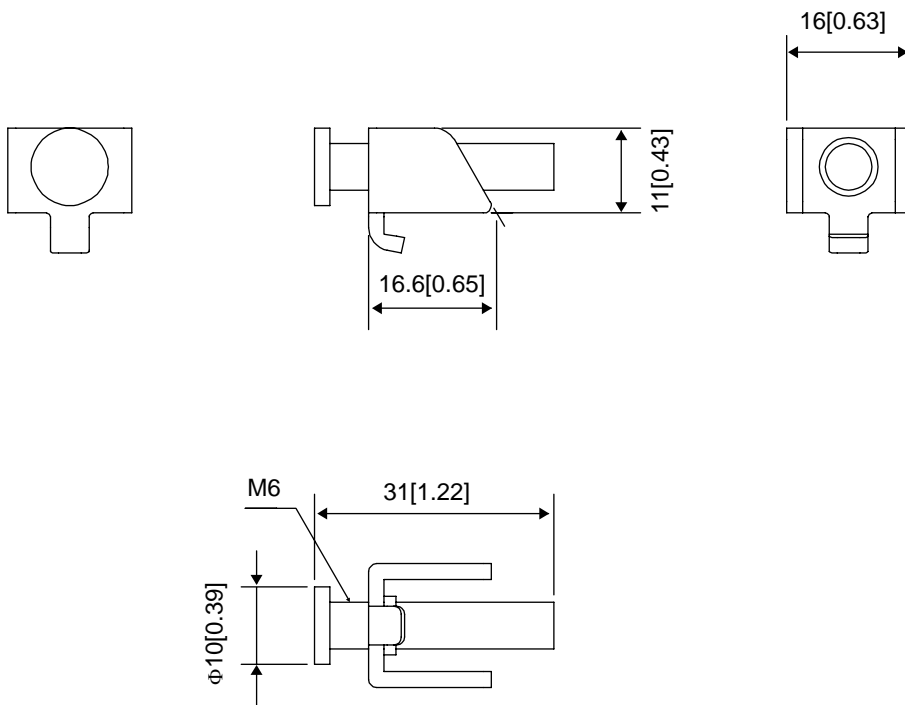

4.2 GP-3300 Series

4.2.1 General Specifications

■Electrical Specifications

		AGP-3300*/3301*	AGP-3302*
Power Supply	Input Voltage	DC24V	
	Rated Voltage	DC19.2 to 28.8V	
	Allowable Voltage Drop	5ms (max.)	10ms (max.)
	Power Consumption	26W (max.)	18W (max.)
	In-Rush Current	30A (max.)	
Voltage Endurance		AC1000V 20mA for 1 minute (between charging and FG terminals)	
Insulation Resistance		DC500V 10M Ω (min.) (between charging and FG terminals)	

■Environmental Specifications

Physical	Surrounding Air Temperature	0 to +50°C*1
	Storage Temperature	-20 to +60°C
	Ambient Humidity	10 to 90% RH (Wet bulb temperature: 39°C max. - no condensation.)
	Storage Humidity	10 to 90% RH (Wet bulb temperature: 39°C max. - no condensation.)
	Dust	0.1mg/m ³ and below (non-conductive levels)
	Pollution Degree	For use in Pollution Degree 2 environment
	Atmosphere	Free of corrosive gases
	Air Pressure Vibration Resistance (availability altitude)	800 to 1114hPa (2,000 meters above sea-level and below)
Mechanical	Vibration Resistance	IEC61131-2 compliant 5 to 9Hz single-amplitude 3.5mm 9 to 150Hz constant-accelerated velocity 9.8m/s ² X,Y,Z directions for 10 cycle (100 minute)
	Concussion Resistance	IEC61131-2 compliant (147m/s ² X,Y,Z directions for 3 time)
Electrical	Noise Immunity	Noise Voltage: 1000V _{P-P} Pulse Duration: 1 μ s Rise Time: 1ns (via noise simulator)
	Electrostatic Discharge Immunity	6kV (complies with EN 61000-4-2 Level 3)

*1 Extended use in environments where Surrounding air temperature is 40°C or higher may degrade the display quality and result in decreased contrast.

■ Structural Specifications

Installation	Grounding	Grounding resistance of 100Ω 2mm ² or thicker wire, or your country's applicable standard. (Same for FG and SG terminals)
	Structure* ¹	Rating: Equivalent to IP65f NEMA #250 TYPE 4X/13 (Front surface at panel embedding) Feature size: All-in-one Installation configuration: Panel embedding
	Cooling Method	Natural air circulation
	Weight Approx.	1.0kg[2.2lb] max. (unit only) 1.2kg[2.6lb] max (DIO/FLEX NETWORK board type)
	External Dimensions	W167.5mm[6.59in] X H135mm[5.31in] X D59.5mm[2.34in]
	Panel Cut Dimensions	W156.0mm[6.14in] X H123.5mm[4.86in] ^{*2} Panel Thickness : 1.6mm[0.06in] to 5.0mm[0.20in]

*1 The front face of the GP unit, installed in a solid panel, has been tested using conditions equivalent to the standards shown in the specification. Even though the GP unit's level of resistance is equivalent to these standards, oils that should have no effect on the GP can possibly harm the unit. This can occur in areas where either vaporized oils are present, or where low viscosity cutting oils are allowed to adhere to the unit for long periods of time. If the GP's front face protection sheet becomes peeled off, these conditions can lead to the ingress of oil into the GP and separate protection measures are suggested.

Also, if non-approved oils are present, it may cause deformation or corrosion of the front panel's plastic cover. Therefore, prior to installing the GP be sure to confirm the type of conditions that will be present in the GP's operating environment.

If the installation gasket is used for a long period of time, or if the unit and its gasket are removed from the panel, the original level of the protection cannot be guaranteed. To maintain the original protection level, be sure to replace the installation gasket regularly.

*2 As for dimensional tolerance everything +1/-0mm[+0.04/-0in] and R in angle are below R3[R0.12in].

4.2.2 Performance Specifications

■ Performance Specifications

		AGP-3300*	AGP-3301*	AGP-3302B
Application ^{*1}		FLASH EPROM 6MB		
Data Backup		SRAM 320K byte		SRAM 128K byte
		Used lithium battery for backup memory		
Interface	Serial Interface	COM1: RS232C/RS422/RS485 Asynchronous Transmission: Data Length: 7 bit/8 bit Parity: none, Odd or Even Stop Bit: 1bit/2bit Data transmission Speed: 2400bps to 115.2Kbps Connector: DSUB-9pin plug		COM1: RS232C Asynchronous Transmission Data Length: 7 bit/8 bit Parity: none, Odd or Even Stop Bit: 1bit/2bit Data transmission Speed: 2400 bps to 115.2 Kbps Connector: DSUB-9pin plug
		COM2: RS422/RS485 Asynchronous Transmission Data Length: 7 bit/8 bit Parity: none, Odd or Even Stop Bit: 1bit/2bit Data transmission Speed: 2400 bps to 115.2 Kbps 187.5 Kbps(MPI) Connector: DSUB-9pin socket		COM2: RS422/RS485 Asynchronous Transmission Data Length: 7bit/8bit Parity: none, Odd or Even Stop Bit: 1bit/2bit Data transmission Speed: 2400 bps to 115.2 Kbps 187.5 Kbps (MPI) Connector: DSUB-9pin plug
	Ethernet Interface	Ethernet (IEEE802.3u,10BASE-T/100BASE-TX) Connector: modular jack connector (RJ-45)		—
	Expansion Unit Interface	Expansion Unit Interface (external/internal)		Expansion Unit Interface (external only)
	USB Host Interface	Conforms to USB1.1.(TYPE-A conn.) x 1 Power Supply Voltage: DC5V ± 5% Output Current: 500mA(max.) Communication Distance:5m(max.)		
	CF Card Interface	Compact Flash CF Card Slot (TYPE-II)		—
Clock Accuracy ^{*2}		± 65 seconds/ month (at room temperature)		
Control Memory ^{*3}	Variable Area	64 KB SRAM (uses lithium battery)		
	Program Area	132 KB FLASH EPROM		

*1 It is user active capacity.

- *2 The GP's internal clock has a slight error. At normal operating temperatures and conditions, with the GP operating from its lithium battery, the degree of error is 65 seconds per month. Variations in operating conditions and battery life can cause this error to vary from -380 to +90 seconds per month. For systems where this degree of error will be a problem, the user should be sure to monitor this error and make adjustments when required.
- *3 Available only in units supporting logic programs

NOTE

- When the message "RAAA051 Low battery" is displayed, supply power to the display unit and fully charge the battery. The battery charges within 24 hours to a level which allows backup operation. Completing a full charge requires about 96 hours (4 days).
- A Lithium battery's lifetime is: 10 years when the battery's ambient temperature is 40°C or less. 4.1 years when the battery's ambient temperature is 50°C or less. 1.5 years when the battery's ambient temperature is 60°C or less.

When used for backup:

Approximately 100 days, with a fully charged battery.

Approximately 6 days, with a half-charged battery.

- 1:1 connections using a cross cable may not be possible depending on the type of personal computer and network card you are using.
Make sure to use a hub for the Ethernet Communication.

■ Display Specifications

	AGP-3300L AGP-3301L	AGP-3300S AGP-3301S	AGP-3300T	AGP-3302B
Display Type	Monochrome LCD	STN Color LCD	TFT Color LCD	Blue-mode Monochrome LCD
Resolution	W320 X H240 pixels			
Dot pitch	W0.36mm[0.01in] X H0.36mm[0.01in]			
Effective Display Area	W115.2mm[4.54in] X H86.4mm[3.40in]			
Color/Shade level	Black and White (16 Shades)	4,096 Colors	65,536 Colors (No blink) 16,384 Colors (Enables blink feature)	16 Shades
Backlight	CCFL (Not user replaceable. When replacement is required, contact your local GP distributor.)			
Brightness control	8 levels of adjustment available via touch panel			
Contrast Adjustment	8 levels of adjustment available via touch panel		Not applicable	8 levels of adjustment available via touch panel
Display Service Life	MTBF value: 50,000hrs. (TYP) (Backlight display service life is not included.)			
Backlight Service Life	58,000hrs. or more (at 25°C and continuous operation - period until backlight brightness decreases to 50% or backlight starts to flicker)	75,000hrs. or more (at 25°C and continuous operation - period until backlight brightness decreases to 50% or backlight starts to flicker)	50,000hrs. or more (at 25°C and continuous operation - period until backlight brightness decreases to 50% or backlight starts to flicker)	58,000hrs. or more (at 25°C and continuous operation - period until backlight brightness decreases to 50% or backlight starts to flicker)
Language Fonts	Japanese: 6962 (JIS Standards 1 & 2)(including 607 non-kanji characters) ANK: 158 (Korean fonts, Simplified Chinese and Taiwanese traditional Chinese fonts are downloadable.			
Text composition	Character Sizes	Standard font: 8X8, 8X16, 16X16 and 32X32 dot fonts Stroke font: 6 to 127dot fonts		
	Font Sizes	Standard font: Width can be expanded up to 8 times. Height can be expanded up to 8 times ^{*1}		
Text	8 X 8 dots	40 Char. X 30 rows		
	8 X 16 dots	40 Char. X 15 rows		
	16 X 16 dots	20 Char. X 15 rows		
	32 X 32 dots	10 Char. X 7 rows		

*1 The other font sizes can be set up by software.

■ Touch Panel Specifications

Type	Resistive Film (analog)
Resolution	1024 X 1024
Service Life	1,000,000 times or more

4.2.3 Interface Specifications

This section describes the specifications of each interface of the GP Series unit.

- IMPORTANT**
- The GP unit's serial Interface is not isolated. When the host (PLC) unit is also not isolated, be sure to connect the #5 SG (Signal Ground) terminal to reduce the risk of damaging the RS232C/RS422/RS485 circuit.
 - When connecting an external device to the GP using the SG terminal, be sure to check that no short-circuit loop is created when you setup the system.

- NOTE**
- When isolation is necessary, you can use the RS232C isolation unit (CA3-ISO232-01) on COM1.

■ AGP-3300*/3301*

◆ Serial Interfaces (COM1)

This interface is used to connect an RS232C/RS422/RS485^{*1} cable. D-sub 9-pin plug connector is used.

<GP unit side>

GP Connector	XM2C-0942-502LX <OMRON Co.>
--------------	-----------------------------

<Cable side>

Recommended Cable Connector	XM2D-0901 <OMRON Co.>
Recommended Cable Cover	XM2S-0913 <OMRON Co.>
Recommended Jack Screw	XM2Z-0073 <OMRON Co.>
Interfit Bracket	#4-40 inch screws are used.

In the case of RS232C

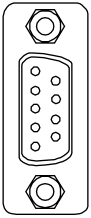
Pin Arrangement	Pin No.	RS232C		
		Signal Name	Direction	Meaning
 <p>(GP unit side)</p>	1	CD	Input	Carrier Detect
	2	RD(RXD)	Input	Receive Data
	3	SD(TXD)	Output	Send Data
	4	ER(DTR)	Output	Data Terminal Ready
	5	SG	-	Signal Ground
	6	DR(DSR)	Input	Data Set Ready
	7	RS(RTS)	Output	Request to Send
	8	CS(CTS)	Input	Send Possible
	9	CI(RI)/VCC	Input/-	Called status display +5V±5% Output 0.25A ^{*2}
	Shell	FG	-	Frame Ground (Common with SG)

*1 Communication method is switched via software.

*2 The RI/VCC selection for Pin #9 is switched via software. The VCC output is not protected against overcurrent. To prevent damage or a unit malfunction, use only the rated current.

In the case of RS422/RS485

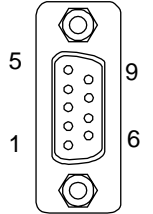
Pin Arrangement	Pin No.	RS422/RS485		
		Signal Name	Direction	Meaning
 <p>(GP unit side)</p>	1	RDA	Input	Receive Data A(+)
	2	RDB	Input	Receive Data B(-)
	3	SDA	Output	Send Data A(+)
	4	ERA	Output	Data Terminal Ready A(+)
	5	SG	-	Signal Ground
	6	CSB	Input	Send Possible B(-)
	7	SDB	Output	Send Data B(-)
	8	CSA	Input	Send Possible A(+)
	9	ERB	Output	Data Terminal Ready B(-)
	Shell	FG	-	Frame Ground (Common with SG)

◆Serial Interface (COM2)

This interface is used to connect an RS422/RS485 serial cable. A D-sub 9-pin socket connector is used.

<GP unit side>

GP Connector	XM3B-0942-502LX <OMRON Co.>
--------------	-----------------------------

<Cable side>

Recommended Cable Connector	XM2A-0901 <OMRON Co.>
Recommended Cable Cover	XM2S-0913 <OMRON Co.>
Recommended Jack Screw	XM2Z-0073 <OMRON Co.>
Interfit Bracket	#4-40 inch screws are used.

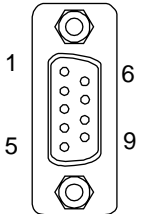
Pin Arrangement	Pin No.	RS422/RS485		
		Signal Name	Direction	Meaning
 <p>(GP unit side)</p>	1	TRMRX	-	Termination (Receiver side: 100Ω)
	2	RDA	Input	Receive Data A(+)
	3	SDA	Output	Send Data A(+)
	4	RS(RTS)	Output	Request for Send
	5	SG	-	Signal Ground
	6	VCC	-	+5V±5% Output 0.25A *1
	7	RDB	Input	Receive DataB(-)
	8	SDB	Output	Send Data B(-)
	9	TRMTX	-	Termination (Receiver side: 100Ω)
	Shell	FG	-	Frame Ground (Common with SG)

*1 The VCC output for Pin #6 is not protected against overcurrent. To prevent damage or a unit malfunction, use only the rated current.

■AGP-3302

◆Serial Interface (COM1)

This interface is used to connect an RS232C serial cable. A D-sub 9-pin socket connector is used.

<GP unit side>

GP Connector	XM2C-0942-502LX <OMRON Co.>
--------------	-----------------------------

<Cable side>

Recommended Cable Connector	XM2D-0901 <OMRON Co.>
Recommended Cable Cover	XM2S-0913 <OMRON Co.>
Recommended Jack Screw	XM2Z-0073 <OMRON Co.>
Interfit Bracket	#4-40 inch screws are used.

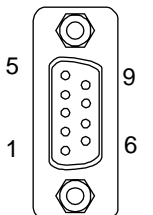
Pin Arrangement	Pin No.	RS232C		
		Signal Name	Direction	Meaning
 <p>(GP unit side)</p>	1	CD	Input	Carrier Detect
	2	RD(RXD)	Input	Receive Data
	3	SD(TXD)	Output	Send Data
	4	ER(DTR)	Output	Data Terminal Ready
	5	SG	-	Signal Ground
	6	DR(DSR)	Input	Data Set Ready
	7	RS(RTS)	Output	Request to Send
	8	CS(CTS)	Input	Send Possible
	9	CI(RI)/VCC	Input/-	Called status display +5V±5% Output 0.25A *1
	Shell	FG	-	Frame Ground (Common with SG)

*1 The RI/VCC selection for Pin #9 is switched via software. The VCC output is not protected against overcurrent. To prevent damage or a unit malfunction, use only the rated current.

◆Serial Interface (COM2)

This interface is used to connect an RS422 serial cable. A D-sub 9-pin socket connector is used.

<GP unit side>

GP Connector	XM2C-0942-502LX <OMRON Co.>
--------------	-----------------------------

<Cable side>

Recommended Cable Connector	XM2D-0901 <OMRON Co.>
Recommended Cable Cover	XM2S-0913 <OMRON Co.>
Recommended Jack Screw	XM2Z-0073 <OMRON Co.>
Interfit Bracket	#4-40 inch screws are used.

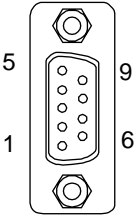
Pin Arrangement	Pin No.	RS422		
		Signal Name	Direction	Meaning
 <p>(GP unit side)</p>	1	RDA	Input	Receive Data A(+)
	2	RDB	Input	Receive Data B(-)
	3	SDA	Output	Send Data A(+)
	4	ERA	Output	Data Terminal Ready A(+)
	5	SG	-	Signal Ground
	6	CSB	Input	Send Possible B(-)
	7	SDB	Output	Send Data B(-)
	8	CSA	Input	Send Possible A(+)
	9	ERB	Output	Data Terminal Ready B(-)
	Shell	FG	-	Frame Ground (Common with SG)

4.2.4 Dimensions

The following dimensions apply to all AGP-3300* Series units.

The dimensions of the AGP-3301*/3302B are the same. The following drawings show the AGP-3300*.

■ External Dimensions

Unit: mm[in.]

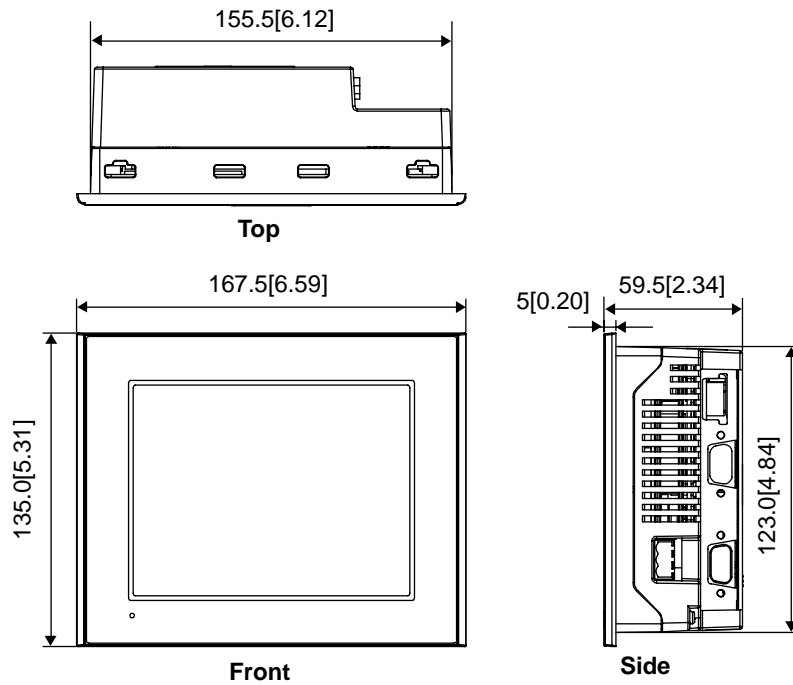

■ Installation Fasteners Attached Dimensions

Unit: mm[in.]

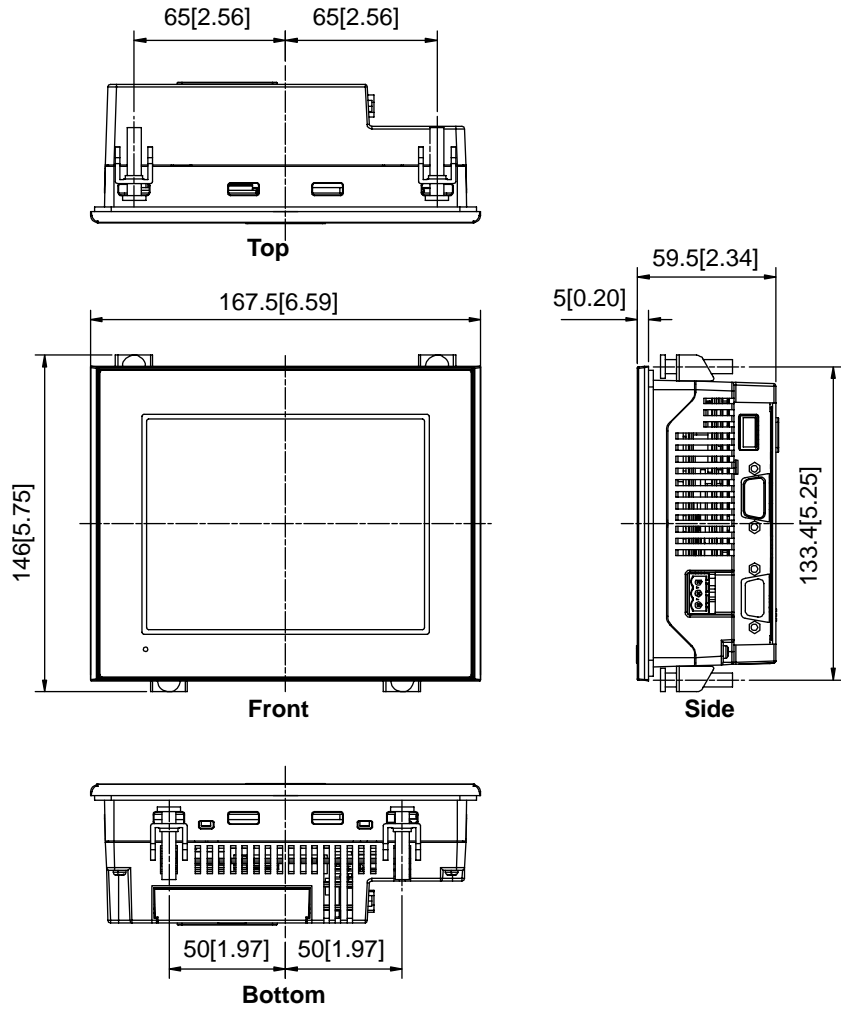

■ Cable Attached Dimensions

Unit: mm[in.]

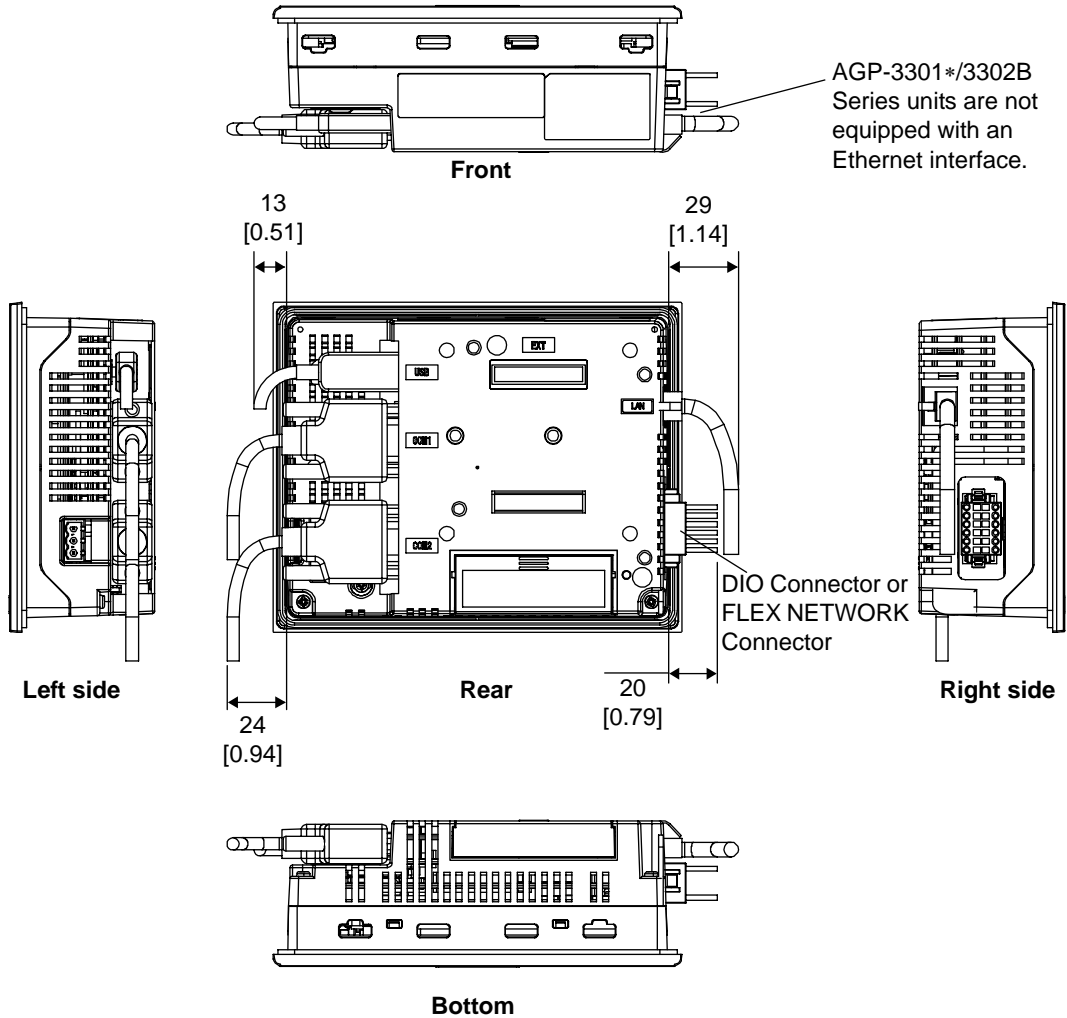

(The figure shows the DIO board type unit.)

IMPORTANT

- All the above values are designed in case of cable bending. The dimensions given here are representative values depending on the type of connection cable used. Therefore, they are all intended for reference only.

Unit:mm[in.]

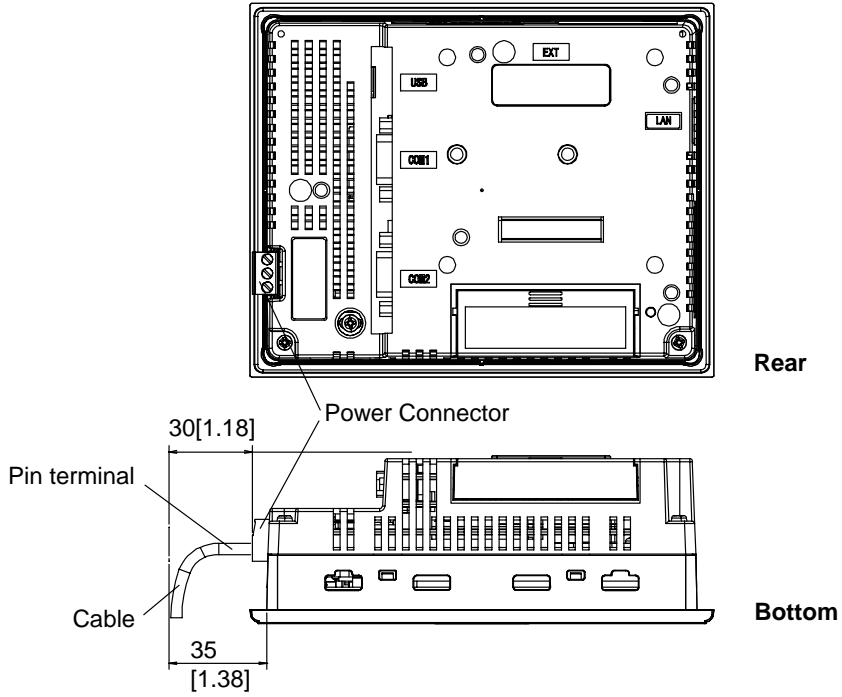

IMPORTANT

- Depending on the type of connection cable used the dimensions shown above will change. The dimensions given here are representative values and are intended for reference only.

■ Panel Cut Dimensions

Unit: mm[in.]

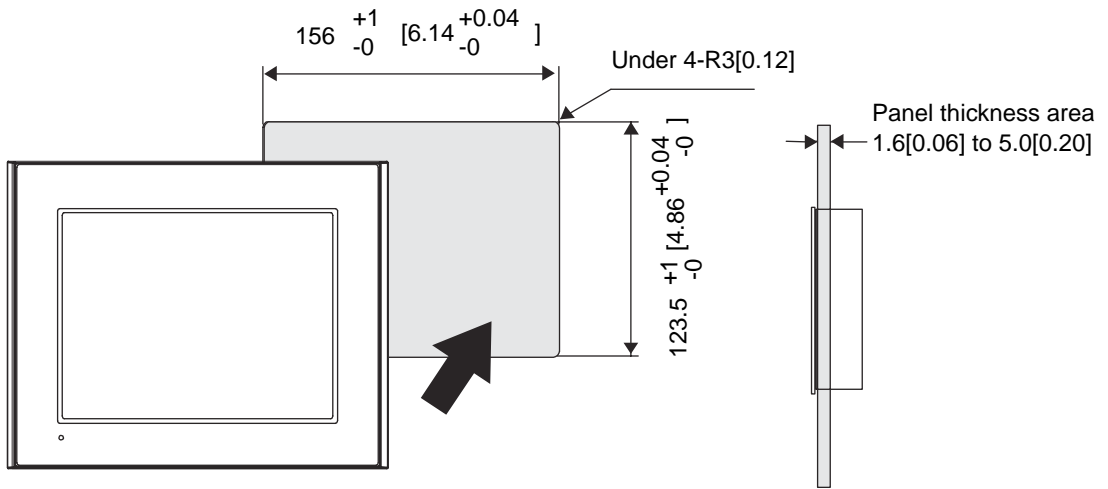

■ Installation Fasteners

Unit: mm[in.]

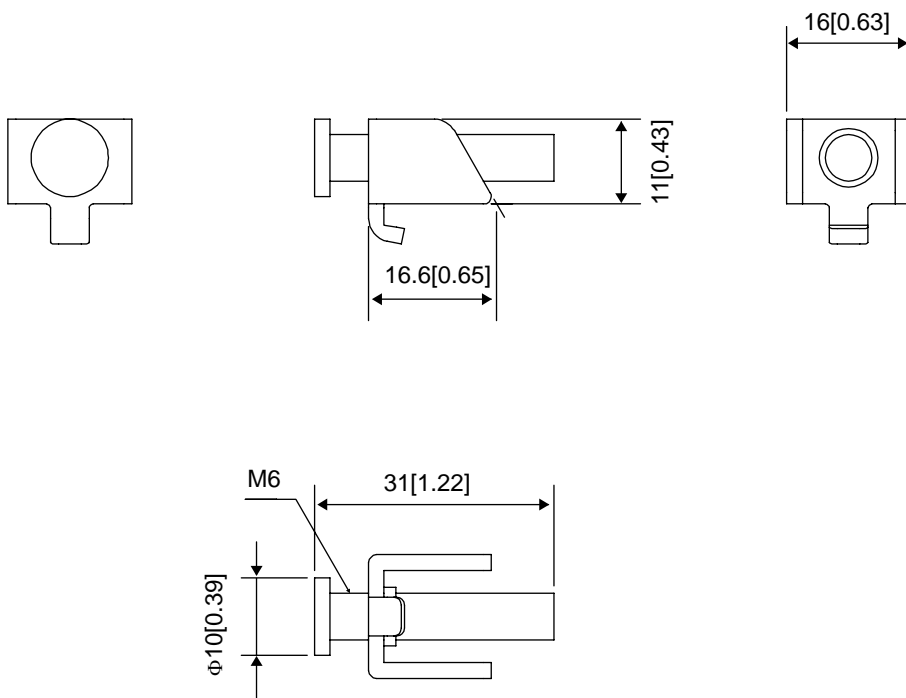

4.3 GP-3400 Series

4.3.1 General Specifications

■Electrical Specifications

		GP-3400 Series
Power Supply	Input Voltage	DC24V
	Rated Voltage	DC19.2 to 28.8V
	Allowable Voltage	10m (max.)
	Power Consumption	28W (max.)
	In-Rush Current	30 (max.)
Voltage Endurance		AC1000V 20mA for 1 minute (between charging and FG terminals)
Insulation Resistance		DC500V 10MΩ (min.) (between charging and FG terminals)

■Environmental Specifications

Physical	Surrounding Air Temperature	0 to +50°C*1
	Storage Temperature	-20 to +60°C
	Ambient Humidity	10 to 90% RH (Wet bulb temperature: 39°C max. - no condensation.)
	Storage Humidity	10 to 90% RH (Wet bulb temperature: 39°C max. - no condensation.)
	Dust	0.1mg/m ³ and below (non-conductive levels)
	Pollution Degree	For use in Pollution Degree 2 environment
	Atmosphere	Free of corrosive gases
	Air Pressure Vibration Resistance (availment altitude)	800 to 1114hPa (2,000 meters above sea-level and below)
Mechanical	Vibration Resistance	IEC61131-2 compliant 5 to 9Hz single-amplitude 3.5mm 9 to 150Hz constant-accelerated velocity 9.8m/s ² X,Y,Z directions for 10 cycle (100 minute)
	Concussion Resistance	IEC61131-2 compliant (147m/s ² X,Y,Z directions for 3 time)
Electrical	Noise Immunity	Noise Voltage: 1000V _{P.P} Pulse Duration: 1μs Rise Time: 1ns (via noise simulator)
	Electrostatic Discharge Immunity	6kV (complies with EN 61000-4-2 Level 3)

*1 When using STN Color LCD model in an environment where the temperature becomes or exceeds 40°C for an extended period of time, the screen contrast level may decrease from its original level of brightness.

■ Structural Specifications

Installation	Grounding	Grounding resistance of 100Ω 2mm ² or thicker wire, or your country's applicable standard. (Same for FG and SG terminals)
	Structure* ¹	Rating: Equivalent to IP65f NEMA #250 TYPE 4X/13 (Front surface at panel embedding) Feature size: All-in-one Installation configuration: Panel embedding
	Cooling Method	Natural air circulation
	Weight Approx.	1.8kg[4.0lb]max. (unit only) 2.0kg[4.4lb] max (DIO/FLEX NETWORK board type)
	External Dimensions	W215mm[8.46in] X H170mm[6.69in] X D60mm[2.36in]
	Panel Cut Dimensions	W204.5mm[8.05in] X H159.5mm[6.28in] ^{*2} Panel Thickness : 1.6mm[0.06in] to 10.0mm[0.39in]

*1 The front face of the GP unit, installed in a solid panel, has been tested using conditions equivalent to the standards shown in the specification. Even though the GP unit's level of resistance is equivalent to these standards, oils that should have no effect on the GP can possibly harm the unit. This can occur in areas where either vaporized oils are present, or where low viscosity cutting oils are allowed to adhere to the unit for long periods of time. If the GP's front face protection sheet becomes peeled off, these conditions can lead to the ingress of oil into the GP and separate protection measures are suggested.

Also, if non-approved oils are present, it may cause deformation or corrosion of the front panel's plastic cover. Therefore, prior to installing the GP be sure to confirm the type of conditions that will be present in the GP's operating environment.

If the installation gasket is used for a long period of time, or if the unit and its gasket are removed from the panel, the original level of the protection cannot be guaranteed. To maintain the original protection level, be sure to replace the installation gasket regularly.

*2 As for dimensional tolerance everything +1/-0mm[+0.04/-0in] and R in angle are below R3[R0.12in].

4.3.2 Performance Specifications

■ Performance Specifications

		AGP-3400*	AGP-3450T
Application ^{*1}		FLASH EPROM 8MB	
Data Backup		SRAM 320K byte	
		Used lithium battery for backup memory	
Interface	Serial Interface	COM1: RS232C/RS422/RS485 Asynchronous Transmission: Data Length: 7 bit/8 bit Parity: none, Odd or Even Stop Bit: 1bit/2bit Data transmission Speed: 2400 bps to 115.2 Kbps Connector: D-SUB-9pin plug	
		COM2: RS422/RS485 Asynchronous Transmission Data Length: 7 bit/8 bit Parity: none, Odd or Even Stop Bit: 1bit/2bit Data transmission Speed: 2400 bps to 115.2 Kbps 187.5 Kbps(MPI) Connector: DSUB-9pin plug	
	Ethernet Interface	IEEE802.3u,10BASE-T/100BASE-TX Connector: modular jack connector (RJ-45)	
	Expansion Unit Interface	Expansion Unit Interface (external/internal)	
	USB Host Interface	Conforms to USB1.1.(TYPE-A conn.) x 1 Power Supply Voltage: DC5V ± 5% Output Current: 500mA(max.) Communication Distance:5m(max.)	
	Expansion Memory Interface	0.6mm pitch 80pin stacking port	
	CF Card Interface	Compact Flash CF Card Slot (TYPE-II)	
	Video Input Interface	-	NTSC: 59.9Hz PAL: 50Hz Connector: RCA 75Ω
	Sound Input Interface	-	MIC input/LINE input (Change with S/W) Connector: MINI-JACK Φ3.5
	Sound Output Interface	Speaker Output 70mW(Rated Load: 8Ω, Frequency: 1KHz) Connector: Two piece type terminal block	
	AUX Input/ Output Interface	Alarm Output, RUN Output, Buzzer Output Rated Voltage: DC24V Rated Current: 50mA	
		Remote Reset Input Input Voltage: DC24V Input Current: 6mA Operating Voltage: (When ON) Min.: DC9V, (When OFF) Max. DC2.5V Two piece type terminal block	
	Clock Accuracy ^{*2}		±65 seconds/ month (at room temperature)

Control Memory	Variable Area	64 KB SRAM (uses lithium battery)
	Program Area	132 KB FLASH EPROM

- *1 It is user active capacity.
- *2 The GP's internal clock has a slight error. At normal operating temperatures and conditions, with the GP operating from its lithium battery, the degree of error is 65 seconds per month. Variations in operating conditions and battery life can cause this error to vary from -380 to +90 seconds per month. For systems where this degree of error will be a problem, the user should be sure to monitor this error and make adjustments when required.

NOTE

- When the message "RAAA051 Low battery" is displayed, supply power to the display unit and fully charge the battery. The battery charges within 24 hours to a level which allows backup operation. Completing a full charge requires about 96 hours (4 days).
- A Lithium battery's lifetime is: 10 years when the battery's ambient temperature is 40°C or less. 4.1 years when the battery's ambient temperature is 50°C or less. 1.5 years when the battery's ambient temperature is 60°C or less.

When used for backup:

Approximately 100 days, with a fully charged battery.

Approximately 6 days, with a half-charged battery.

- 1:1 connections using a cross cable may not be possible depending on the type of personal computer and network card you are using.

Make sure to use a hub for the Ethernet Communication.

■ Display Specifications

		AGP-3400S	AGP-3400T	AGP-3450T
Display Type		STN Color LCD	TFT Color LCD	
Resolution		W640 X H480 pixels		
Dot pitch		W0.237mm[0.01in] X H0.237mm[0.01in]		
Effective Display Area		W153.7mm[6.05in] X H115.8mm[4.56in]		
Color/Shade level		4,096 Colors	65,536 Colors(No blink) 16,384 Colors(Enables blink feature)	
Backlight		CCFL		
Brightness control		8 levels of adjustment available via touch panel		
Contrast Adjustment		8 levels of adjustment available via touch panel	Not applicable	
Display Service Life		MTBF value: 50, 000hrs. or more (Backlight display service life is not included.)	MTBF value: 52, 000hrs. or more (Backlight display service life is not included.)	
Backlight Service Life		54,000hrs. or more (at 25°C and continuous operation - period until backlight brightness decreases to 50% or backlight starts to flicker)		
Language Fonts		Japanese: 6962 (JIS Standards 1 & 2)(including 607 non-kanji characters) ANK: 158 (Korean fonts, Simplified Chinese and Taiwanese traditional Chinese fonts are downloadable.		
Text composition	Character Sizes	Standard font: 8X8, 8X16, 16X16 and 32X32 dot fonts Stroke font: 6 to 127dot fonts		
	Font Sizes	Standard font: Width can be expanded up to 8 times. Height can be expanded up to 8 times ^{*1}		
Text	8 X 8 dots	80 Char. X 60 rows		
	8 X 16 dots	80 Char. X 30 rows		
	16 X 16 dots	40 Char. X 30 rows		
	32 X 32 dots	20 Char. X 15 rows		

*1 The other font sizes can be set up by software.

■ Touch Panel Specifications

Type	Resistive Film (analog)
Resolution	1024 X 1024
Service Life	1,000,000 times or more

4.3.3 Interface Specifications

This section describes the specifications of each interface of the GP Series unit.

- IMPORTANT**
- The GP unit's serial interface is not isolated. When the host (PLC) unit is also not isolated, be sure to connect the Pin #5 SG (Signal Ground) terminal to reduce the risk of damaging the RS232C/RS422/RS485 circuit.
 - When connecting an external device to the GP using the SG terminal, be sure to check that no short-circuit loop is created when you setup the system.

- NOTE**
- When isolation is necessary, you can use either RS232C isolation unit (CA3-ISO232-01) on COM1 or RS485 isolation unit (CA3-ISO485-01) on COM2.

Serial Interfaces

Serial Interface (COM1)

This interface is used to connect an RS232C/RS422/RS485 serial cable. A D-sub 9-pin socket connector is used.

Communication method is switched via software

<GP unit side>

GP Connector	XM2C-0942-502LX <OMRON Co.>
--------------	-----------------------------

<Cable side>

Recommended Cable Connector	XM2D-0901 <OMRON Co.>
Recommended Cable Cover	XM2S-0913 <OMRON Co.>
Recommended Jack Screw	XM2Z-0073 <OMRON Co.>
Interfit Bracket	#4-40 inch screws are used.

In the case of RS232C

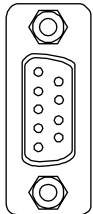
Pin Arrangement	Pin No.	RS232C		
		Signal Name	Direction	Meaning
 <p>(GP unit side)</p>	1	CD	Input	Carrier Detect
	2	RD(RXD)	Input	Receive Data
	3	SD(TXD)	Output	Send Data
	4	ER(DTR)	Output	Data Terminal Ready
	5	SG	-	Signal Ground
	6	DR(DSR)	Input	Data Set Ready
	7	RS(RTS)	Output	Request to Send
	8	CS(CTS)	Input	Send Possible
	9	CI(RI)/VCC	Input/-	Called status display +5V±5% Output 0.25A *1
	Shell	FG	-	Frame Ground (Common with SG)

*1 The RI/VCC selection for Pin #9 is switched via software. The VCC output is not protected against overcurrent. To prevent damage or a unit malfunction, use only the rated current.

In the case of RS422/RS485

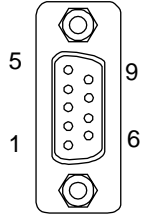
Pin Arrangement	Pin No.	RS422/RS485		
		Signal Name	Direction	Meaning
 <p>(GP unit side)</p>	1	RDA	Input	Receive Data A(+)
	2	RDB	Input	Receive Data B(-)
	3	SDA	Output	Send Data A(+)
	4	ERA	Output	Data Terminal Ready A(+)
	5	SG	-	Signal Ground
	6	CSB	Input	Send Possible B(-)
	7	SDB	Output	Send Data B(-)
	8	CSA	Input	Send Possible A(+)
	9	ERB	Output	Data Terminal Ready B(-)
	Shell	FG	-	Frame Ground (Common with SG)

◆Serial Interface (COM2)

This interface is used to connect an RS422/RS485 serial cable. A D-sub 9-pin plug connector is used.

<GP unit side>

GP Connector	XM3B-0942-502LX <OMRON Co.>
--------------	-----------------------------

<Cable side>

Recommended Cable Connector	XM2A-0901 <OMRON Co.>
Recommended Cable Cover	XM2S-0913 <OMRON Co.>
Recommended Jack Screw	XM2Z-0073 <OMRON Co.>
Interfit Bracket	#4-40 inch screws are used.

Pin Arrangement	Pin No.	RS422/RS485		
		Signal Name	Direction	Meaning
 <p>(GP unit side)</p>	1	TRMRX	-	Termination (Receiver side: 100Ω)
	2	RDA	Input	Receive Data A(+)
	3	SDA	Output	Send Data A(+)
	4	RS(RTS)	Output	Request for Send
	5	SG	-	Signal Ground
	6	VCC	-	+5V±5% Output 0.25A *1
	7	RDB	Input	Receive DataB(-)
	8	SDB	Output	Send Data B(-)
	9	TRMTX	-	Termination (Receiver side: 100Ω)
Shell	FG	-	Frame Ground (Common with SG)	

*1 The VCC output for Pin #6 is not protected against overcurrent. To prevent damage or a unit malfunction, use only the rated current.

■ Sound Output/AUX Input/Output Interface

This interface is used for external reset, alarm output, buzzer output or sound output.

<Cable side>

Applicable Connector	S2L3.5/12/90F <made by Weidmuller>
----------------------	------------------------------------

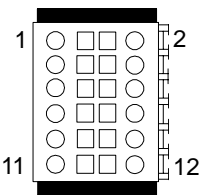
Pin Arrangement	Pin#	Signal Name	Direction	Meaning
 (Cable connection side)	1	RESET IN_A	Input	External Reset Input
	2	RESET IN_B	Input	
	3	RUN+	Output	RUN Signal
	4	RUN-	Output	
	5	ALARM+	Output	ALARM Signal
	6	ALARM-	Output	
	7	BUZZER+	Output	Buzzer Signal
	8	BUZZER-	Output	
	9	NC	-	Not Connected
	10	NC	-	Not Connected
	11	SP	Output	Speaker Out
	12	SP_GND	Output	Speaker Ground

• Input Circuit

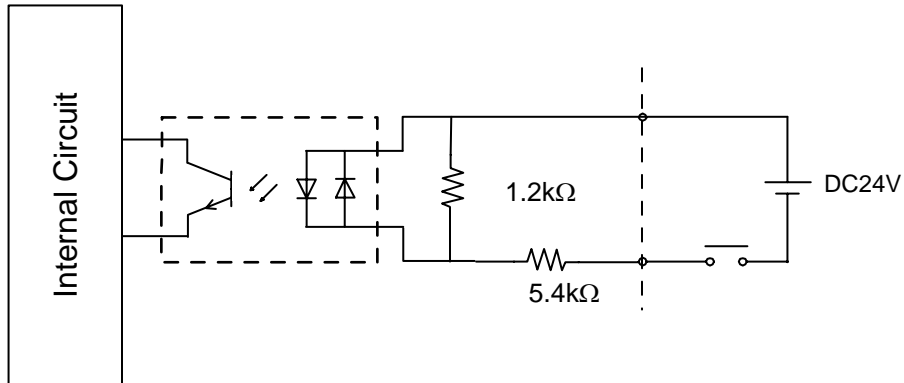

• Output Circuit

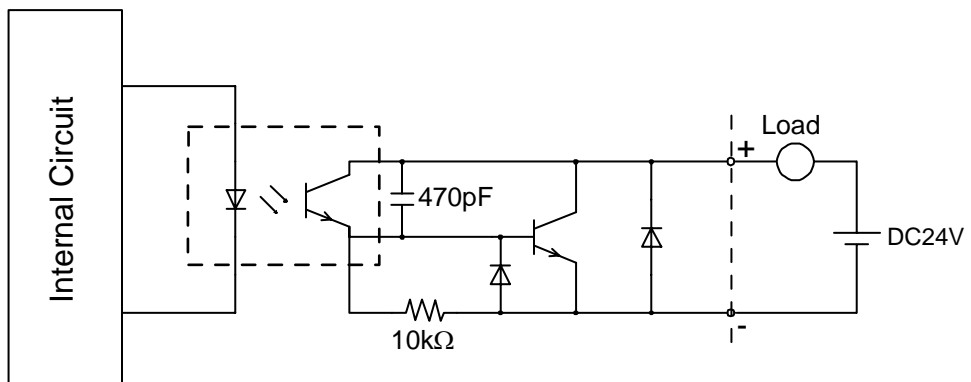

4.3.4 Dimensions

The following dimensions apply to all GP-3400 Series units.

The dimensions of the AGP-3400* are the same. The following drawings show the AGP-3450T.

■ External Dimensions

Unit: mm[in.]

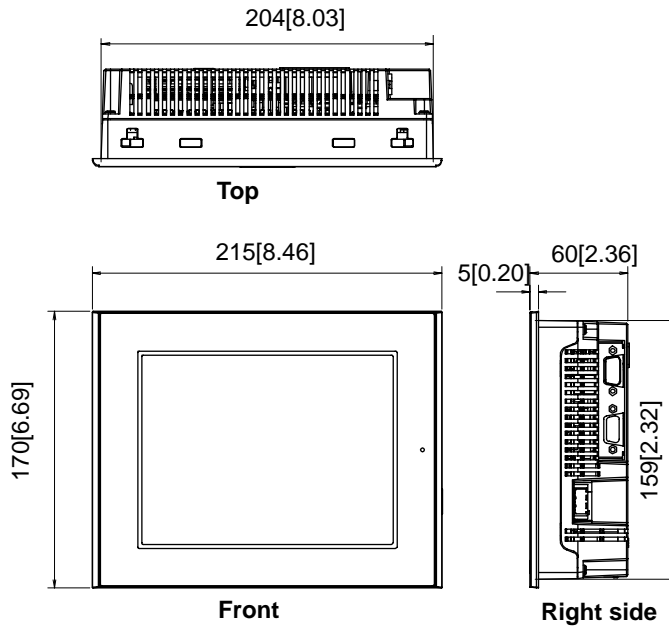

■ Installation Fasteners Attached Dimensions

Unit: mm[in.]

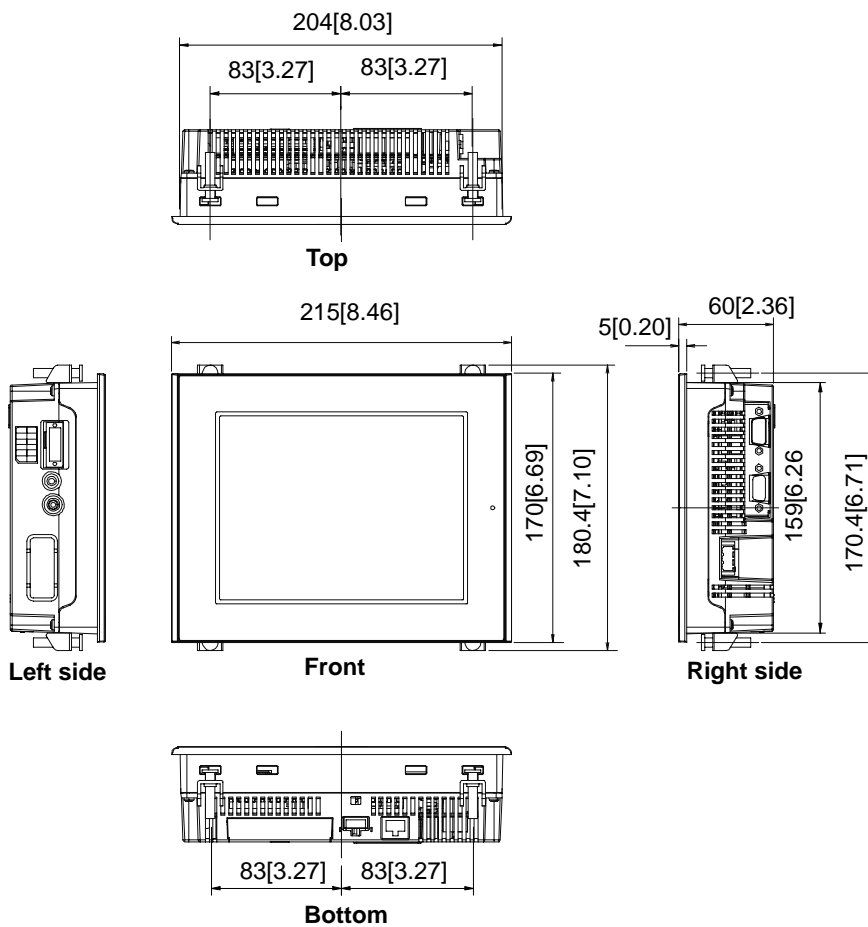

■ Cable Attached Dimensions

Unit:mm[in.]

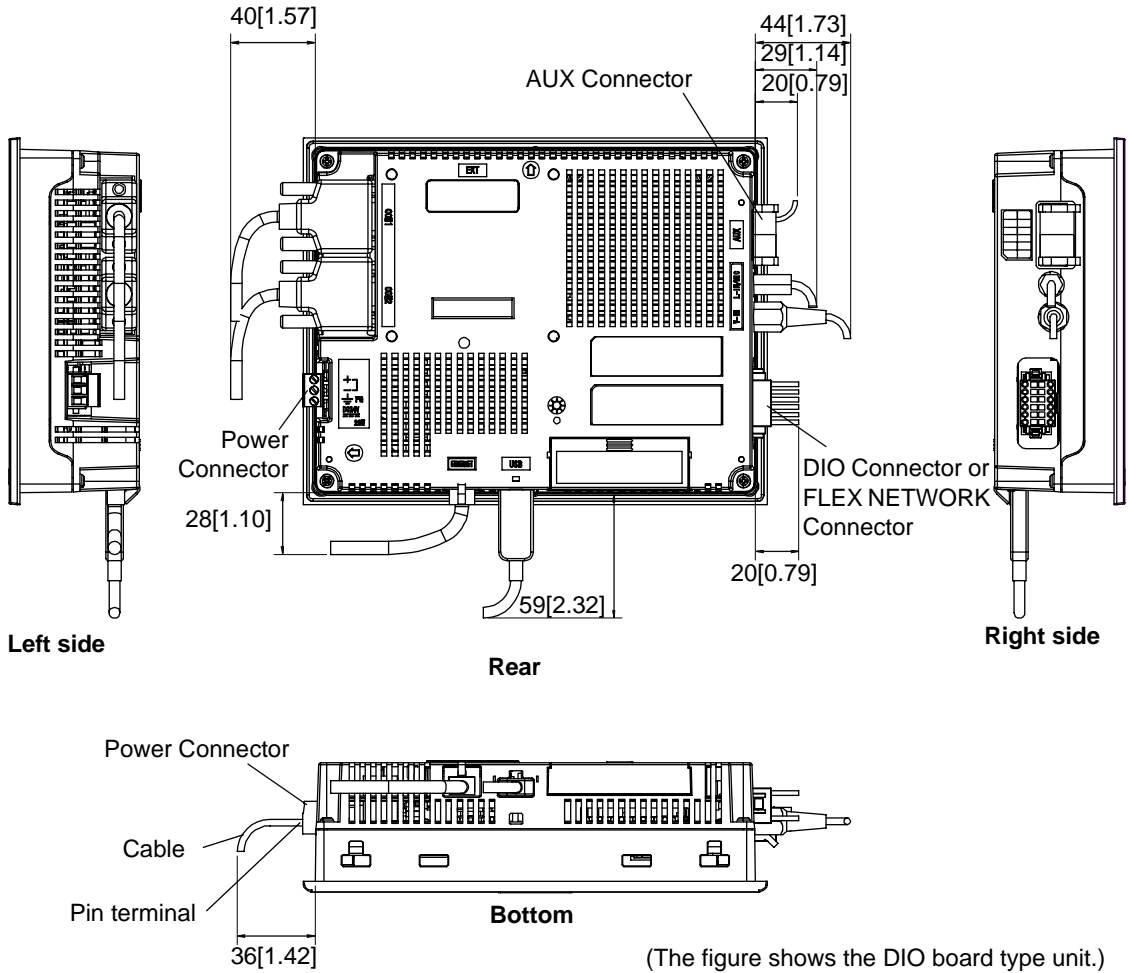

IMPORTANT

- All the above values are designed in case of cable bending. The dimensions given here are representative values depending on the type of connection cable used. Therefore, they are all intended for reference only.

■ Panel Cut Dimensions

Unit: mm[in.]

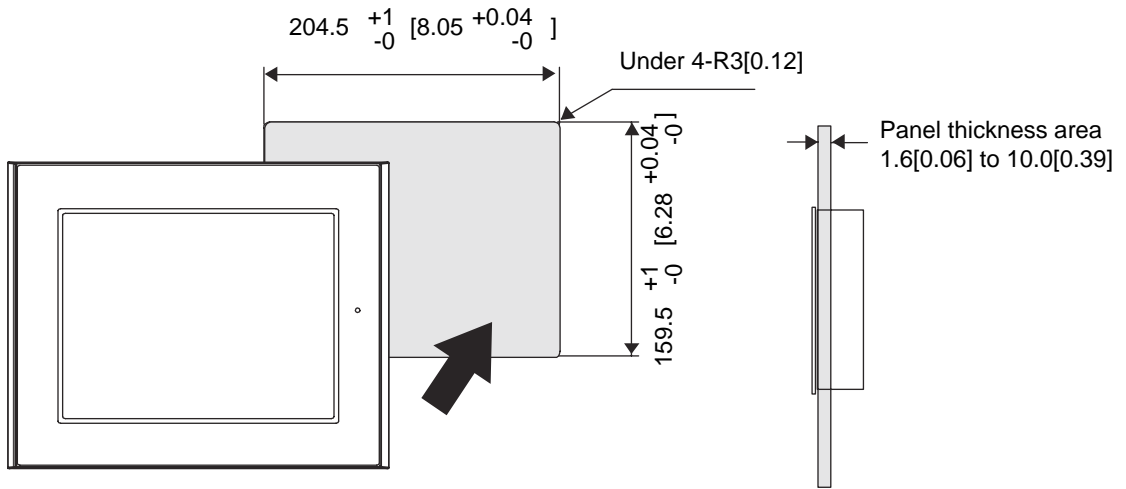

■ Installation Fasteners

Unit: mm[in.]

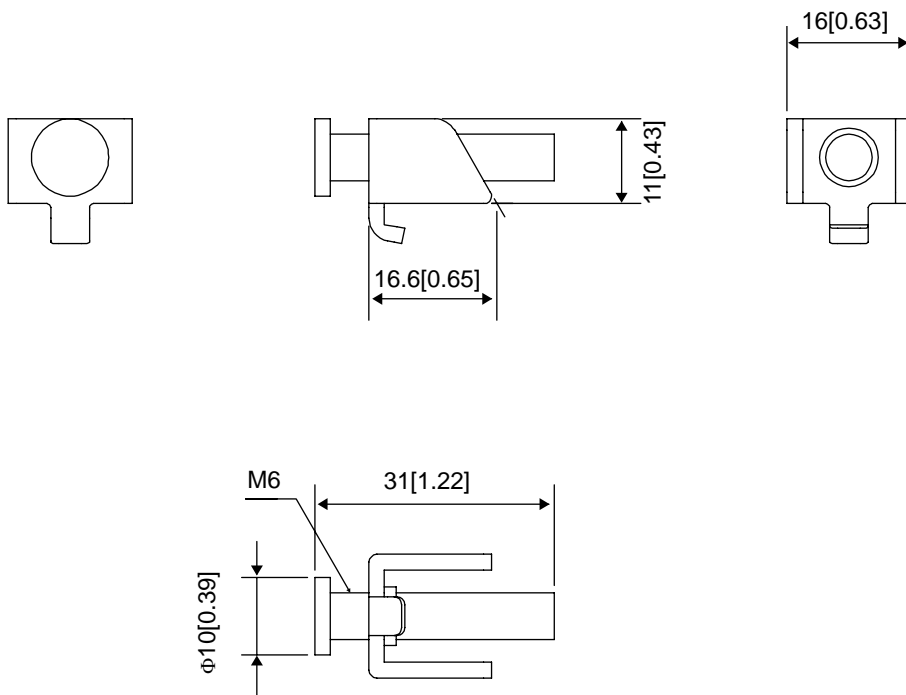

4.4 GP-3500 Series

4.4.1 General Specifications

■Electrical Specifications

		DC model	AC model	
Power Supply	Input Voltage	DC24V	AC100 to 240V	
	Rated Voltage	DC19.2 to 28.8V	AC85 to 265V	
	Rated frequency	-	50/60Hz	
	Rated frequency range	-	40 to 72Hz	
	Allowable Voltage	10ms or less	Shorter than 1cycle (Voltage drop interval must be 1s or more)	
	Power Consumption	AGP-3500T AGP-3510T AGP-3550T AGP-3560T	DC24V 2.08A or less (TYP 1.22A)	AC100V 0.9A or less (TYP 0.58A) AC240V 0.45A or less (TYP 0.29A)
		AGP-3500L AGP-3500S	DC24V 2.08A or less (TYP 1.08A)	AC100V 0.90A or less (TYP 0.45A) AC240V 0.45A or less (TYP 0.26A)
In-Rush Current		30A or less	60A or less	
Voltage Endurance		AC1000V 20mA 1minute (between charging and FG terminals)	AC1500V 20mA 1minute (between charging and FG terminals)	
Insulation Resistance		10MΩ or higher at DC500V(min.) (between charging and FG terminals)	10MΩ or higher at DC500V(min.) (between charging and FG terminals)	

■ Environmental Specifications

Physical	Surrounding Air Temperature	0 to +50°C*1
	Storage Temperature	-20 to +60°C
	Ambient Humidity	10 to 90% RH (Wet bulb temperature: 39°C max. - no condensation.)
	Storage Humidity	10 to 90% RH (Wet bulb temperature: 39°C max. - no condensation.)
	Dust	0.1mg/m ³ and below (non-conductive levels)
	Pollution Degree	For use in Pollution Degree 2 environment
	Atmosphere	Free of corrosive gases
	Air Pressure Vibration Resistance (availment altitude)	800 to 1114hPa (2,000 meters above sea-level and below)
Mechanical	Vibration Resistance	IEC61131-2 compliant 5 to 9Hz single-amplitude 3.5mm 9 to 150Hz constant-accelerated velocity 9.8m/s ² X,Y,Z directions for 10 cycle (100 minute)
	Concussion Resistance	IEC61131-2 compliant (147m/s ² X,Y,Z directions for 3 time)
Electrical	Noise Immunity	Noise Voltage: 1000V _{P-P} (DC model) 1500V _{P-P} (AC model) Pulse Duration: 1μs Rise Time: 1ns (via noise simulator)
	Electrostatic Discharge Immunity	6kV (complies with EN 61000-4-2 Level 3)

*1 When using STN Color LCD model in an environment where the temperature becomes or exceeds 40°C for an extended period of time, the screen contrast level may decrease from its original level of brightness.

■ Structural Specifications

Installation	Grounding	Grounding resistance of 100Ω 2mm ² or thicker wire, or your country's applicable standard. (Same for FG and SG terminals)
	Structure*1	Rating: Equivalent to IP65f NEMA #250 TYPE 4X/13 (Front surface at panel embedding) Feature size: All-in-one Installation configuration: Panel embedding
	Cooling Method	Natural air circulation
	Weight Approx.	AGP-35*0T: 2.5kg[5.5lb] max. (unit only) 2.7kg[5.9lb] max (DIO/FLEX NETWORK board type) AGP-3500L/3500S: 3.0kg[6.6lb] max. (unit only) 3.2kg[7.0lb] max (DIO/FLEX NETWORK board type)
	External Dimensions	AGP-35*0T: W270.5mm[10.65in] X H212.5mm[8.37in] X D57mm[2.24in] AGP-3500L/3500S: W313mm[12.32in] X H239mm[9.41in] X D56mm[2.20in]
	Panel Cut Dimensions	AGP-35*0T: W259mm[10.20in] X H201mm[7.91in]*2 AGP-3500L/3500S: W301.5mm[11.87in] X H227.5mm[8.96in]*2 Panel Thickness : 1.6mm[0.06in] to 10.0mm[0.39in]

*1 The front face of the GP unit, installed in a solid panel, has been tested using conditions equivalent to the standards shown in the specification. Even though the GP unit's level of resistance is equivalent to these standards, oils that should have no effect on the GP can possibly harm the unit. This can occur in areas where either vaporized oils are present, or where low viscosity cutting oils are allowed to adhere to the unit for long periods of time. If the GP's front face protection sheet becomes peeled off, these conditions can lead to the ingress of oil into the GP and separate protection measures are suggested.

Also, if non-approved oils are present, it may cause deformation or corrosion of the front panel's plastic cover. Therefore, prior to installing the GP be sure to confirm the type of conditions that will be present in the GP's operating environment.

If the installation gasket is used for a long period of time, or if the unit and its gasket are removed from the panel, the original level of the protection cannot be guaranteed. To maintain the original protection level, be sure to replace the installation gasket regularly.

*2 As for dimensional tolerance everything +1/-0mm[+0.04/-0in] and R in angle are below R3[R0.12in].

4.4.2 Performance Specifications

■ Performance Specifications

		AGP-3500L/3500S	AGP-3500T/AGP-3510T	AGP-3550T/AGP-3560T
Application ^{*1}		FLASH EPROM 8MB		
Data Backup		SRAM 320K byte		
		Used lithium battery for backup memory		
Interface	Serial Interface	COM1: RS232C/RS422/RS485 Asynchronous Transmission: Data Length: 7 bit/8 bit Parity: none, Odd or Even Stop Bit: 1bit/2bit Data transmission Speed: 2400 bps to 115.2 Kbps Connector: D-SUB-9pin plug		
		COM2: RS422/RS485 Asynchronous Transmission Data Length: 7 bit/8 bit Parity: none, Odd or Even Stop Bit: 1bit/2bit Data transmission Speed: 2400 bps to 115.2 Kbps 187.5 Kbps(MPI) Connector: DSUB-9pin plug		
	Ethernet Interface	IEEE802.3u,10BASE-T/100BASE-TX Connector: modular jack connector (RJ-45)		
	Expansion Unit Interface	Expansion Unit Interface (external/internal)		
	USB Host Interface	Conforms to USB1.1.(TYPE-A conn.) x 2 Power Supply Voltage: DC5V ± 5% Output Current: 500mA(max.) Communication Distance:5m(max.)		
	Expansion Memory Interface	0.6mm pitch 80pin stacking port		
	CF Card Interface	Compact Flash CF Card Slot (TYPE-II)		
	Video Input Interface	-	NTSC: 59.9Hz PAL: 50Hz Connector: RCA 75Ω	
	Sound Input Interface	-	MIC input/LINE input (Change with S/W) Connector: MINI-JACK φ3.5	
	Sound Output Interface	Speaker Output 70mW(Rated Load: 8Ω, Frequency: 1KHz) Connector: Two piece type terminal block		
	AUX Input/ Output Interface	Alarm Output, RUN Output, Buzzer Output Rated Voltage: DC24V Rated Current: 50mA		
		Remote Reset Input Input Voltage: DC24V Input Current: 6mA Operating Voltage: (When ON) Min.: DC9V, (When OFF) Max. DC2.5V Two piece type terminal block		
	Clock Accuracy ^{*2}		±65 seconds/ month (at room temperature)	

Control Memory	Variable Area	64 KB SRAM (uses lithium battery)
	Program Area	132 KB FLASH EPROM

- *1 It is user active capacity.
- *2 The GP's internal clock has a slight error. At normal operating temperatures and conditions, with the GP operating from its lithium battery, the degree of error is 65 seconds per month. Variations in operating conditions and battery life can cause this error to vary from -380 to +90 seconds per month. For systems where this degree of error will be a problem, the user should be sure to monitor this error and make adjustments when required.

NOTE

- When the message “RAAA051 Low battery” is displayed, supply power to the display unit and fully charge the battery. The battery charges within 24 hours to a level which allows backup operation. Completing a full charge requires about 96 hours (4 days).
- A Lithium battery’s lifetime is: 10 years when the battery’s ambient temperature is 40°C or less. 4.1 years when the battery’s ambient temperature is 50°C or less. 1.5 years when the battery’s ambient temperature is 60°C or less.
 When used for backup:
 Approximately 100 days, with a fully charged battery.
 Approximately 6 days, with a half-charged battery.
- 1:1 connections using a cross cable may not be possible depending on the type of personal computer and network card you are using.
 Make sure to use a hub for the Ethernet Communication.

■ Display Specifications

	AGP-3500L	AGP-3500S	AGP-3500T AGP-3550T	AGP-3510T AGP-3560T
Display Type	Monochrome LCD	STN Color LCD	TFT Color LCD	
Resolution	W640 X H480 pixels			W800 X H600 pixels
Dot pitch	W0.33mm[0.01in] X H0.33mm[0.01in]			W0.264mm[0.01in] X H0.264mm[0.01in]
Effective Display Area	W216.0mm[8.5in] X H160.8mm[6.33in]	W215.2mm[8.43in] X H162.3mm[6.39in]	W211.2mm[8.31in] X H158.4mm[6.24in]	
Color/Shade level	Black and White (16 Shades)	4,096 Colors	65,536 Colors(No blink) 16,384 Colors(Enables blink feature)	
Backlight	CCFL (Not user replaceable. When replacement is required, contact your local GP distributor.)	CCFL	CCFL	
Brightness control	8 levels of adjustment available via touch panel			
Contrast Adjustment	8 levels of adjustment available via touch panel		Not applicable	
Display Service Life	MTBF value: 50, 000hrs. or more (Backlight display service life is not included.)			
Backlight Service Life	50,000hrs. or more (at 25°C and continuous operation - period until backlight brightness decreases to 50% or backlight starts to flicker)			
Language Fonts	Japanese: 6962 (JIS Standards 1 & 2)(including 607 non-kanji characters) ANK: 158 (Korean fonts, Simplified Chinese and Taiwanese traditional Chinese fonts are downloadable.			
Text composition	Character Sizes	Standard font: 8X8, 8X16, 16X16 and 32X32 dot fonts Stroke font: 6 to 127dot fonts		
	Font Sizes	Standard font: Width can be expanded up to 8 times. Height can be expanded up to 8 times ^{*1}		
Text	8 X 8 dots	80 Char. X 60 rows		100 Char. X 75 rows
	8 X 16 dots	80 Char. X 30 rows		100 Char. X 37 rows
	16 X 16 dots	40 Char. X 30 rows		50 Char. X 37 rows
	32 X 32 dots	20 Char. X 15 rows		25 Char. X 18 rows

*1 The other font sizes can be set up by software.

■ Touch Panel Specifications

Type	Resistive Film (analog)
Resolution	1024 X 1024
Service Life	1,000,000 times or more

4.4.3 Interface Specifications

This section describes the specifications of each interface of the GP Series unit.

- IMPORTANT**
- The GP unit's serial interface is not isolated. When the host (PLC) unit is also not isolated, be sure to connect the Pin #5 SG (Signal Ground) terminal to reduce the risk of damaging the RS232C/RS422/RS485 circuit.
 - When connecting an external device to the GP using the SG terminal, be sure to check that no short-circuit loop is created when you setup the system.

- NOTE**
- When isolation is necessary, you can use either RS232C isolation unit (CA3-ISO232-01) on COM1 or RS485 isolation unit (CA3-ISO485-01) on COM2.

Serial Interfaces

Serial Interface (COM1)

This interface is used to connect an RS232C/RS422/RS485 serial cable. A D-sub 9-pin socket connector is used.

Communication method is switched via software

<GP unit side>

GP Connector	XM2C-0942-502L <OMRON Co.>
--------------	----------------------------

<Cable side>

Recommended Cable Connector	XM2D-0901 <OMRON Co.>
Recommended Cable Cover	XM2S-0913 <OMRON Co.>
Recommended Jack Screw	XM2Z-0073 <OMRON Co.>
Interfit Bracket	#4-40 inch screws are used.

In the case of RS232C

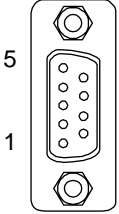
Pin Arrangement	Pin No.	RS232C		
		Signal Name	Direction	Meaning
 <p>(GP unit side)</p>	1	CD	Input	Carrier Detect
	2	RD(RXD)	Input	Receive Data
	3	SD(TXD)	Output	Send Data
	4	ER(DTR)	Output	Data Terminal Ready
	5	SG	-	Signal Ground
	6	DR(DSR)	Input	Data Set Ready
	7	RS(RTS)	Output	Request to Send
	8	CS(CTS)	Input	Send Possible
	9	CI(RI)/VCC	Input/-	Called status display +5V±5% Output 0.25A *1
	Shell	FG	-	Frame Ground (Common with SG)

*1 The RI/VCC selection for Pin #9 is switched via software. The VCC output is not protected against overcurrent. To prevent damage or a unit malfunction, use only the rated current.

In the case of RS422/RS485

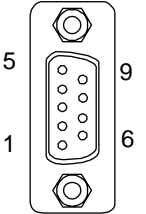
Pin Arrangement	Pin No.	RS422/RS485		
		Signal Name	Direction	Meaning
 (GP unit side)	1	RDA	Input	Receive Data A(+)
	2	RDB	Input	Receive Data B(-)
	3	SDA	Output	Send Data A(+)
	4	ERA	Output	Data Terminal Ready A(+)
	5	SG	-	Signal Ground
	6	CSB	Input	Send Possible B(-)
	7	SDB	Output	Send Data B(-)
	8	CSA	Input	Send Possible A(+)
	9	ERB	Output	Data Terminal Ready B(-)
	Shell	FG	-	Frame Ground (Common with SG)

◆Serial Interface (COM2)

This interface is used to connect an RS422/RS485 serial cable. A D-sub 9-pin plug connector is used.

<GP unit side>

GP Connector	XM3B-0942-502LX <OMRON Co.>
--------------	-----------------------------

<Cable side>

Recommended Cable Connector	XM2A-0901 <OMRON Co.>
Recommended Cable Cover	XM2S-0913 <OMRON Co.>
Recommended Jack Screw	XM2Z-0073 <OMRON Co.>
Interfit Bracket	#4-40 inch screws are used.

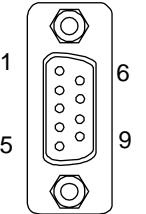
Pin Arrangement	Pin No.	RS422/RS485		
		Signal Name	Direction	Meaning
 (GP unit side)	1	TRMRX	-	Termination (Receiver side: 100Ω)
	2	RDA	Input	Receive Data A(+)
	3	SDA	Output	Send Data A(+)
	4	RS(RTS)	Output	Request for Send
	5	SG	-	Signal Ground
	6	VCC	-	+5V±5% Output 0.25A *1
	7	RDB	Input	Receive DataB(-)
	8	SDB	Output	Send Data B(-)
	9	TRMTX	-	Termination (Receiver side: 100Ω)
	Shell	FG	-	Frame Ground (Common with SG)

*1 The VCC output for Pin #6 is not protected against overcurrent. To prevent damage or a unit malfunction, use only the rated current.

■ Sound Output/AUX Input/Output Interface

This interface is used for external reset, alarm output, buzzer output or sound output.

<Cable side>

Applicable Connector	AGP-35*0T:	S2L3.5/12/90F <made by Weidmuller>
	AGP-3500L/AGP-3500S:	S2L3.5/12/180F <made by Weidmuller>

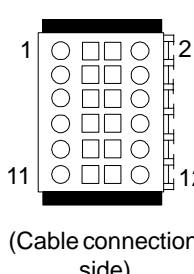
Pin Arrangement	Pin#	Signal Name	Direction	Meaning
 (Cable connection side)	1	RESET IN_A	Input	External Reset Input
	2	RESET IN_B	Input	
	3	RUN+	Output	RUN Signal
	4	RUN-	Output	
	5	ALARM+	Output	ALARM Signal
	6	ALARM-	Output	
	7	BUZZER+	Output	Buzzer Signal
	8	BUZZER-	Output	
	9	NC	-	Not Connected
	10	NC	-	Not Connected
	11	SP	Output	Speaker Out
	12	SP_GND	Output	Speaker Ground

• Input Circuit

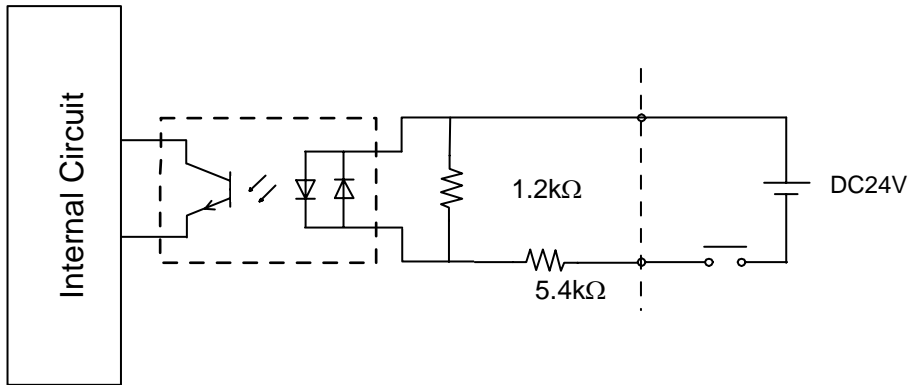

• Output Circuit

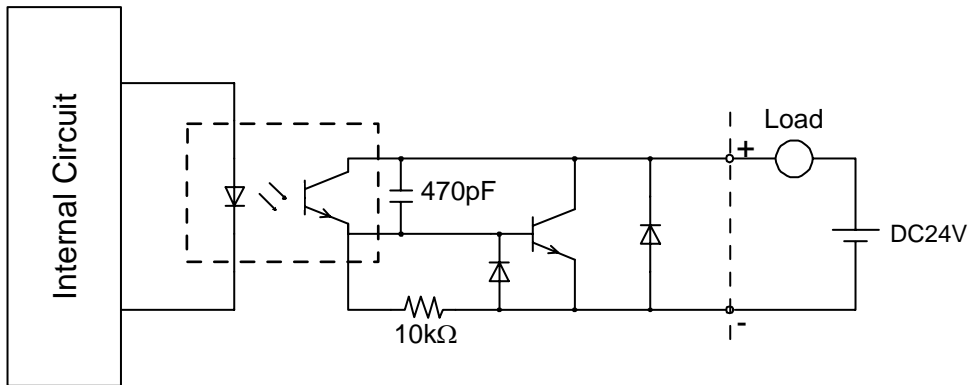

4.4.4 Dimensions

The following dimensions apply to all GP-3500 Series units.

■ External Dimensions

◆ AGP-35*0T

Unit: mm[in.]

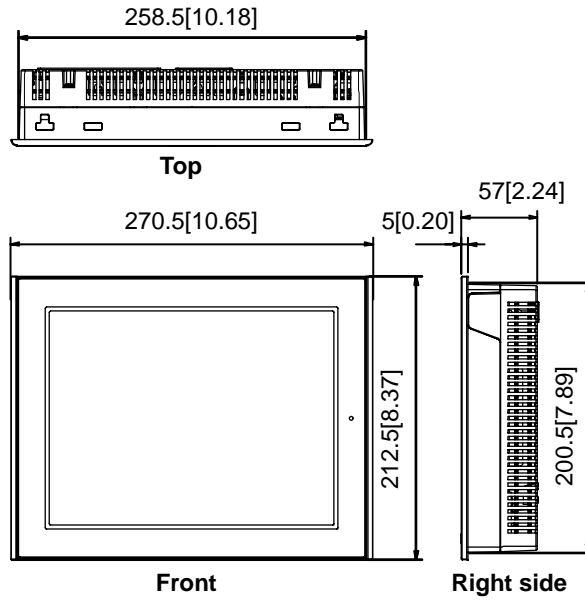

◆ AGP-3500L/AGP-3500S

Unit: mm[in.]

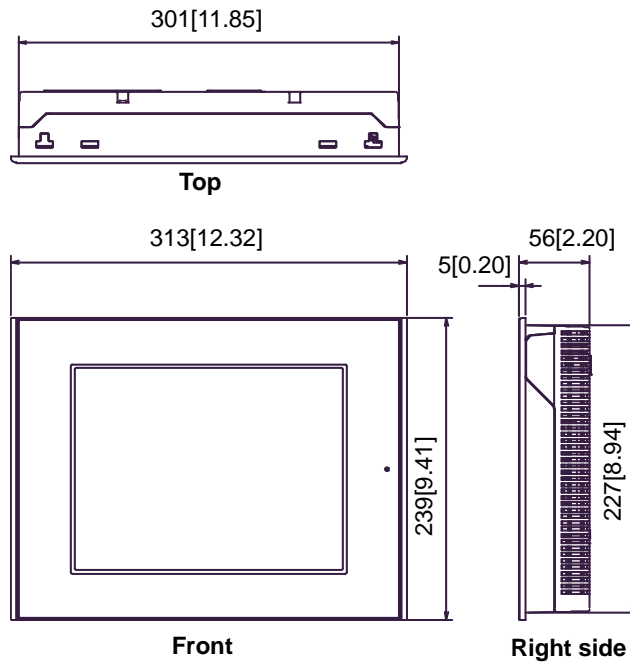

■ Installation Fasteners Attached Dimensions

◆ AGP-35*0T

Unit: mm[in.]

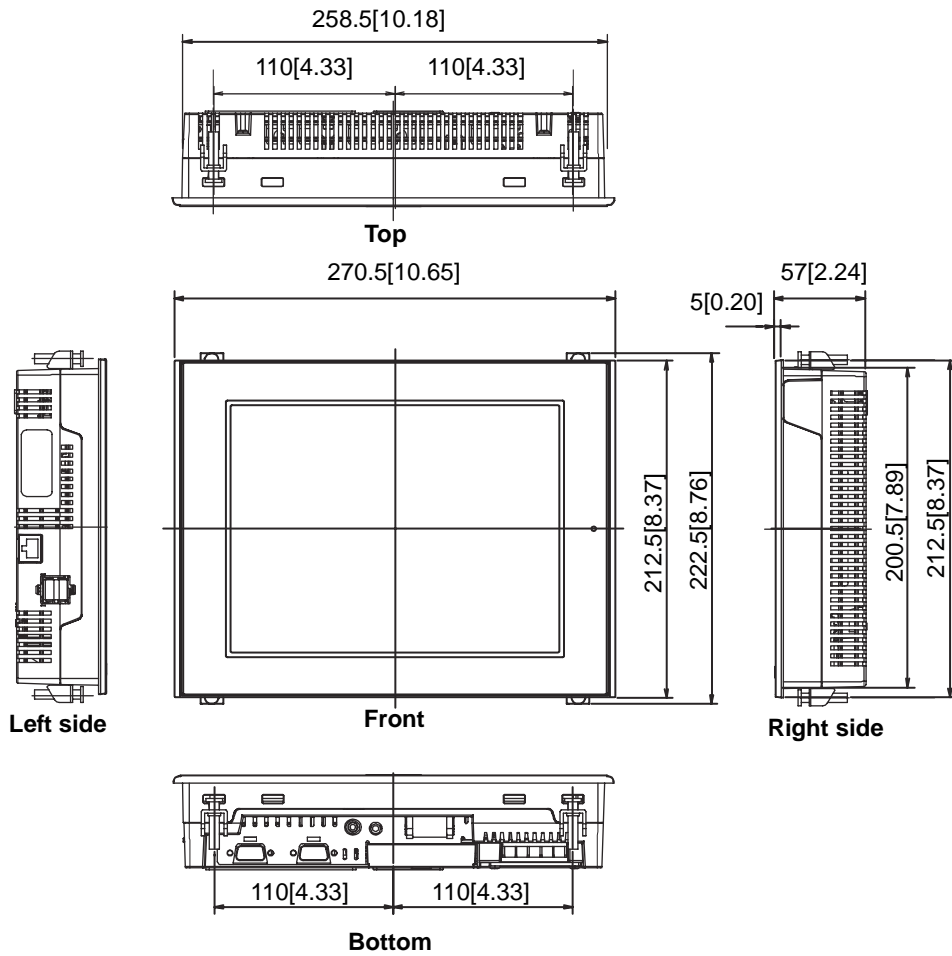

◆ AGP-3500L/AGP-3500S

Unit: mm[in.]

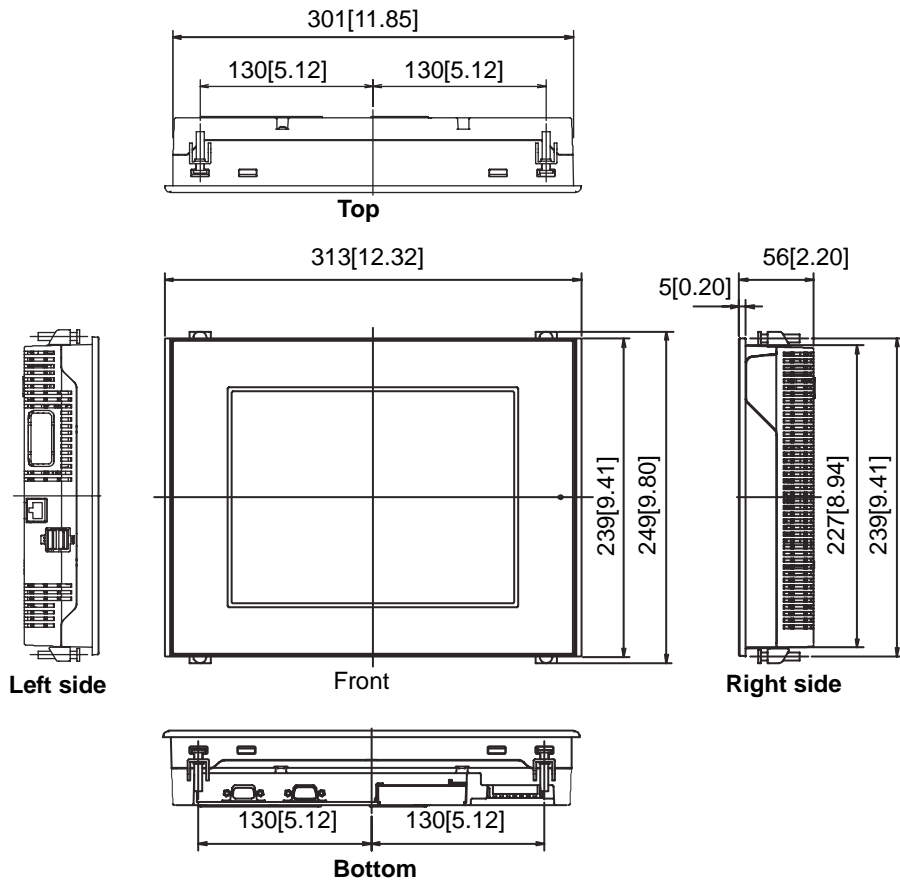

■ Cable Attached Dimensions

◆ AGP-35*0T

Unit:mm[in.]

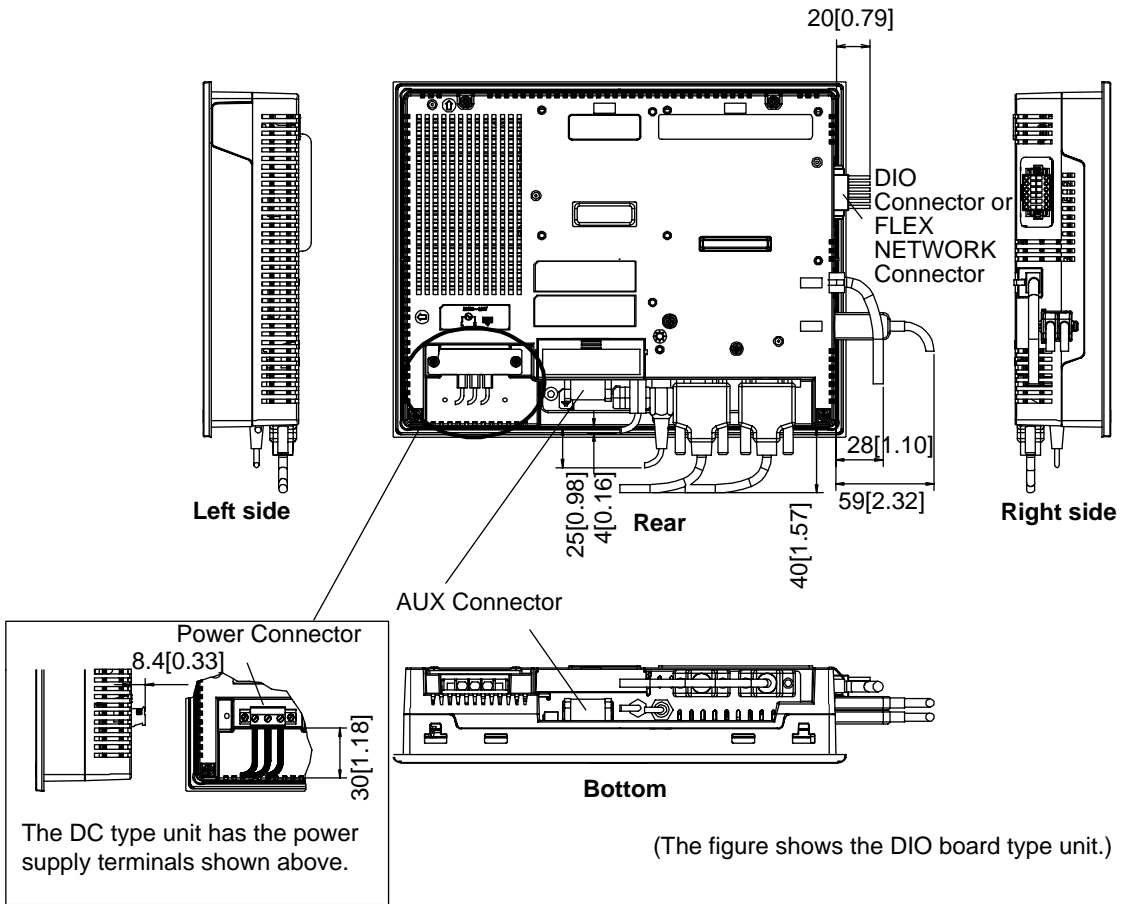

IMPORTANT

- All the above values are designed in case of cable bending. The dimensions given here are representative values depending on the type of connection cable used. Therefore, they are all intended for reference only.

◆ AGP-3500L/AGP-3500S

Unit:mm[in.]

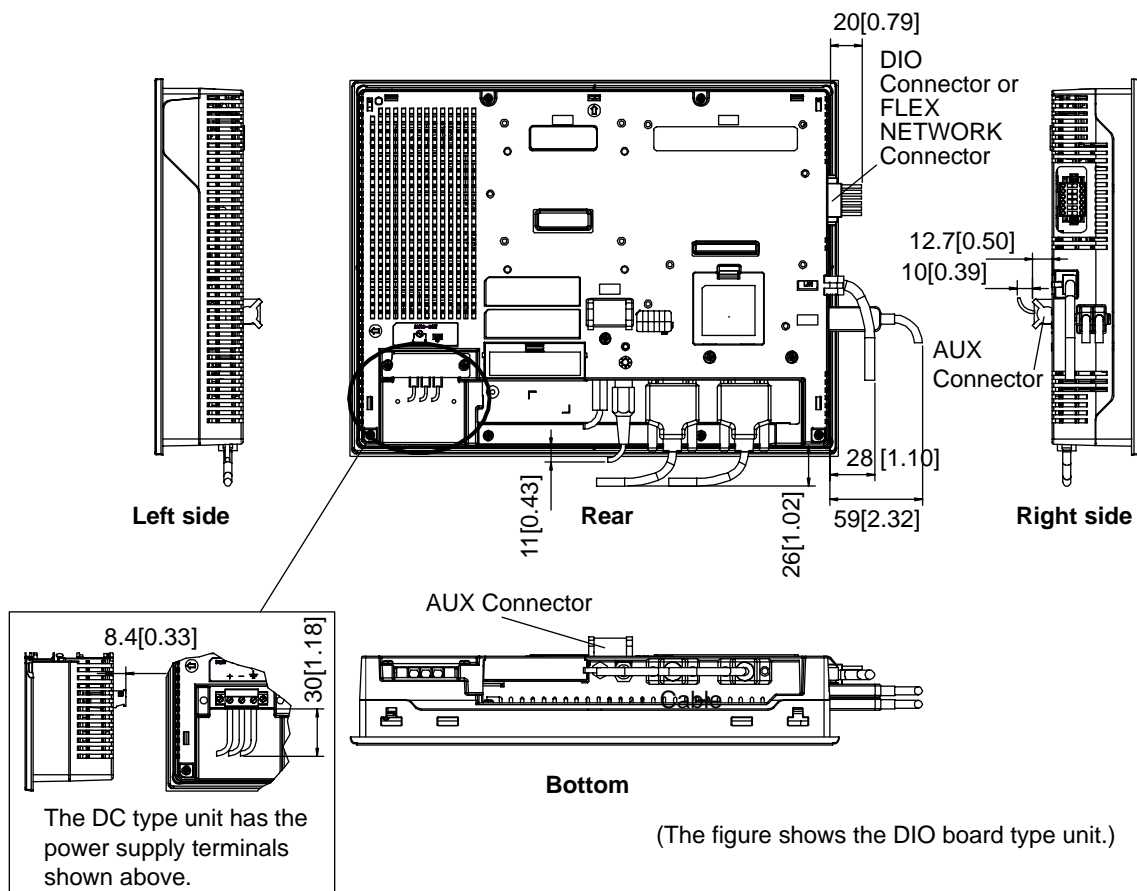
**IMPORTANT**

- Depending on the type of connection cable used the dimensions shown above will change. The dimensions given here are representative values and are intended for reference only.

■ Panel Cut Dimensions

◆ AGP-35*0T

Unit: mm[in.]

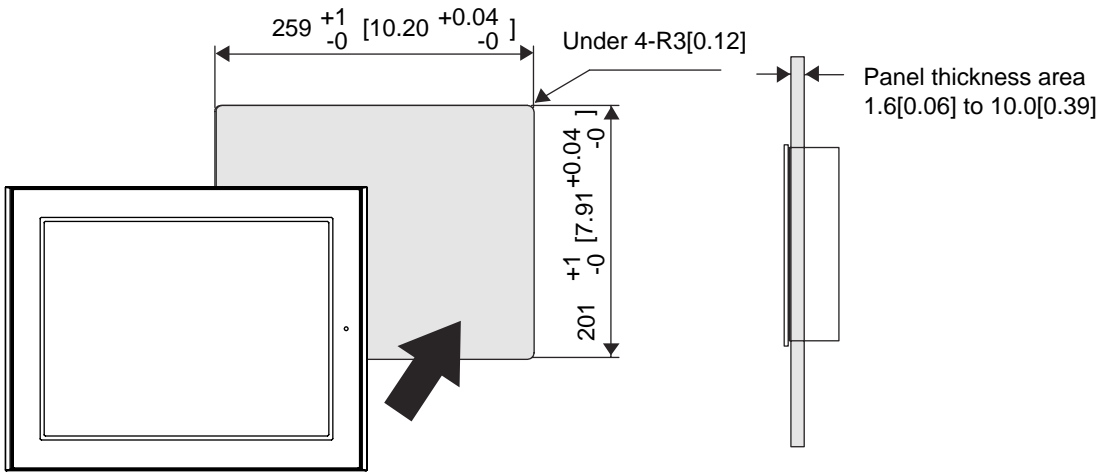

◆ AGP-3500L/AGP-3500S

Unit: mm[in.]

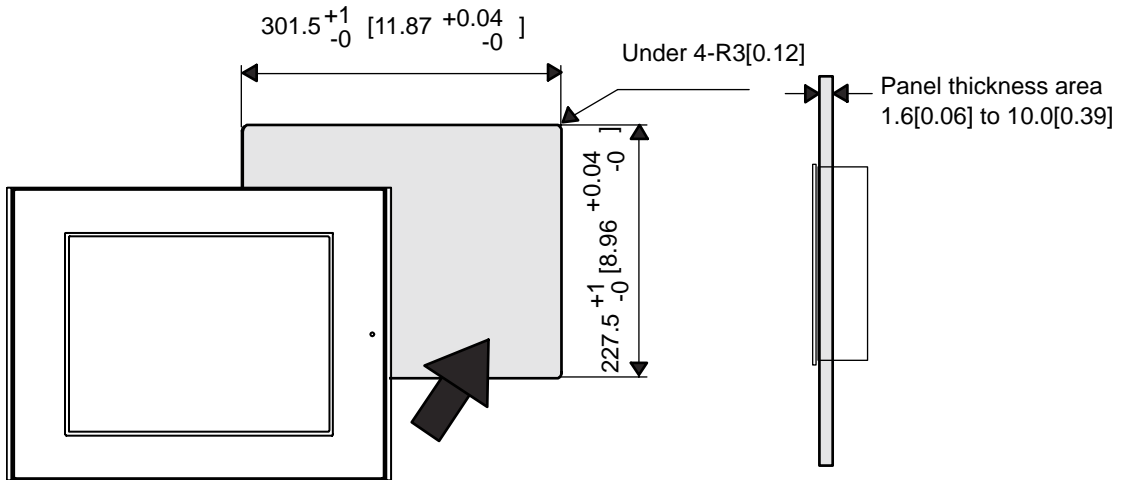

■ Installation Fasteners

Unit: mm[in.]

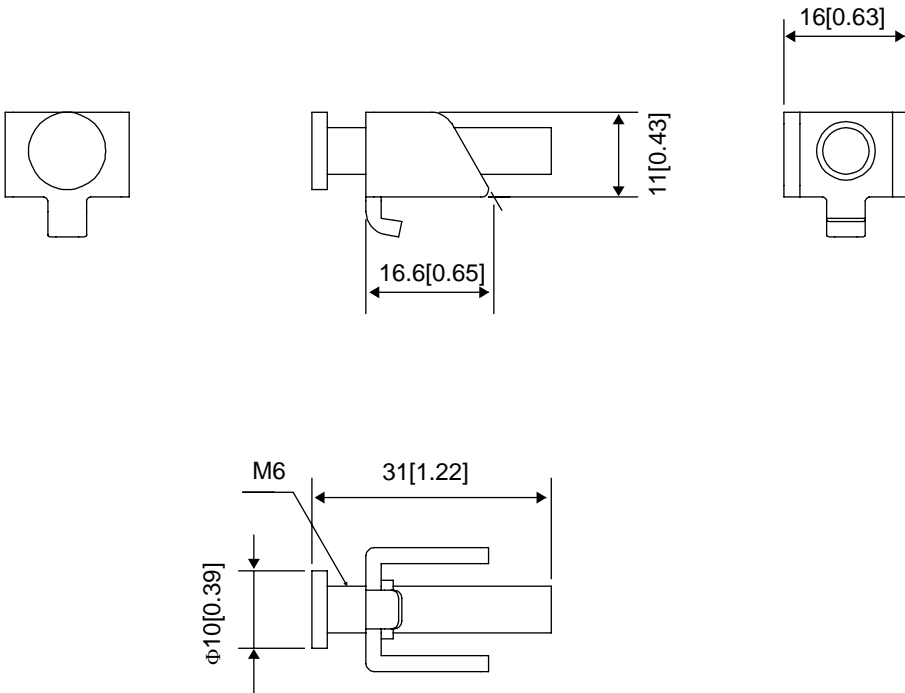

4.5 GP-3600 Series

4.5.1 General Specifications

■Electrical Specifications

		DC model	AC model
Power Supply	Input Voltage	DC24V	AC100 to 240V
	Rated Voltage	DC19.2 to 28.8V	AC85 to 265V
	Rated frequency	-	50/60Hz
	Rated frequency range	-	40 to 72Hz
	Allowable Voltage	10ms or less	Shorter than 1cycle (Voltage drop interval must be 1s or more.)
	Power Consumption	DC24V 2.08A or less (TYP 1.30A)	AC100V 0.90A or less (TYP 0.55A) AC240V 0.45A or less (TYP 0.30A)
	In-Rush Current	30A or less	60A or less
Voltage Endurance		AC1000V 20mA 1minute (between charging and FG terminals)	AC1500V 20mA 1minute (between charging and FG terminals)
Insulation Resistance		10MΩ or higher at DC500V(min.) (between charging and FG terminals)	10MΩ or higher at DC500V(min.) (between charging and FG terminals)

■ Environmental Specifications

Physical	Surrounding Air Temperature	0 to +50°C
	Storage Temperature	-20 to +60°C
	Ambient Humidity	10 to 90% RH (Wet bulb temperature: 39°C max. - no condensation.)
	Storage Humidity	10 to 90% RH (Wet bulb temperature: 39°C max. - no condensation.)
	Dust	0.1mg/m ³ and below (non-conductive levels)
	Pollution Degree	For use in Pollution Degree 2 environment
	Atmosphere	Free of corrosive gases
	Air Pressure Vibration Resistance (availment altitude)	800 to 1114hPa (2,000 meters above sea-level and below)
Mechanical	Vibration Resistance	IEC61131-2 compliant 5 to 9Hz single-amplitude 3.5mm 9 to 150Hz constant-accelerated velocity 9.8m/s ² X,Y,Z directions for 10 cycle (100 minute)
	Concussion Resistance	IEC61131-2 compliant (147m/s ² X,Y,Z directions for 3 time)
Electrical	Noise Immunity	Noise Voltage: 1000V _{P-P} (DC model) 1500V _{P-P} (AC model) Pulse Duration: 1μs Rise Time: 1ns (via noise simulator)
	Electrostatic Discharge Immunity	6kV (complies with EN 61000-4-2 Level 3)

■ Structural Specifications

Installation	Grounding	Grounding resistance of 100Ω 2mm ² or thicker wire, or your country's applicable standard. (Same for FG and SG terminals)
	Structure* ¹	Rating: Equivalent to IP65f NEMA #250 TYPE 4X/13 (Front surface at panel embedding) Feature size: All-in-one Installation configuration: Panel embedding
	Cooling Method	Natural air circulation
	Weight Approx.	3.0kg [6.6lb]max. (unit only) 3.2kg[7.0lb] max (DIO/FLEX NETWORK board type)
	External Dimensions	W313mm[12.32in] X H239mm[9.41in] X D56mm[2.20in]
	Panel Cut Dimensions	W301.5mm[11.87in] X H227.5mm[8.96in] ^{*2} Panel Thickness : 1.6mm[0.06in] to 10.0mm[0.39in]

*1 The front face of the GP unit, installed in a solid panel, has been tested using conditions equivalent to the standards shown in the specification. Even though the GP unit's level of resistance is equivalent to these standards, oils that should have no effect on the GP can possibly harm the unit. This can occur in areas where either vaporized oils are present, or where low viscosity cutting oils are allowed to adhere to the unit for long periods of time. If the GP's front face protection sheet becomes peeled off, these conditions can lead to the ingress of oil into the GP and separate protection measures are suggested.

Also, if non-approved oils are present, it may cause deformation or corrosion of the front panel's plastic cover. Therefore, prior to installing the GP be sure to confirm the type of conditions that will be present in the GP's operating environment.

If the installation gasket is used for a long period of time, or if the unit and its gasket are removed from the panel, the original level of the protection cannot be guaranteed. To maintain the original protection level, be sure to replace the installation gasket regularly.

*2 As for dimensional tolerance everything +1/-0mm[+0.04/-0in] and R in angle are below R3[R0.12in].

4.5.2 Performance Specifications

■Performance Specifications

		AGP-3600T	AGP-3650T
Application *1		FLASH EPROM 8MB	
Data Backup		SRAM 320K byte	
		Used lithium battery for backup memory	
Interface	Serial Interface	COM1: RS232C/RS422/RS485 Asynchronous Transmission: Data Length: 7 bit/8 bit Parity: none, Odd or Even Stop Bit: 1bit/2bit Data transmission Speed: 2400 bps to 115.2 Kbps Connector: D-SUB-9pin plug	
		COM2: RS422/RS485 Asynchronous Transmission Data Length: 7 bit/8 bit Parity: none, Odd or Even Stop Bit: 1bit/2bit Data transmission Speed: 2400 bps to 115.2 Kbps 187.5 Kbps(MPI) Connector: DSUB-9pin plug	
	Ethernet Interface	IEEE802.3u,10BASE-T/100BASE-TX Connector: modular jack connector (RJ-45)	
	Expansion Unit Interface	Expansion Unit Interface (external/internal)	
	USB Host Interface	Conforms to USB1.1.(TYPE-A conn.) x 2 Power Supply Voltage: DC5V ± 5% Output Current: 500mA(max.) Communication Distance:5m(max.)	
	Expansion Memory Interface	0.6mm pitch 80pin stacking port	
	CF Card Interface	Compact Flash CF Card Slot (TYPE-II)	
	Video Input Interface	-	NTSC: 59.9Hz PAL: 50Hz Connector: RCA 75Ω
	Sound Input Interface	-	MIC input/LINE input (Change with S/W) Connector: MINI-JACK φ3.5
	Sound Output Interface	Speaker Output 70mW(Rated Load: 8Ω, Frequency: 1KHz) Connector: Two piece type terminal block	
AUX Input/Output Interface	Alarm Output, RUN Output, Buzzer Output Rated Voltage: DC24V Rated Current: 50mA		
	Remote Reset Input Input Voltage: DC24V Input Current: 6mA Operating Voltage: (When ON) Min.: DC9V, (When OFF) Max. DC2.5V Two piece type terminal block		
Clock Accuracy *2		±65 seconds/ month (at room temperature)	
Control Memory	Variable Area	64 KB SRAM (uses lithium battery)	
	Program Area	132 KB FLASH EPROM	

- *1 It is user active capacity.
- *2 The GP's internal clock has a slight error. At normal operating temperatures and conditions, with the GP operating from its lithium battery, the degree of error is 65 seconds per month. Variations in operating conditions and battery life can cause this error to vary from -380 to +90 seconds per month. For systems where this degree of error will be a problem, the user should be sure to monitor this error and make adjustments when required.

NOTE

- When the message “RAAA051 Low battery” is displayed, supply power to the display unit and fully charge the battery. The battery charges within 24 hours to a level which allows backup operation. Completing a full charge requires about 96 hours (4 days).
- A Lithium battery's lifetime is: 10 years when the battery's ambient temperature is 40°C or less. 4.1 years when the battery's ambient temperature is 50°C or less. 1.5 years when the battery's ambient temperature is 60°C or less.

When used for backup:

Approximately 100 days, with a fully charged battery.

Approximately 6 days, with a half-charged battery.

- 1:1 connections using a cross cable may not be possible depending on the type of personal computer and network card you are using.
Make sure to use a hub for the Ethernet Communication.

■Display Specifications

		AGP-3600T	AGP-3650T
Display Type		TFT Color LCD	
Resolution		W800 X H600 pixels	
Dot pitch		W0.3075mm[0.01in] X H0.3075mm[0.01in]	
Effective Display Area		W248mm [9.76in] X H186.5mm[7.34in]	
Color/Shade level		65,536 Colors(No blink) 16,384 Colors(Enables blink feature)	
Backlight		CCFL	
Brightness control		8 levels of adjustment available via touch panel	
Contrast Adjustment		No corresponding function	
Display Service Life		MTBF value: 50, 000hrs. or more (Backlight display service life is not included.)	
Backlight Service Life		50,000hrs. or more (at 25°C and continuous operation - period until backlight brightness decreases to 50% or backlight starts to flicker)	
Language Fonts		Japanese: 6962 (JIS Standards 1 & 2)(including 607 non-kanji characters) ANK: 158 (Korean fonts, Simplified Chinese and Taiwanese traditional Chinese fonts are downloadable.	
Text composition	Character Sizes	Standard font: 8X8, 8X16, 16X16 and 32X32 dot fonts Stroke font: 6 to 127dot fonts	
	Font Sizes	Standard font: Width can be expanded up to 8 times. Height can be expanded up to 8 times ^{*1}	
Text	8 X 8 dots	100 Char. X 75 rows	
	8 X 16 dots	100 Char. X 37 rows	
	16 X 16 dots	50 Char. X 37 rows	
	32 X 32 dots	25 Char. X 18 rows	

*1 The other font sizes can be set up by software.

■Touch Panel Specifications

Type	Resistive Film (analog)
Resolution	1024 X 1024
Service Life	1,000,000 times or more

4.5.3 Interface Specifications

This section describes the specifications of each interface of the GP Series unit.

- IMPORTANT**
- The GP unit's serial interface is not isolated. When the host (PLC) unit is also not isolated, be sure to connect the Pin #5 SG (Signal Ground) terminal to reduce the risk of damaging the RS232C/RS422/RS485 circuit.
 - When connecting an external device to the GP using the SG terminal, be sure to check that no short-circuit loop is created when you setup the system.

- NOTE**
- When isolation is necessary, you can use either RS232C isolation unit (CA3-ISO232-01) on COM1 or RS485 isolation unit (CA3-ISO485-01) on COM2.

Serial Interfaces

Serial Interface (COM1)

This interface is used to connect an RS232C/RS422/RS485 serial cable. A D-sub 9-pin socket connector is used.

Communication method is switched via software

<GP unit side>

GP Connector	XM2C-0942-502LX <OMRON Co.>
--------------	-----------------------------

<Cable side>

Recommended Cable Connector	XM2D-0901 <OMRON Co.>
Recommended Cable Cover	XM2S-0913 <OMRON Co.>
Recommended Jack Screw	XM2Z-0073 <OMRON Co.>
Interfit Bracket	#4-40 inch screws are used.

In the case of RS232C

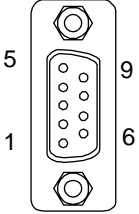
Pin Arrangement	Pin No.	RS232C		
		Signal Name	Direction	Meaning
 <p>(GP unit side)</p>	1	CD	Input	Carrier Detect
	2	RD(RXD)	Input	Receive Data
	3	SD(TXD)	Output	Send Data
	4	ER(DTR)	Output	Data Terminal Ready
	5	SG	-	Signal Ground
	6	DR(DSR)	Input	Data Set Ready
	7	RS(RTS)	Output	Request to Send
	8	CS(CTS)	Input	Send Possible
	9	CI(RI)/VCC	Input/-	Called status display +5V±5% Output 0.25A *1
	Shell	FG	-	Frame Ground (Common with SG)

*1 The RI/VCC selection for Pin #9 is switched via software. The VCC output is not protected against overcurrent. To prevent damage or a unit malfunction, use only the rated current.

In the case of RS422/RS485

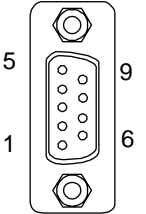
Pin Arrangement	Pin No.	RS422/RS485		
		Signal Name	Direction	Meaning
 (GP unit side)	1	RDA	Input	Receive Data A(+)
	2	RDB	Input	Receive Data B(-)
	3	SDA	Output	Send Data A(+)
	4	ERA	Output	Data Terminal Ready A(+)
	5	SG	-	Signal Ground
	6	CSB	Input	Send Possible B(-)
	7	SDB	Output	Send Data B(-)
	8	CSA	Input	Send Possible A(+)
	9	ERB	Output	Data Terminal Ready B(-)
	Shell	FG	-	Frame Ground (Common with SG)

◆Serial Interface (COM2)

This interface is used to connect an RS422/RS485 serial cable. A D-sub 9-pin plug connector is used.

<GP unit side>

GP Connector	XM3B-0942-502LX <OMRON Co.>
--------------	-----------------------------

<Cable side>

Recommended Cable Connector	XM2A-0901 <OMRON Co.>
Recommended Cable Cover	XM2S-0913 <OMRON Co.>
Recommended Jack Screw	XM2Z-0073 <OMRON Co.>
Interfit Bracket	#4-40 inch screws are used.

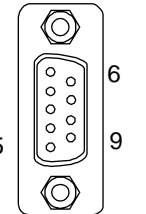
Pin Arrangement	Pin No.	RS422/RS485		
		Signal Name	Direction	Meaning
 (GP unit side)	1	TRMRX	-	Termination (Receiver side: 100Ω)
	2	RDA	Input	Receive Data A(+)
	3	SDA	Output	Send Data A(+)
	4	RS(RTS)	Output	Request for Send
	5	SG	-	Signal Ground
	6	VCC	-	+5V±5% Output 0.25A *1
	7	RDB	Input	Receive Data B(-)
	8	SDB	Output	Send Data B(-)
	9	TRMTX	-	Termination (Receiver side: 100Ω)
	Shell	FG	-	Frame Ground (Common with SG)

*1 The VCC output for Pin #6 is not protected against overcurrent. To prevent damage or a unit malfunction, use only the rated current.

■ Sound Output/AUX Input/Output Interface

This interface is used for external reset, alarm output, buzzer output or sound output.

<Cable side>

Applicable Connector	S2L3.5/12/180F <made by Weidmuller>
----------------------	-------------------------------------

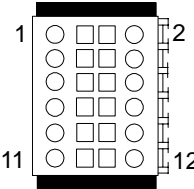
Pin Arrangement	Pin#	Signal Name	Direction	Meaning
 (Cable connection side)	1	RESET IN_A	Input	External Reset Input
	2	RESET IN_B	Input	
	3	RUN+	Output	RUN Signal
	4	RUN-	Output	
	5	ALARM+	Output	ALARM Signal
	6	ALARM-	Output	
	7	BUZZER+	Output	Buzzer Signal
	8	BUZZER-	Output	
	9	NC	-	Not Connected
	10	NC	-	Not Connected
	11	SP	Output	Speaker Out
	12	SP_GND	Output	Speaker Ground

• Input Circuit

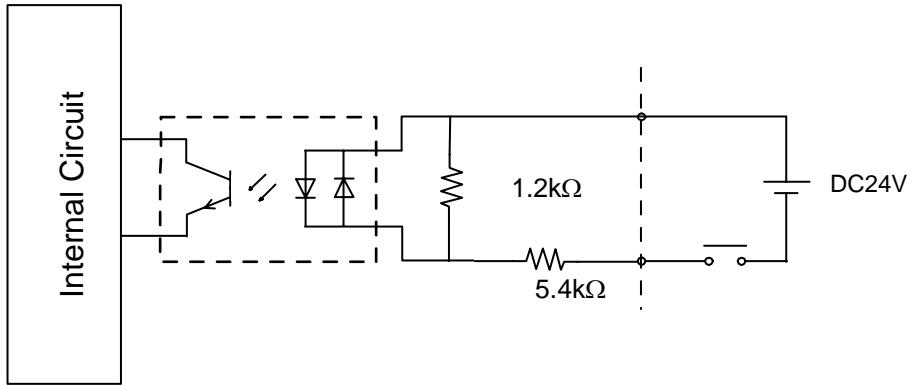

• Output Circuit

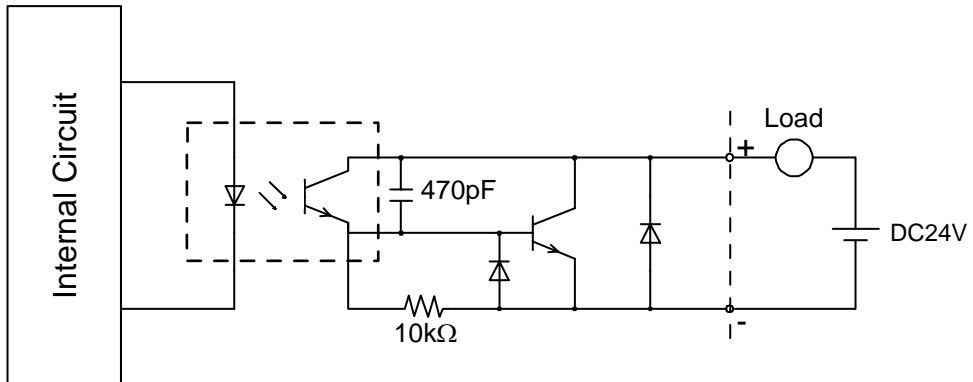

4.5.4 Dimensions

The following dimensions apply to all GP-3600 Series units.

The dimensions of the AGP-3600* are the same. The following drawings show the AGP-3650T.

■ External Dimensions

Unit: mm[in.]

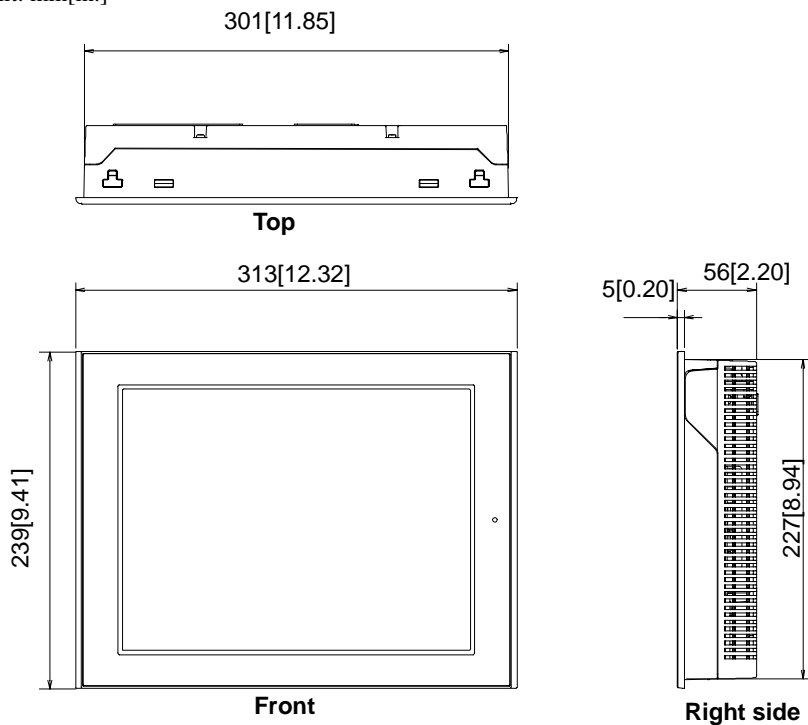

■ Installation Fasteners Attached Dimensions

Unit: mm[in.]

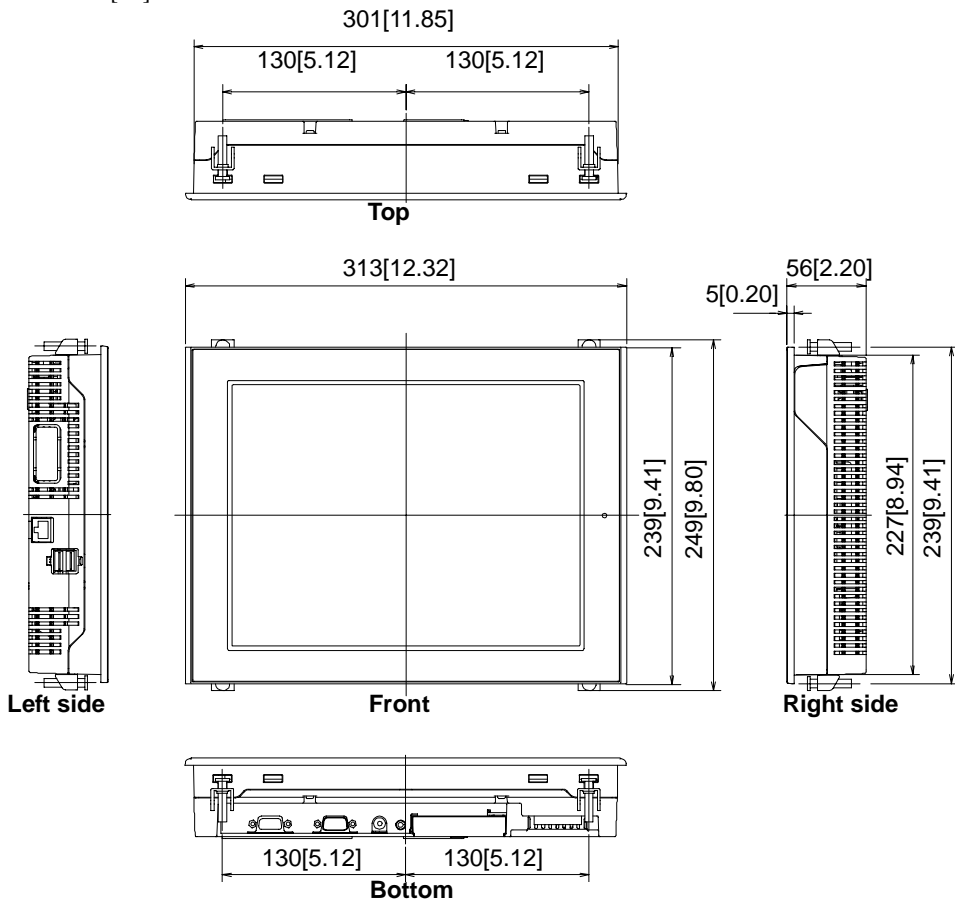

■ Cable Attached Dimensions

Unit:mm[in.]

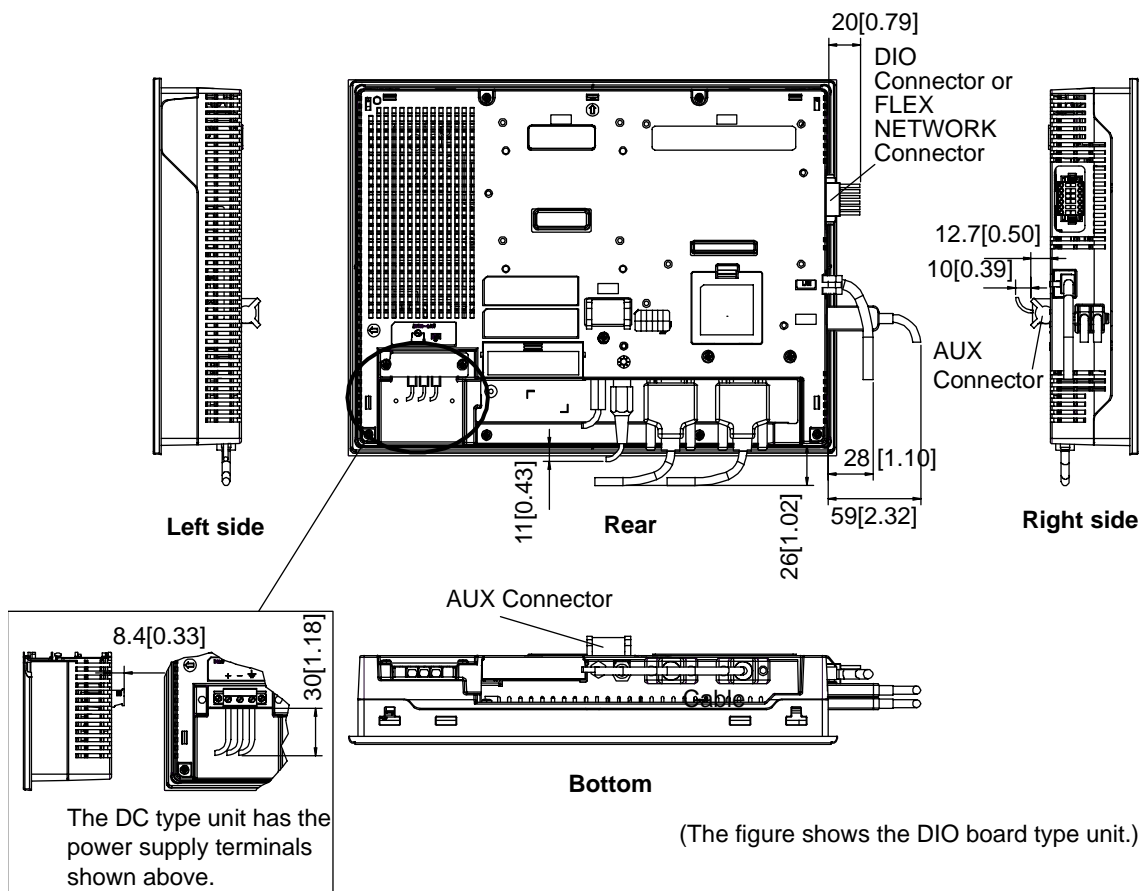

IMPORTANT

- All the above values are designed in case of cable bending. The dimensions given here are representative values depending on the type of connection cable used. Therefore, they are all intended for reference only.

■ Panel Cut Dimensions

Unit: mm[in.]

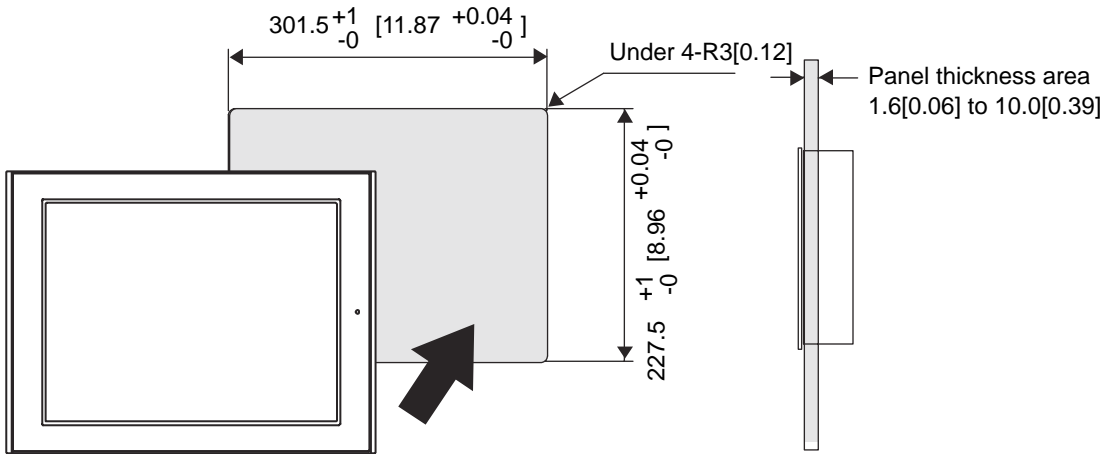

■ Installation Fasteners

Unit: mm[in.]

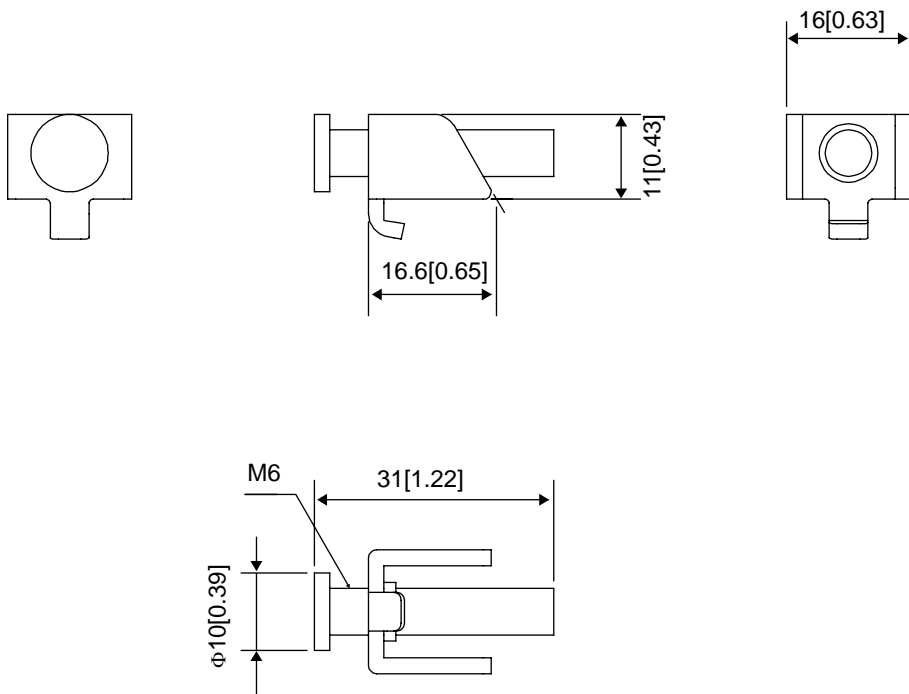

4.6 GP-3700 Series

4.6.1 General Specifications

■Electrical Specifications

		DC model	AC model
Power Supply	Input Voltage	DC24V	AC100 to 240V
	Rated Voltage	DC19.2 to 28.8V	AC85 to 265V
	Rated frequency	-	50/60Hz
	Rated frequency range	-	40 to 72Hz
	Allowable Voltage	10ms or less	Shorter than 1cycle (Voltage drop interval must be 1s or more.)
	Power Consumption	50W or less	AC100V 1.1A or less (TYP0.75A) AC240V 0.7A or less (TYP0.44A)
	In-Rush Current	30A or less	60A or less
Voltage Endurance	AC1000V 20mA 1minute (between charging and FG terminals)	AC1500V 20mA 1minute (between charging and FG terminals)	
Insulation Resistance	10MΩ or higher at DC500V(min.) (between charging and FG terminals)	10MΩ or higher at DC500V (min.) (between charging and FG terminals)	

■ Environmental Specifications

Physical	Surrounding Air Temperature	0 to +50°C
	Storage Temperature	-20 to +60°C
	Ambient Humidity	10 to 90% RH (Wet bulb temperature: 39°C max. - no condensation.)
	Storage Humidity	10 to 90% RH (Wet bulb temperature: 39°C max. - no condensation.)
	Dust	0.1mg/m ³ and below (non-conductive levels)
	Pollution Degree	For use in Pollution Degree 2 environment
	Atmosphere	Free of corrosive gases
	Air Pressure Vibration Resistance (availment altitude)	800 to 1114hPa (2,000 meters above sea-level and below)
Mechanical	Vibration Resistance	IEC61131-2 compliant 5 to 9Hz single-amplitude 3.5mm 9 to 150Hz constant-accelerated velocity 9.8m/s ² X,Y,Z directions for 10 cycle (100 minute)
	Concussion Resistance	IEC61131-2 compliant (147m/s ² X,Y,Z directions for 3 time)
Electrical	Noise Immunity	Noise Voltage: 1000V _{P-P} (DC model) 1500V _{P-P} (AC model) Pulse Duration: 1μs Rise Time: 1ns (via noise simulator)
	Electrostatic Discharge Immunity	6kV (complies with EN 61000-4-2 Level 3)

■ Structure Specifications

Installation	Grounding	Grounding resistance of 100Ω 2mm ² or thicker wire, or your country's applicable standard. (Same for FG and SG terminals)
	Structure*1	Rating: Equivalent to IP65f NEMA #250 TYPE 4X/13 (Front surface at panel embedding) Feature size: All-in-one Installation configuration: Panel embedding
	Cooling Method	Natural air circulation
	Weight Approx.	5.6kg[12.3lb]max. (unit only)
	External Dimensions	W395mm[15.55in] X H294mm[11.57in] X D60mm[2.36in]
	Panel Cut Dimensions	W383.5mm[15.10in] X H282.5mm[11.12in]*2 Panel Thickness : 1.6mm[0.06in] to 10.0mm[0.39in]

*1 The front face of the GP unit, installed in a solid panel, has been tested using conditions equivalent to the standards shown in the specification. Even though the GP unit's level of resistance is equivalent to these standards, oils that should have no effect on the GP can possibly harm the unit. This can occur in areas where either vaporized oils are present, or where low viscosity cutting oils are allowed to adhere to the unit for long periods of time. If the GP's front face protection sheet becomes peeled off, these conditions can lead to the ingress of oil into the GP and separate protection measures are suggested.

Also, if non-approved oils are present, it may cause deformation or corrosion of the front panel's plastic cover. Therefore, prior to installing the GP be sure to confirm the type of conditions that will be present in the GP's operating environment.

If the installation gasket is used for a long period of time, or if the unit and its gasket are removed from the panel, the original level of the protection cannot be guaranteed. To maintain the original protection level, be sure to replace the installation gasket regularly.

*2 As for dimensional tolerance everything $+1/-0$ mm[$+0.04/-0$ in] and R in angle are below R3[R0.12in].

4.6.2 Performance Specifications

■ Performance Specifications

		AGP-3750T	
Application ^{*1}		FLASH EPROM 8MB	
Data Backup		SRAM 320K byte	
		Used lithium battery for backup memory	
Interface	Serial Interface	COM1: RS232C/RS422/RS485 Asynchronous Transmission: Data Length: 7 bit/8 bit Parity: none, Odd or Even Stop Bit: 1bit/2bit Data transmission Speed: 2400 bps to 115.2 Kbps Connector: D-SUB-9pin plug	
		COM2: RS422/RS485 Asynchronous Transmission Data Length: 7 bit/8 bit Parity: none, Odd or Even Stop Bit: 1bit/2bit Data transmission Speed: 2400 bps to 115.2 Kbps 187.5 Kbps(MPI) Connector: DSUB-9pin plug	
	Ethernet Interface	IEEE802.3u,10BASE-T/100BASE-TX Connector: modular jack connector (RJ-45)	
	Expansion Unit Interface	Expansion Unit Interface (external/internal)	
	USB Host Interface	Conforms to USB1.1.(TYPE-A conn.) x 2 Power Supply Voltage: DC5V ± 5% Output Current: 500mA(max.) Communication Distance:5m(max.)	
	Expansion Memory Interface	0.6mm pitch 80pin stacking port	
	CF Card Interface	Compact Flash CF Card Slot (TYPE-II)	
	Video Input Interface	NTSC: 59.9Hz PAL: 50Hz Connector: RCA 75Ω	
	Sound Input Interface	MIC input/LINE input (Change with S/W) Connector: MINI-JACK Φ3.5	
	Sound Output Interface	Speaker Output 70mW(Rated Load: 8Ω, Frequency: 1KHz) Connector: Two piece type terminal block	
	AUX Input/ Output Interface	Alarm Output, RUN Output, Buzzer Output Rated Voltage: DC24V Rated Current: 50mA	
		Remote Reset Input Input Voltage: DC24V Input Current: 6mA Operating Voltage: (When ON) Min.: DC9V, (When OFF) Max. DC2.5V Two piece type terminal block	
	Clock Accuracy ^{*2}		±65 seconds/ month (at room temperature)

Control Memory	Variable Area	64 KB SRAM (uses lithium battery)
	Program Area	132 KB FLASH EPROM

- *1 It is user active capacity.
- *2 The GP's internal clock has a slight error. At normal operating temperatures and conditions, with the GP operating from its lithium battery, the degree of error is 65 seconds per month. Variations in operating conditions and battery life can cause this error to vary from -380 to +90 seconds per month. For systems where this degree of error will be a problem, the user should be sure to monitor this error and make adjustments when required.

NOTE

- When the message "RAAA051 Low battery" is displayed, supply power to the display unit and fully charge the battery. The battery charges within 24 hours to a level which allows backup operation. Completing a full charge requires about 96 hours (4 days).
- A Lithium battery's lifetime is: 10 years when the battery's ambient temperature is 40°C or less. 4.1 years when the battery's ambient temperature is 50°C or less. 1.5 years when the battery's ambient temperature is 60°C or less.

When used for backup:

Approximately 100 days, with a fully charged battery.

Approximately 6 days, with a half-charged battery.

- 1:1 connections using a cross cable may not be possible depending on the type of personal computer and network card you are using.

Make sure to use a hub for the Ethernet Communication.

■ Display Specifications

		AGP-3750T
Display Type		TFT Color LCD
Resolution		W1024 X H768 pixels
Dot pitch		W0.297mm[0.01in] X H0.297mm[0.01in]
Effective Display Area		W306.2mm[12.06in] X H230.1mm[9.06in]
Color/Shade level		65,536 Colors(No blink) 16,384 Colors(Enables blink feature)
Backlight		CCFL
Brightness control		8 levels of adjustment available via touch panel
Contrast Adjustment		No corresponding function
Display Service Life		MTBF value: 50, 000hrs. or more (Backlight display service life is not included.)
Backlight Service Life		50,000hrs. or more (at 25°C and continuous operation - period until backlight brightness decreases to 50% or backlight starts to flicker)
Language Fonts		Japanese: 6962 (JIS Standards 1 & 2)(including 607 non-kanji characters) ANK: 158 (Korean fonts, Simplified Chinese and Taiwanese traditional Chinese fonts are downloadable.
Text composition	Character Sizes	Standard font: 8X8, 8X16, 16X16 and 32X32 dot fonts Stroke font: 6 to 127dot fonts
	Font Sizes	Standard font: Width can be expanded up to 8 times. Height can be expanded up to 8 times*1
Text	8 X 8 dots	128 Char. X 96 rows
	8 X 16 dots	128 Char. X 48 rows
	16 X 16 dots	64 Char. X 48 rows
	32 X 32 dots	32 Char. X 24 rows

*1 The other font sizes can be set up by software.

■ Touch Panel Specifications

Type	Resistive Film (analog)
Resolution	1024 X 1024
Service Life	1,000,000 times or more

4.6.3 Interface Specifications

This section describes the specifications of each interface of the GP Series unit.

- IMPORTANT**
- The GP unit's serial interface is not isolated. When the host (PLC) unit is also not isolated, be sure to connect the Pin #5 SG (Signal Ground) terminal to reduce the risk of damaging the RS232C/RS422/RS485 circuit.
 - When connecting an external device to the GP using the SG terminal, be sure to check that no short-circuit loop is created when you setup the system.

- NOTE**
- When isolation is necessary, you can use either RS232C isolation unit (CA3-ISO232-01) on COM1 or RS485 isolation unit (CA3-ISO485-01) on COM2.

Serial Interfaces

Serial Interface (COM1)

This interface is used to connect an RS232C/RS422/RS485 serial cable. A D-sub 9-pin socket connector is used.

Communication method is switched via software

<GP unit side>

GP Connector	XM2C-0942-502LX <OMRON Co.>
--------------	-----------------------------

<Cable side>

Recommended Cable Connector	XM2D-0901 <OMRON Co.>
Recommended Cable Cover	XM2S-0913 <OMRON Co.>
Recommended Jack Screw	XM2Z-0073 <OMRON Co.>
Interfit Bracket	#4-40 inch screws are used.

In the case of RS232C

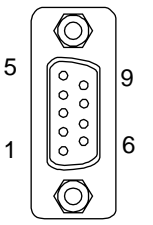
Pin Arrangement	Pin No.	RS232C		
		Signal Name	Direction	Meaning
 <p>(GP unit side)</p>	1	CD	Input	Carrier Detect
	2	RD(RXD)	Input	Receive Data
	3	SD(TXD)	Output	Send Data
	4	ER(DTR)	Output	Data Terminal Ready
	5	SG	-	Signal Ground
	6	DR(DSR)	Input	Data Set Ready
	7	RS(RTS)	Output	Request to Send
	8	CS(CTS)	Input	Send Possible
	9	CI(RI)/VCC	Input/-	Called status display +5V±5% Output 0.25A *1
	Shell	FG	-	Frame Ground (Common with SG)

*1 The RI/VCC selection for Pin #9 is switched via software. The VCC output is not protected against overcurrent. To prevent damage or a unit malfunction, use only the rated current.

In the case of RS422/RS485

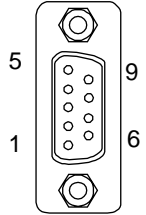
Pin Arrangement	Pin No.	RS422/RS485		
		Signal Name	Direction	Meaning
 (GP unit side)	1	RDA	Input	Receive Data A(+)
	2	RDB	Input	Receive Data B(-)
	3	SDA	Output	Send Data A(+)
	4	ERA	Output	Data Terminal Ready A(+)
	5	SG	-	Signal Ground
	6	CSB	Input	Send Possible B(-)
	7	SDB	Output	Send Data B(-)
	8	CSA	Input	Send Possible A(+)
	9	ERB	Output	Data Terminal Ready B(-)
	Shell	FG	-	Frame Ground (Common with SG)

◆Serial Interface (COM2)

This interface is used to connect an RS422/RS485 serial cable. A D-sub 9-pin plug connector is used.

<GP unit side>

GP Connector	XM3B-0942-502LX <OMRON Co.>
--------------	-----------------------------

<Cable side>

Recommended Cable Connector	XM2A-0901 <OMRON Co.>
Recommended Cable Cover	XM2S-0913 <OMRON Co.>
Recommended Jack Screw	XM2Z-0073 <OMRON Co.>
Interfit Bracket	#4-40 inch screws are used.

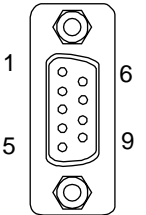
Pin Arrangement	Pin No.	RS422/RS485		
		Signal Name	Direction	Meaning
 (GP unit side)	1	TRMRX	-	Termination (Receiver side: 100Ω)
	2	RDA	Input	Receive Data A(+)
	3	SDA	Output	Send Data A(+)
	4	RS(RTS)	Output	Request for Send
	5	SG	-	Signal Ground
	6	VCC	-	+5V±5% Output 0.25A *1
	7	RDB	Input	Receive DataB(-)
	8	SDB	Output	Send Data B(-)
	9	TRMTX	-	Termination (Receiver side: 100Ω)
	Shell	FG	-	Frame Ground (Common with SG)

*1 The VCC output for Pin #6 is not protected against overcurrent. To prevent damage or a unit malfunction, use only the rated current.

■ Sound Output/AUX Input/Output Interface

This interface is used for external reset, alarm output, buzzer output or sound output

<Cable side>

Applicable Connector	S2L3.5/12/180F <made by Weidmuller>
----------------------	-------------------------------------

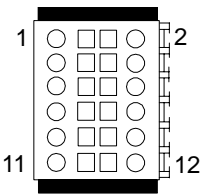
Pin Arrangement	Pin#	Signal Name	Direction	Meaning
 <p>(Cable connection side)</p>	1	RESET IN_A	Input	External Reset Input
	2	RESET IN_B	Input	
	3	RUN+	Output	RUN Signal
	4	RUN-	Output	
	5	ALARM+	Output	ALARM Signal
	6	ALARM-	Output	
	7	BUZZER+	Output	Buzzer Signal
	8	BUZZER-	Output	
	9	NC	-	Not Connected
	10	NC	-	Not Connected
	11	SP	Output	Speaker Out
	12	SP_GND	Output	Speaker Ground

• Input Circuit

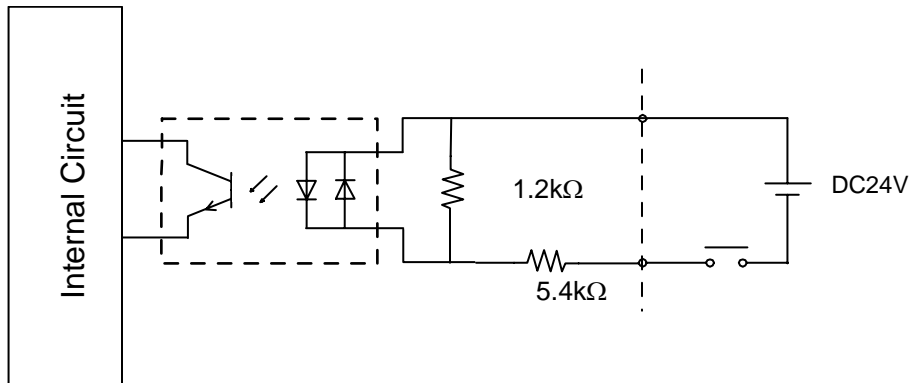

• Output Circuit

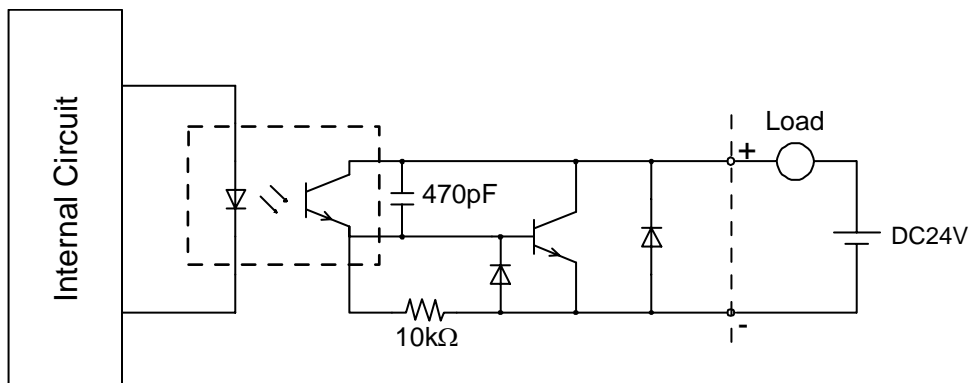

4.6.4 Dimensions

The following dimensions apply to all GP-3700 Series units.

The following drawings show the AGP-3750T.

■ External Dimensions

Unit: mm[in.]

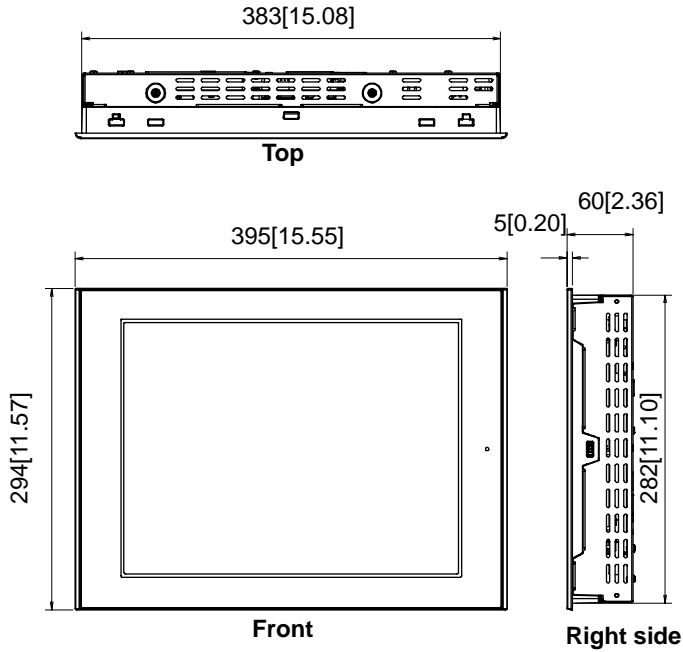

■ Installation Fasteners Attached Dimensions

Unit: mm[in.]

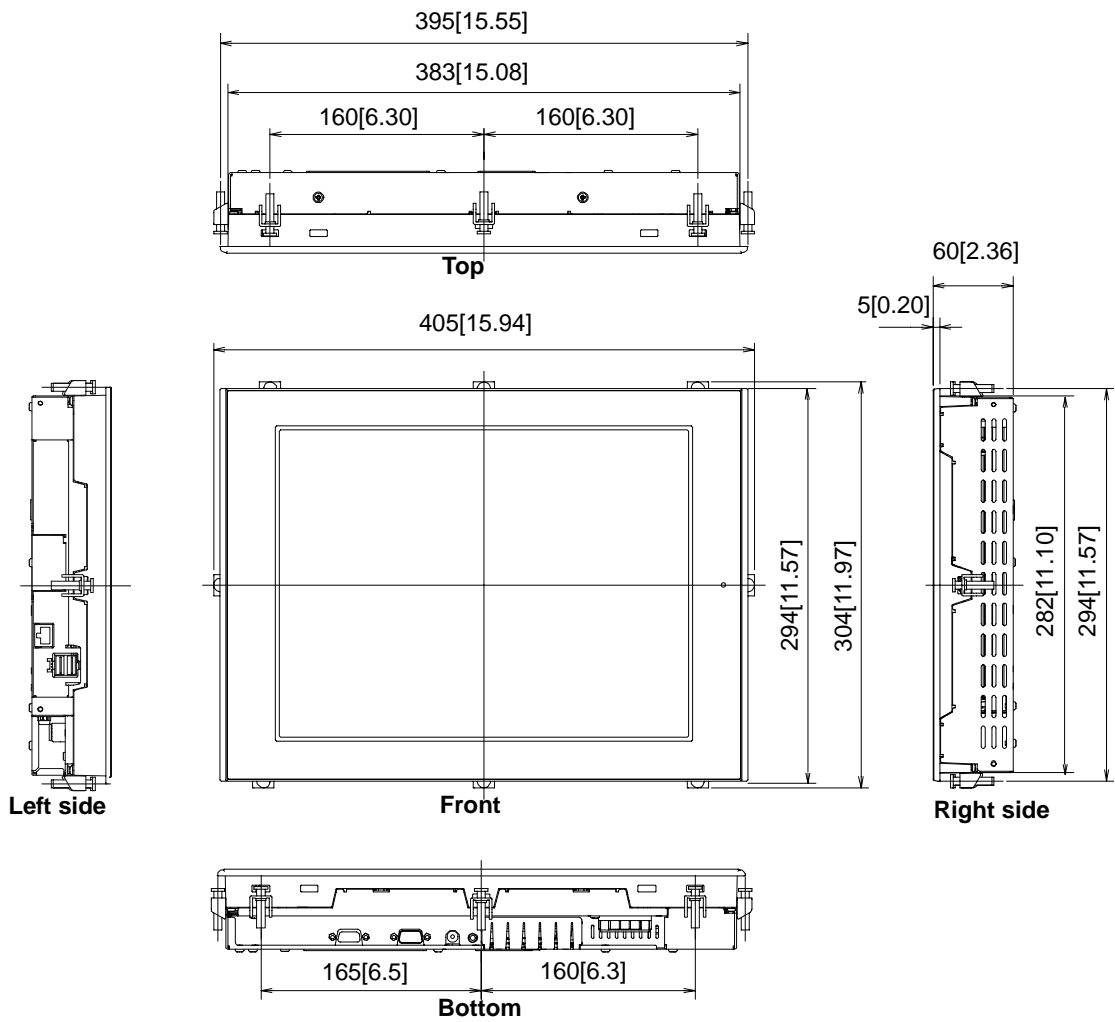

■ Cable Attached Dimensions

Unit: mm[in.]

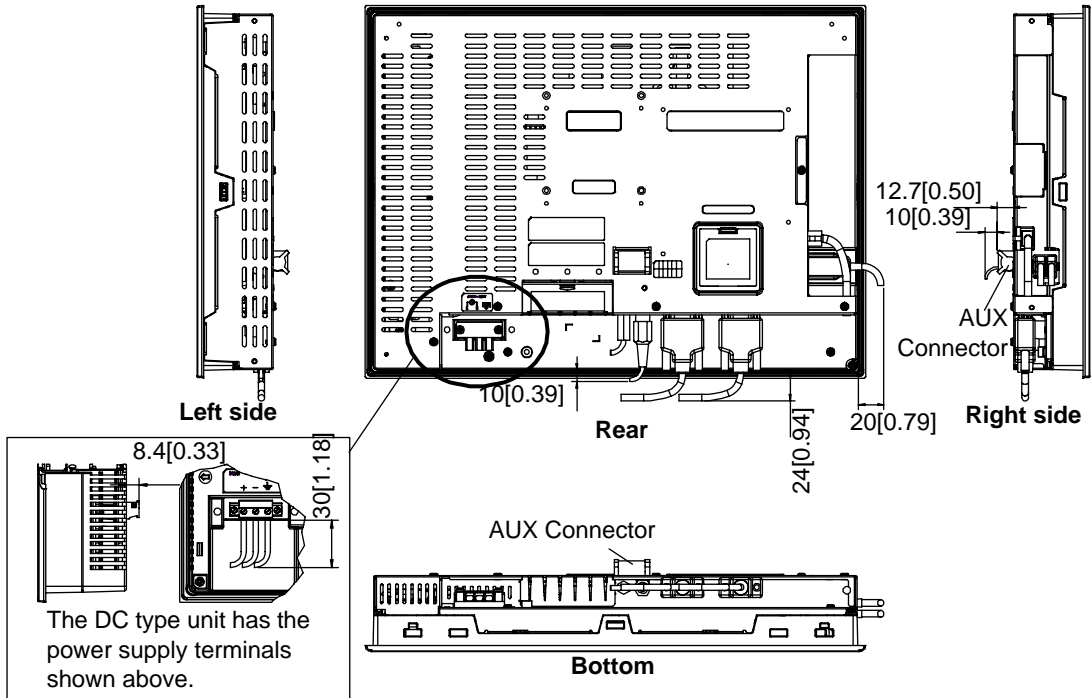

IMPORTANT

- All the above values are designed in case of cable bending. The dimensions given here are representative values depending on the type of connection cable used. Therefore, they are all intended for reference only.

■ Panel Cut Dimensions

Unit: mm[in.]

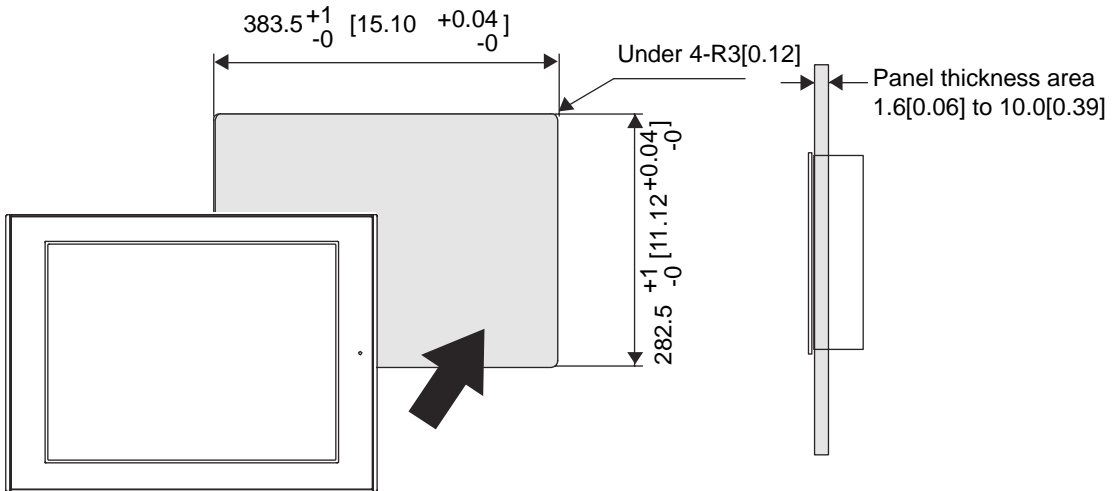

■ Installation Fasteners

Unit: mm[in.]

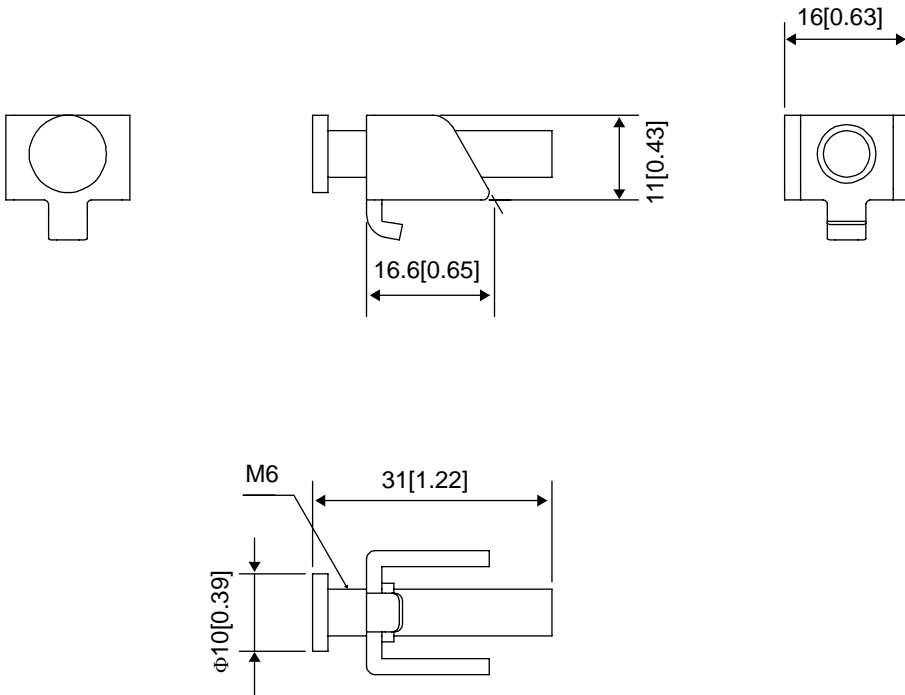

5



DIO Connector

1. DIO Interface (Connector)
2. Wiring to the DIO Connector

This section explains the interface specifications of the DIO board type unit (model with DIO I/F) and the wiring to the DIO Connector.

This section describes the DIO Connector packaged with the DIO board type unit of the GP3000 series.

This connector is an accessory of the GP unit. It is also offered as an optional maintenance item by Digital Electronics Corporation.

SEE → 2.2 Optional Item for the DIO Board Type (page 2-6)

NOTE • When you use the DIO board type unit of the GP3000 series, read this section in conjunction with the specifications of your GP series (Chapter 4).

5.1 DIO Interface (Connector)

This interface is used to connect an external I/O device.

IMPORTANT • When preparing the cable to connect the wiring, check the pin numbers inscribed on the DIO Connector.

Recommended connector	1-1871940-6 <Tyco Electronics AMP.>
-----------------------	-------------------------------------

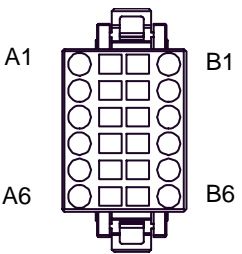
Pin Arrangement	Pin No.	Signal Name	Pin No.	Signal Name
 <p>(Cable connection side)</p>	A1	0V	B1	+24V
	A2	OUT1	B2	OUT0
	A3	NC	B3	COM
	A4	IN5	B4	IN4
	A5	IN3	B5	IN2
	A6	IN1	B6	IN0

■ Input Specifications

Rated Voltage	DC 24V
Maximum Allowable Voltage	DC 28.8V
Input Method	Source/Sink Input
Rated Current	5.7 mA (DC 24V)
Input Resistance	4.2 kΩ
Operation Range	ON Voltage: DC 15V or more
	OFF Voltage: DC 5V or less
Input Delay Time	OFF to ON: 1.5 ms or less
	ON to OFF: 1.5 ms or less
Common Lines	1
Common Design	6 points/1 common line
External Connection	12-pin connector (used with Output section)
Input Points	6
Input Signal Display	No LED indicators
Status Display	None
Isolation Method	Photocoupler Isolation
External Power Supply	For Signal: DC 24V

◆ Input Circuit

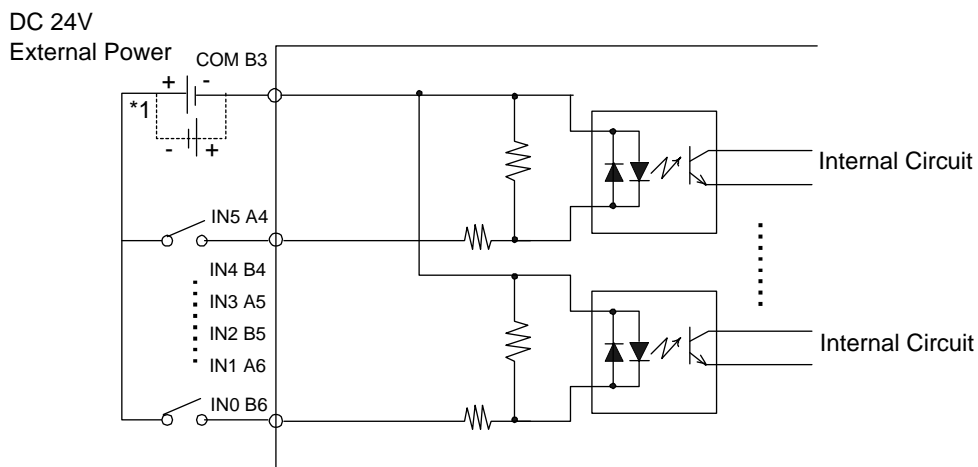

*1 Dotted line shows connection to sink output type.

■ Output Specifications (Sink type)

Rated Voltage	DC 24V
Rated Voltage Range	DC 20.4V to DC 28.8V
Output Method	Sink Output
Maximum Load Voltage	0.2A /point, 0.4A /common
Output Voltage Drop	1.5V or less
Output Delay Time	OFF to ON: 1ms or less
	ON to OFF: 1 ms or less
Voltage Leakage (when OFF)	0.1mA or less
Clamp Voltage	39V ±1V
Type of Output	Transistor Output
Common Lines	1
Common Design	2 points/1 common line
External Connection	12-pin connector (also used for Input)
Output Protection Type	Output is unprotected
Internal Fuse	1.5A, 125V DIP fuse (not replaceable)
Surge Control Circuit	Zener diode
Output Points	2
Output Signal Display	No LED indicators
Status Display Element	None
Isolation Method	Photocoupler Isolation
External Power Supply	DC 24V

◆ Output Circuit (Sink type)

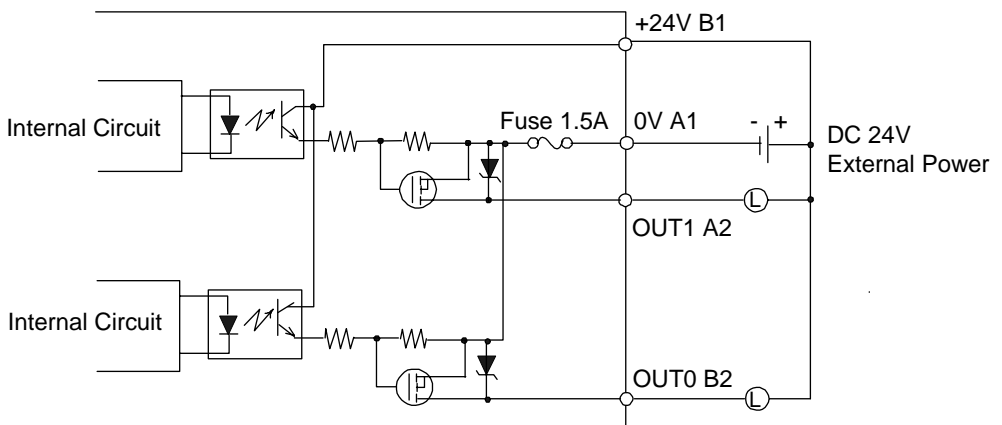

NOTE

- Since the output terminals are not electrically protected, an output line might be short-circuited or a connection fault might damage the GP unit. Please install an applicable fuse to prevent an overload in the circuit, if necessary.

■ Output Specifications (Source type)

Rated Voltage	DC 24V
Rated Voltage Range	DC 20.4V to DC 28.8V
Output Method	Source Output
Maximum Load Voltage	0.2A /point, 0.4A /common
Output Voltage Drop	DC 1.5V or less
Output Delay Time	OFF to ON: 1ms or less
	ON to OFF: 1 ms or less
Voltage Leakage (when OFF)	0.1mA or less
Clamp Voltage	39V ±1V
Type of Output	Transistor Output
Common Lines	1
Common Design	2 points/1 common line
External Connection	12-pin connector (also used for Input)
Output Protection Type	Output is unprotected
Internal Fuse	1.5A, 125V DIP fuse (not replaceable)
Surge Control Circuit	Zener diode
Output Points	2
Output Signal Display	No LED indicators
Status Display Element	None
Isolation Method	Photocoupler Isolation
External Power Supply	DC 24V

◆ Output Circuit (Source type)

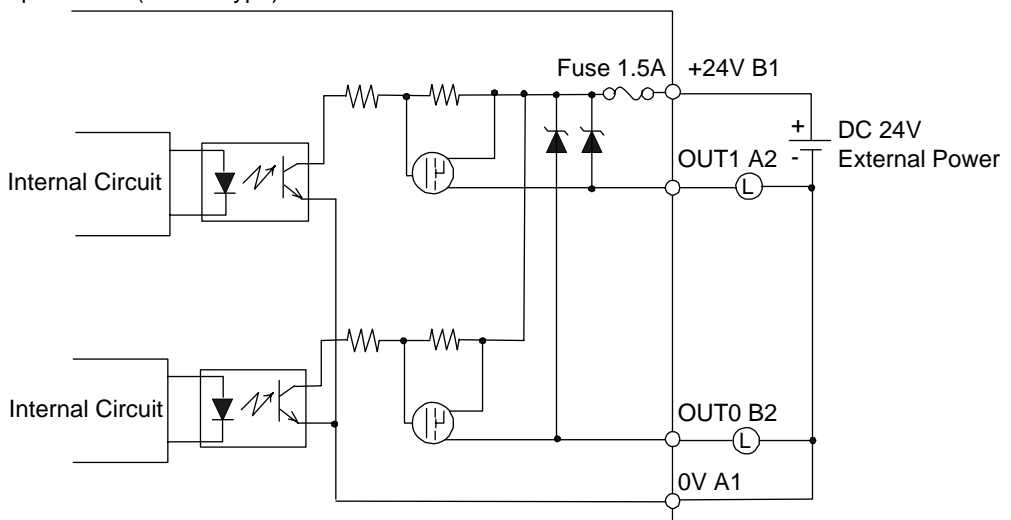

NOTE

- Since the output terminals are not electrically protected, an output line might be short-circuited or a connection fault might damage the GP unit. Please install an applicable fuse to prevent an overload in the circuit, if necessary.

5.2 Wiring to the DIO Connector

⚠ WARNING

❗ Be sure to remove the DIO Connector from the GP unit prior to starting wiring. Failure to do so may cause an electric shock.

◆ Items Required to Wire Connectors

- Screwdriver

Recommended type: 1891348-1 <Tyco Electronics AMP.>

If another manufacturer is used, be sure the part has the following dimensions:

point depth: 1.5mm [0.06in.]

point height: 2.4mm [0.09in.]

Point shape should be DIN5264A, and meet Security Standard DN EN60900.

Also, the screwdriver's tip should be flat as indicated in order to access the narrow hole of the connector:



The connectors are a spring clamp type.

Use the following procedure to connect the wires to the connectors.

1. Insert the screwdriver into the square-shaped hole.
This will open the wire's round-shaped hole.
2. Hold the screwdriver and insert the wire into the wire's round-shaped hole.
3. Take out the screwdriver from the square-shaped hole.

The round-shaped hole will then close, and the wire will be held securely in place.

To remove the wire, re-insert the screwdriver into the square-shaped hole and when the wire's spring clamp releases, pull the wire out.

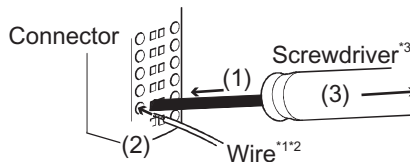

*1 Wire should be AWG24 to AWG18 thick, and twisted.

Applicable wire sizes are UL1015 and UL1007.

*2 Be sure to strip at least 7.0mm [0.28in.] of cover from the wire.

IMPORTANT

- Be sure to strip only the amount of cover required. If too much cover is removed, the end wires may short against each other, or against an electrode, which can create an electric shock. If not enough cover is removed the wire cannot carry a charge.
 - Do not solder the wire itself. This could lead to a bad or poor contact.
 - Insert each wire completely into its opening. Failure to do so can lead to a unit malfunction or short, either against wire filaments, or against an electrode.
- *3 Do not rotate the point of the screwdriver inside the square-shaped opening. It may cause a malfunction.

6

FLEX NETWORK Connector

1. FLEX NETWORK Specifications
2. Wiring to the FLEX NETWORK Connector

This section explains the interface and communication specifications of the FLEX NETWORK board type unit (model with FLEX NETWORK I/F) and the wiring to the FLEX NETWORK Connector.

This section describes the FLEX NETWORK Connector packaged with the FLEX NETWORK board type unit of the GP3000 series.

This connector is an accessory of the GP unit. It is also offered as an optional maintenance item by Digital Electronics Corporation.

SEE → 2.3 *Optional Items for the FLEX NETWORK Board Type (page 2-6)*

NOTE • When you use the FLEX NETWORK board type unit of the GP3000 series, read this section in conjunction with the specifications of your GP series (Chapter 4).

6.1 FLEX NETWORK Specifications

Connect the FLEX NETWORK Connector (accessory) to the GP unit and then connect I/O units or other FLEX NETWORK units.

6.1.1 FLEX NETWORK Interface (Connector)

Applicable connector	284510-6 <Tyco Electronics AMP.>		
		Signal Name	Description
	1	TR+	CH1 communication data
	2	TR-	CH1 communication data
	3	SLD	CH1 cable, shielded wire
	4	TR+	CH2 communication data
	5	TR-	CH2 communication data
6	SLD	CH2 cable, shielded wire	

6.1.2 Flex Network Data Transfer Settings

Communication Type	1:N
Connection Method	Multi Drop
Transfer Distance	At 6Mbps 200m per CH, at 12Mbps 100m per CH
Transfer Method	During cyclic period, distributed transmission, Half-duplex
Transfer Speed	6Mbps, 12Mbps
Transfer I/F	Differential method, Pulse transfer resistance
Error Check	Format check, bit check, CRC-12 check
No. of Stations	63 stations max., Bit variable input: 256 points, Bit variable output: 256 points, Integer variable input: 64 points, Integer variable output: 64 points (depending on type of units used.)

NOTE

- For details about the FLEX NETWORK, refer to the user manual for the respective FLEX NETWORK product.

6.2 Wiring to the FLEX NETWORK Connector

6.2.1 FLEX NETWORK Communication Cable

Use the following FLEX NETWORK Communication Cable when connecting to the FLEX NETWORK Unit.

Model	Length per Unit
FN-CABLE2010-31-MS	10m
FN-CABLE2050-31-MS	50m
FN-CABLE2200-31-MS	200m

6.2.2 Wiring to the FLEX NETWORK Connector

⚠ WARNING

- !** Be sure to remove the FLEX NETWORK Connector from the GP unit prior to starting wiring. Failure to do so may cause an electric shock.

Remove the wire's external covering and insert the wire center strand into the opening.

The applicable wire size is AWG28-16. Strip at least 7.0mm [0.28in.] of cover from the wire.

Unit: mm[in.]

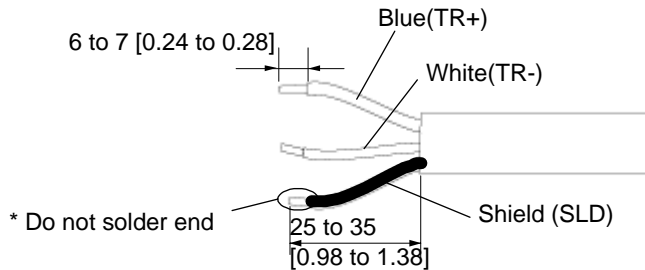
**IMPORTANT**

- Tightening torque is 0.25N-m.
- Be sure to tape or put a plastic tube over the shield line.
- Do not solder the wire itself. This could lead to a bad or poor contact.

NOTE

- Use a small sized screwdriver to tighten the set screws. (Point depth: 0.6mm [0.02in.], point height: 2.5mm [0.10in.])
- If the central wire's end (individual) wires are not twisted correctly, the end wires may either short against each other, or against an electrode. To use a pin terminal, reference the recommended pin terminal shown below or equivalent terminals. The optimum pin terminal varies depending on the size of the electric wire to be used.

-966067- manufactured by Tyco Electronics AMP.

7 | Installation and Wiring

1. Installation
2. Wiring Precautions
3. CF Card Insertion/Removal
4. USB Cable Clamp Attachment/Removal
5. Attaching the AUX Connector

7.1 Installation

This section describes the procedures and precautions for installing the GP Series units.

■ Check the Installation Gasket's Seating

It is strongly recommended that you use the installation gasket, since it absorbs vibration in addition to repelling water.

For the procedure for attaching the installation gasket, refer to "[8.3 Replacing the Installation Gasket](#)".

SEE → [8.3 Replacing the Installation Gasket \(page 8-4\)](#)

- IMPORTANT**
- Before installing the GP into a cabinet or panel, check that the installation gasket is securely attached to the unit.
 - A gasket which has been used for a long period of time may have scratches or dirt on it, and could have lost much of its dust and drip resistance. Be sure to change the gasket periodically (or when scratches or dirt become visible).

■ Creating a Panel Cut

Create the correct sized opening required to install the GP, using the installation dimensions given.

Decide the panel's thickness based on the level of panel strength required.

- SEE →**
- GP-3200 Series*
 - *Panel Cut Dimensions (page 4-11)*
 - GP-3300 Series*
 - *Panel Cut Dimensions (page 4-25)*
 - GP-3400 Series*
 - *Panel Cut Dimensions (page 4-37)*
 - GP-3500 Series*
 - *Panel Cut Dimensions (page 4-52)*
 - GP-3600 Series*
 - *Panel Cut Dimensions (page 4-66)*
 - GP-3700 Series*
 - *Panel Cut Dimensions (page 4-78)*

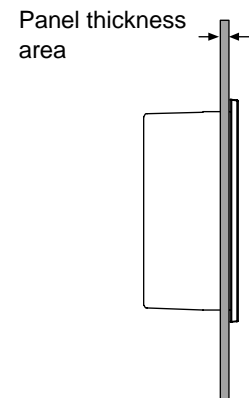
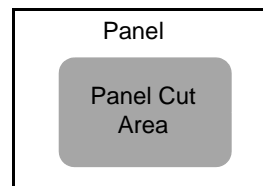

- NOTE**
- Check that the installation panel or cabinet's surface is flat, in good condition and has no jagged edges. Also, if desired, metal reinforcing strips can be attached to the inside of the panel, near the Panel Cut, to increase the panel's strength.

■ Installation Requirements

- For easier maintenance, operation, and improved ventilation, be sure to install the GP at least 100 mm [3.94 in.] away from adjacent structures and other equipment.

Unit: mm[in.]

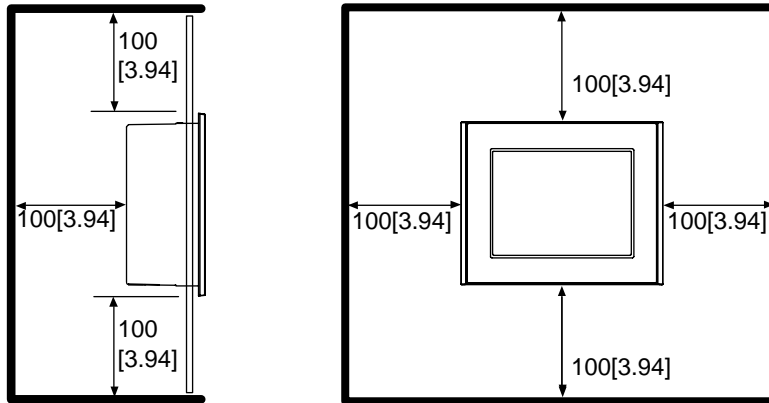

- Be sure that the surrounding air temperature and the ambient humidity are within their designated ranges. (Surrounding air temperature: 0 to 50°C, Ambient humidity: 10 to 90%RH, Wet bulb temperature: 39°C max.) When installing the GP on the panel of a cabinet or enclosure, "Surrounding air temperature" indicates both the panel face and cabinet or enclosure's internal temperature.

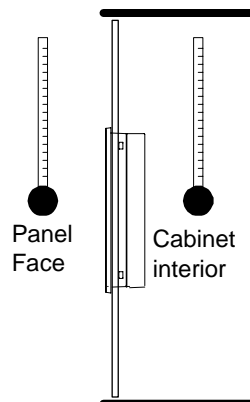

- Be sure that heat from surrounding equipment does not cause the GP to exceed its standard operating temperature.

- When installing the GP in a slanted panel, the panel face should not incline more than 30°.

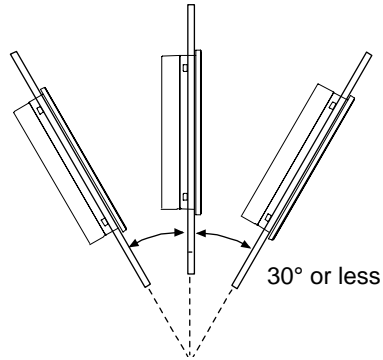

- When installing the GP in a slanted panel, and the panel face inclines more than 30°, the ambient temperature must not exceed 40°C. You may need to use forced air cooling (fan, A/C) to ensure the ambient operating temperature is 40°C or below.
- When installing the GP vertically, position the unit so that the Power Input Terminal Block is also vertical.

■Installing the GP

- (1) Insert the GP into the panel cut, as shown.

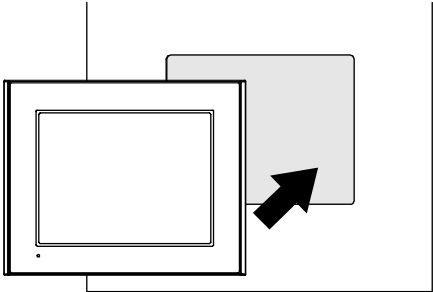

- (2) Insert the installation fasteners into the GP insertion slots, at the left-and-right or top-and-bottom of the unit. (total: 4 slots). Only the AGP-3750T has 8 slot locations.

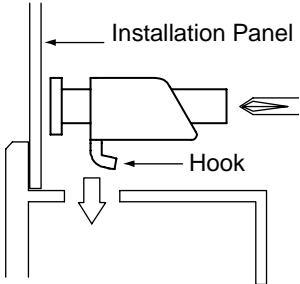

The following shows the insertion slots location that are on both left and right sides. (GP-3200 Series)

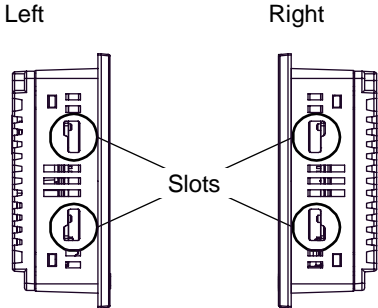

The following shows the insertion slots location that are on the top and bottom sides. (GP-3300 Series)

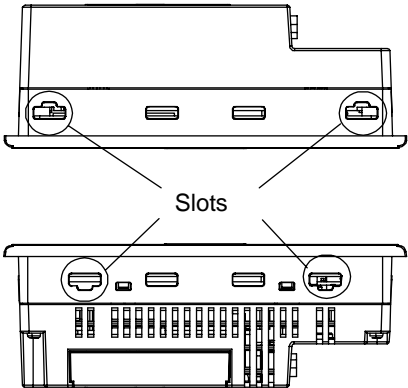

IMPORTANT • Insert each installation fastener securely into the slot's recess (shaded area).



- (3) Insert each of the fasteners shown below.
Be sure to pull the fastener back until it is flush with the rear of the attachment hole.

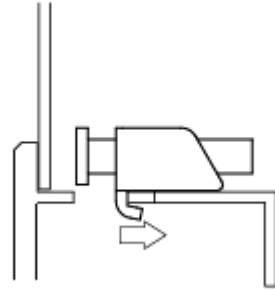

- (4) Use a Phillips screwdriver to tighten each fastener screw and secure the GP in place.

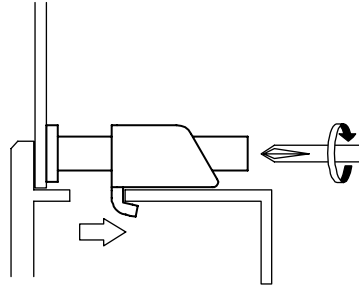

IMPORTANT





- Tightening the screws with too much force can damage the GP unit's plastic case.
- The torque required to tighten these screws is 0.5 N•m.

7.2 Wiring Precautions

This section describes the procedures and precautions for wiring power cords.

7.2.1 Connecting the Power Cord

WARNING

-  To avoid an electric shock, prior to connecting the GP unit's power cord terminals to the power terminal block, confirm that the GP unit's power supply is completely turned OFF, via a breaker, or similar unit.
-  Supplying a power voltage other than that specified will damage the power source and the GP unit.
-  Since there is no power switch on the GP unit, be sure to attach a breaker-type switch to its power cord.
-  When the FG terminal is connected, be sure the wire is grounded.

IMPORTANT

- When the FG terminal is connected, be sure the wire is grounded. Not grounding the GP unit will result in excess noise and vibration.
- The SG and FG terminals are connected internally in the GP unit.
When connecting the SG wire to another device, be sure that the design of the system/connection does not produce a shorting loop.

■ When the AC type

Power Cord Specifications

IMPORTANT • Use copper conductors only.

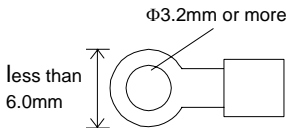
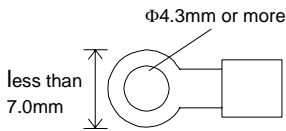
	AC Power Cord	Grounding Wire
Power Cord	Double-insulated Wire 1.25 to 2.0mm ² (16-14AWG)	1.25 to 2.0mm ² (16-14AWG)
Recommended Ring Terminal *1	J.S.T. Mfg. Co., Ltd V2-MS3 compatible 	J.S.T. Mfg. Co., Ltd V2-P4 compatible 

*1 In order to prevent a short circuit caused by loose screws, make sure to use a crimp-type terminal with insulating sleeve.

Connecting the Power Cord

When connecting the AC type power cord, be sure to follow the procedures given below.

- (1) Be sure that the GP's power cord is not plugged in to the power supply.
- (2) Remove the Terminal Strip's clear plastic cover.
- (3) Remove the screws from the two (2) terminals (L, N) and FG (Frame Ground) Terminal, position the Ring Terminals and reattach the screws. (Check each wire to make sure the connections are correct.)

IMPORTANT • The torque required to tighten these screws are as follows:

Terminal Block: 0.5 to 0.6N•m[5-7Lb•In.]

FG (Frame Ground) Terminal: 0.6 to 0.7N•m

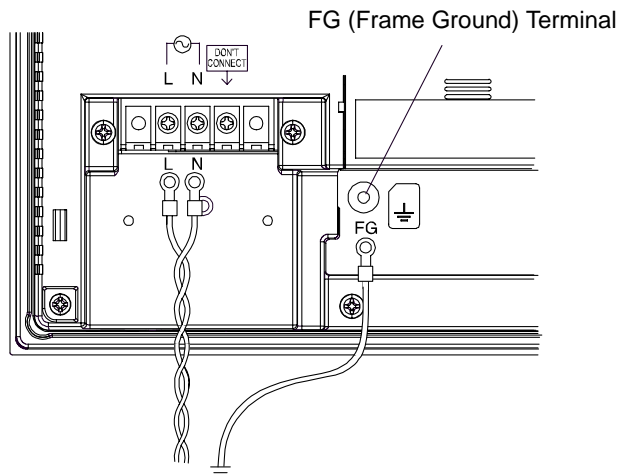

- (4) Reattach the Terminal Strip's clear plastic cover.

■When the DC Type

Power Cord Specifications

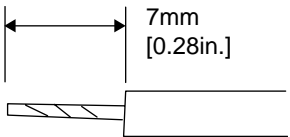
Power Cord Diameter	0.2 to 2.5mm ² (24-12AWG)
Conductor Type	Simple or Twisted Wire
Conductor Length	

- IMPORTANT**
- Use copper conductors only.
 - If the Conductor's end (individual) wires are not twisted correctly, the end wires may either short against each other, or against an electrode.

Power Connector (Plug) Specifications

When the GP-3200/3300/3400 series is used;

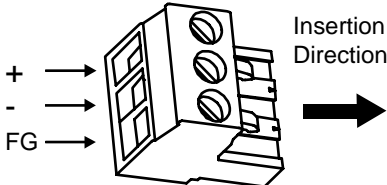
	+	24V
	-	0V
	FG	FG Grounding Terminal connected to the GP

- NOTE**
- The power supply connector (plug) is CA5-DCCNM-01 (made by Pro-face) or MSTB2,5/3-ST-5,08 (made by Phoenix Contact*¹).

When the GP-3500/3600/3700 series is used;

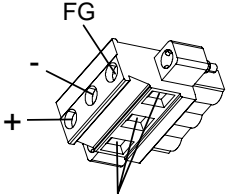
 <p>Power Cord Insertion Holes</p>	+	24V
	-	0V
	FG	FG Grounding Terminal connected to the GP

- NOTE**
- The power supply connector (plug) is CA5-DCCNL-01 (made by Pro-face) or GMVSTBW2, 5/3-STF-7, 62 (made by Phoenix Contact*¹).

*1 For details, please contact your local Phoenix Contact distributor.

Wiring

When connecting the Power Cord, use the following items when performing wiring. (Items are made by Phoenix Contact.)

Recommended Driver	SZF 1-0.6x3.5 (1204517)
Recommended Pin Terminals	AI 0.25-6BU (3201291) AI 0.34-8TQ (3200865) AI 0.5-8WH (3200014) AI 0.75-8GY (3200519) AI 1-8RD (3200030) AI 1.5-8BK (3200043) AI 2.5-8BU (3200522)
Recommended Pin Terminal Crimp Tool	CRIMPFOX ZA3 (1201882)

Connecting the Power Cord

- IMPORTANT**
- Be sure to remove the connector from the GP unit prior to starting wiring. Failure to do so may cause an electric shock.
 - The temperature rating of field installed Conductors:75°C only.

When the GP-3200/3300/3400 series is used;

- (1) Confirm that the power cord is unplugged from the power supply.
- (2) When using GP-3200/3300 Series, remove the power connector (plug) from the main unit.
(When using GP-3400 Series, the power connector (plug) is packaged with other accessories.)
- (3) Strip the membrane of the power cord, twist the wire ends, and connect them to the Power Connector.

- IMPORTANT**
- Use a flat-blade screwdriver (Size 0.6 X 3.5) to tighten the terminal screws.
The torque required to tighten these screws is 0.5 to 0.6N•m[5-7Lb•In.].
 - Do not solder the cable connection.

- (4) Reattach the Power Connector(plug).

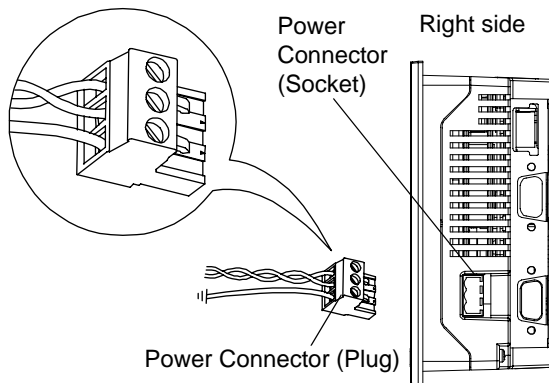

(The figure shows the GP-3300 series.)

- NOTE**
- Be sure to twist the power cords together, up to the power connector.

When the GP-3500/3600/3700 series is used;

- (1) Confirm that the power cord is unplugged from the power supply.
- (2) Remove the power connector (plug) from the main unit.
- (3) Loosen the three screws in the center of the Power Connector (plug).
- (4) Strip the sheath of the power cord, twist the wire ends, insert them into the bar terminals.
- (5) Fix them with screws.

- IMPORTANT**
- Use a flat-blade screwdriver (Size 0.6 X 3.5) to tighten the terminal screws.
The torque required to tighten these screws is 0.5 to 0.6N•m[5-7Lb•In.].
 - Do not solder the cable connection.

- NOTE**
- Be sure to twist the power cords together, up to the power connector.

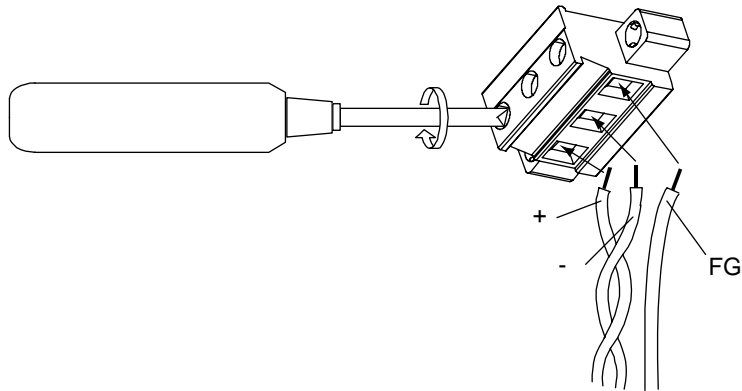

- (6) Attach the Power Connector (Plug) to the GP and fix it to the GP main unit with right/left tightening screws.

7.2.2 Connecting the Power Supply

This section describes the precautions for supplying a power voltage.

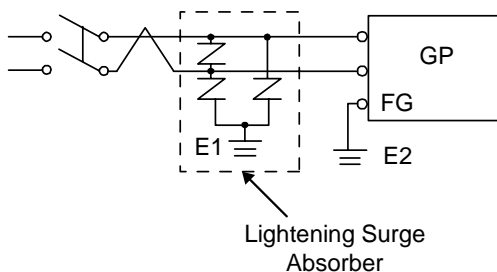
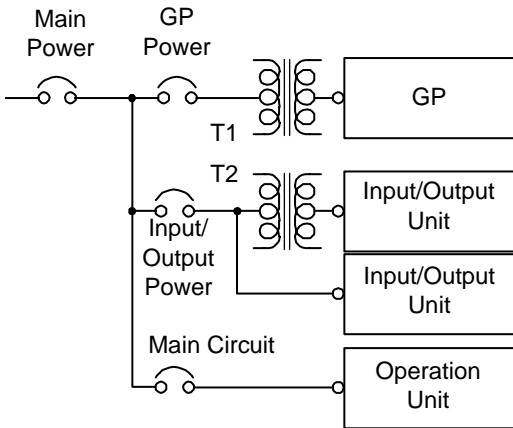
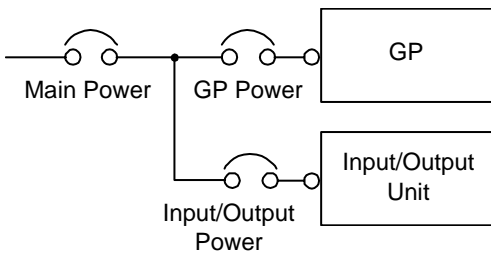
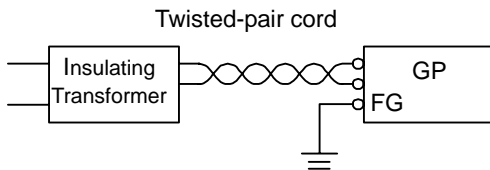
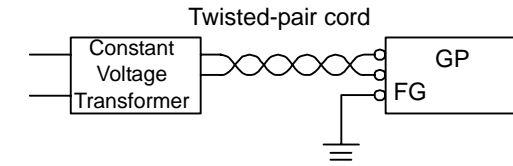

- If the supplied voltage exceeds the GP unit's range, connect a constant voltage transformer.

SEE → Chapter 4 Specifications (page 4-1)

- For between the line and ground, select a power supply that is low in noise. If there is an excess amount of noise, connect a insulating transformer.

IMPORTANT • Use constant voltage and insulating transformers with capacities exceeding Power Consumption value.

- When supplying power to the GP unit, be sure to separate the input/output and power lines, as shown.
- To increase the noise resistance quality of the power cord, simply twist each power wire before attaching the Ring Terminal.
- The power supply cable must not be bundled or positioned close to main circuit lines (high voltage, high current), or input/output signal lines.
- Connect a lightning surge absorber, as shown in the diagram, to deal with power surges.
- To avoid excess noise, make the power cord as short as possible.
- 24V DC input unit is must be used with a Class 2 power supply.

IMPORTANT • Be sure to ground the surge absorber (E1) separately from the GP unit (E2).

- Select a surge absorber that has a maximum circuit voltage greater than that of the peak voltage of the power supply.

7.2.3 Grounding

This section describes the precautions for grounding the GP unit.

⚠ CAUTION

❗ Do not use common grounding, since it can lead to an accident or machine breakdown.

(a) Exclusive Grounding (BEST)

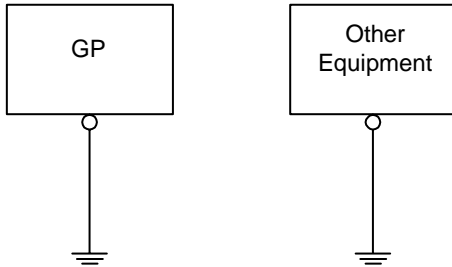

(b) Exclusive Grounding (OK)

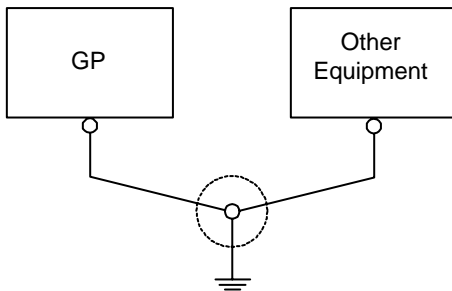

(c) Common Grounding (Not OK)

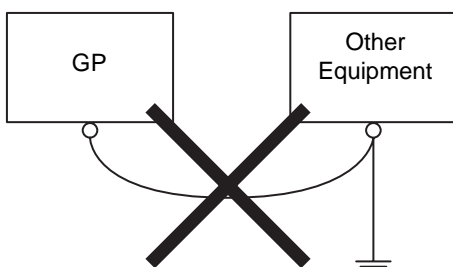

• When supplying power to the GP unit, be sure to separate the input/output and power lines, as shown. [diagram (a)]

IMPORTANT

- Check that the grounding resistance is 100Ω or less.
- FG and SG terminals are internally connected in the GP. When connecting an external device to the GP using the SG terminal, be sure to check that no short-circuit loop is created when you setup the system.
- The grounding wire should have a cross sectional area greater than 2mm^2 . Create the grounding point as close to the GP unit as possible, and make the wire as short, as possible. When using a long grounding wire, replace the thin wire with a thicker wire, and place it in a duct.

• If exclusive grounding is not possible, use a common grounding point. [diagram (b)] A D-type grounding or equivalent should be used for the grounding point.

NOTE

- If the equipment does not function properly when grounded, disconnect the ground wire from the FG terminal.

7.2.4 Wiring Precautions

To help prevent noise and interference problems, separate all control, communication and power lines by placing them in a separate ducts.

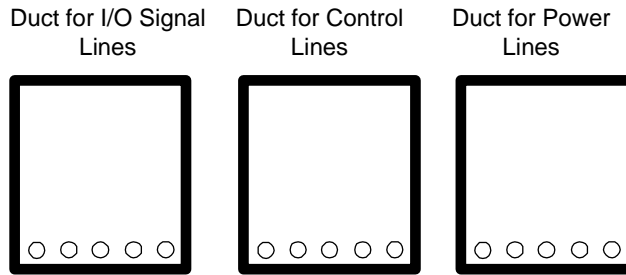

If different wires must be placed in the same duct, separate them with an earthed/grounded divider.

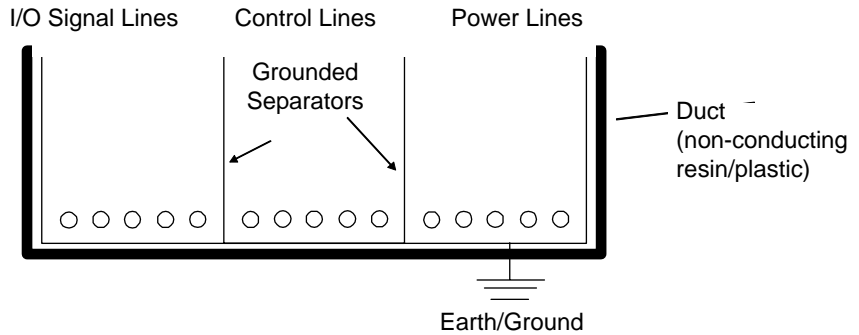

NOTE • If the lines cannot be separated, use shielded lines and create a ground from the shield line.

IMPORTANT

- Use noise-reducing external wiring methods to increase overall system reliability.
- To prevent power surges or noise interference, use ducts to separate all DC I/O or current circuit wires from communication cables.
- To prevent malfunctions due to noise, communication cables must be wired separately from high-frequency lines and power lines such as high-voltage lines, high-current lines, and inverters.

7.2.5 Installation Precautions

- IMPORTANT** • When you use the DIO/FLEX NETWORK board type unit of the GP3000 series, read the following installation precautions.

External power failure or failure of the GP unit may cause abnormal behavior.

To prevent such abnormal behavior from leading to the abnormal operation of the entire system, and to ensure fail-safe operation, configure circuits which may lead to machine damage or accident due to abnormal operation (emergency stop circuit, protection circuit, interlock circuit, etc.) externally to the GP.

This section describes examples of the system circuit design to improve system reliability and to ensure optimum performance.

■ Fail-safe Design of the Electric Circuit

Design the electric circuit with consideration to equipment malfunctions caused when the GP is turned on by a delay among the startup times of the control equipment connected to the GP output unit (especially the one operated by a DC power supply), the GP unit itself, and the program. When remote I/O is used, create a program that checks the status of the terminal with a logic program.

For example, connect voltage relay coils to the power supply circuit of the GP output unit and the power supply circuit of the connected control equipment, and connect the contact to the GP input unit. Configure the circuit to check the ON signal from the voltage relay in the logic program before executing the ladder of the control equipment connected to the GP output unit.

■ Rated Voltage

Be sure to supply an appropriate power supply voltage to your GP that is within the specified range.

■ Power-down

All GP units except for AGP-3300*/AGP-3301* enter power-down status when an instantaneous power interruption of the rated voltage continues for 20ms or longer.

AGP-3300*/AGP-3301* enters power-down status when an instantaneous power interruption of the rated voltage continues for 10ms or longer.

When the GP unit enters power-down status, it stops the calculation even if the instruction is not finished.

For example, when the GP unit enters power-down status while 100 words of data are being transferred by an FMOV instruction, the transfer stops midway.

Consequently, design your program with consideration to power-down occurrences.

■Emergency Stop Circuit

Do not process emergency stop signals with a software program by inputting the signal to the GP.

Configure the emergency stop circuit externally to the GP as shown in the figure below:

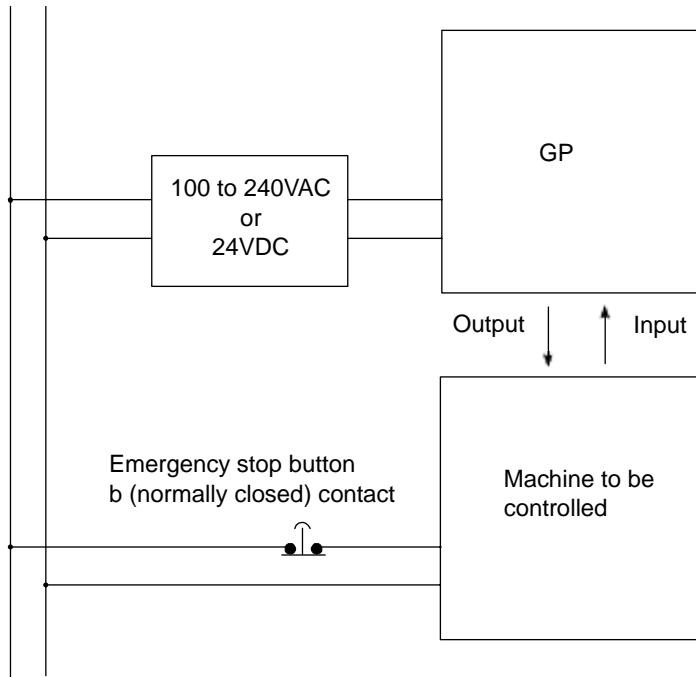

■Interlock Circuit 1

To use the GP or a PLC to control a motor circuit for forward/reverse rotation, configure the interlock circuit shown below externally to the GP.

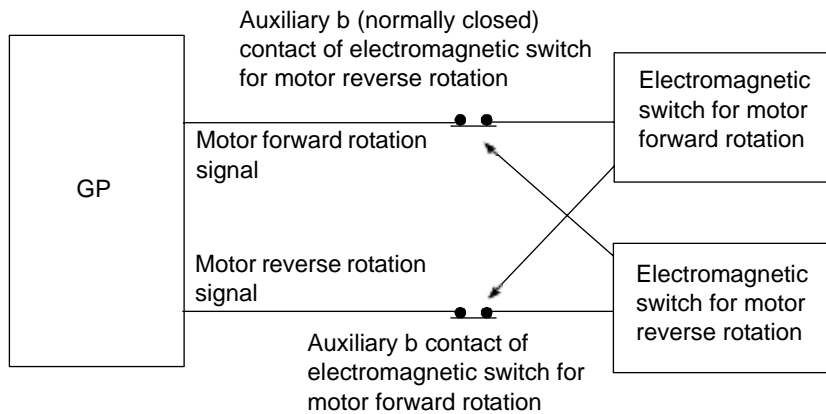

NOTE

- After executing an internal program, the GP outputs ON/OFF information to the output devices at the same time. For example, the electromagnetic switches for forward and reverse rotation of a motor are turned on and off at the same time. Consequently, a situation may arise in which both of the main contacts of the motor circuits for the electromagnetic switches for forward and reverse rotation may turn on, causing a short-circuit of the R and T phases. To avoid this situation, you need to provide the interlock circuit shown above or use an electromagnetic switch equipped with a mechanical interlock for a forward/reverse circuit.

■ Interlock Circuit 2

If there is a possibility that the abnormal operation of the GP may lead to an accident, design a fail-safe measure to configure an interlock circuit with external hardware devices.

For a system which requires the running motor to stop before all other processes when the travel limit switch is activated, never design a system in which the signals from the travel limit switch are input to the input terminals of the GP and then processed using software.

Configure a circuit that reliably stops the running motor using hardware as shown below.

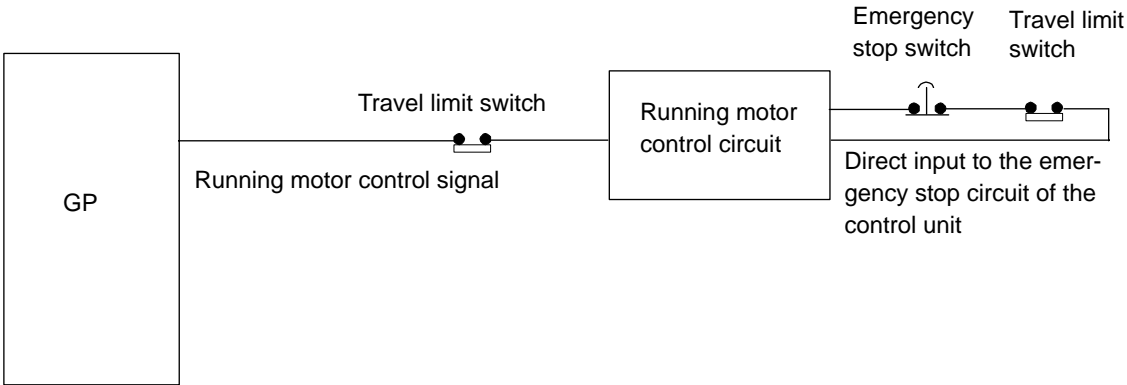







7.3 CF Card Insertion/Removal

This section describes how to insert and remove a CF Card.

CAUTION

When using the GP Unit and a CF Card, observe the following precautions:

-  Prior to inserting or removing a CF Card, be sure to turn the AGP unit's CF Card ACCESS switch OFF and to confirm that the ACCESS lamp is not lit. If you do not, CF Card internal data may be damaged or lost.
-  While a CF Card is being accessed (Status LED: Blinking in green), NEVER turn OFF or reset the GP, or insert or remove the CF Card. If you do not, CF Card internal data may be damaged or lost.
-  Prior to inserting a CF Card, familiarize yourself with the CF Card's front and rear face orientation, as well as the CF Card connector's position. If the CF Card is not correctly positioned when it is inserted into the Multi Unit, the CF Card's internal data and the GP unit may be damaged or broken.
-  Be sure to use only CF Cards manufactured by the Digital Electronics Corporation. The CF Card's internal data may be damaged when using another manufacturer's CF Card.
-  Once GP data is lost, it cannot be recovered. Since accidental data loss can occur at any time, be sure to back up all GP screen and CF Card data regularly.
-  Be sure to follow the instructions given below to prevent the CF Card's internal data from being destroyed or a CF Card malfunction from occurring:
 - DO NOT bend the CF Card.
 - DO NOT drop or strike the CF Card against another object.
 - Keep the CF Card dry.
 - DO NOT touch the CF Card connectors.
 - DO NOT disassemble or modify the CF Card.

7.3.1 Inserting the CF Card

Use the following steps to insert the CF Card in the GP.

- (1) Pull the CF Card Cover frontward and then open it upward.

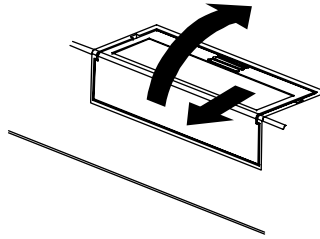

- (2) Insert the CF Card in the CF Card Slot, until the eject button is pushed forward.

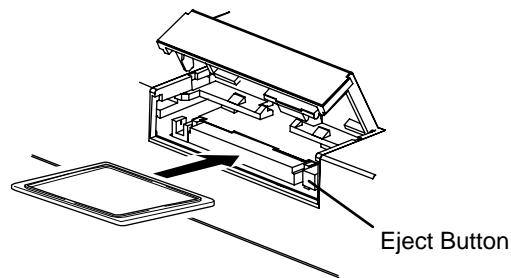

- (3) Close the cover. (As shown.)

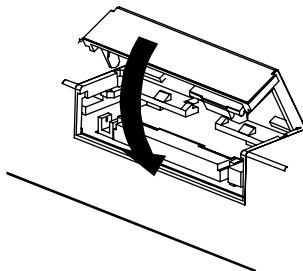
**NOTE**

- Make sure that the CF Card cover is closed only accessing the CF Card.

7.3.2 Removing the CF Card

Simply reverse the steps shown in the previous “Inserting CF Card” explanation. Prior to pressing the eject button to remove the CF Card, confirm that the CF Card Access LED is turned OFF.

7.3.3 CF Card Handling

The CF Card has a data overwrite limit of approximately 100,000 times. Therefore, be sure to back up all CF Card data regularly to another storage media. (100,000 times assumes the overwriting of 500KB of data in DOS format.) Two methods are available for backing up data. After using either method (1) or method (2), use your personal computer to save your data to the CF Card.

(1) If your PC is equipped with a PC Card Slot

To view CF Card data on a personal computer, first, insert the CF Card into a CF Card Adapter (GP077-CFAD10).

(2) If your PC is NOT equipped with a PC Card slot

Use a commercially available PC Card Reader, or a CF Card Reader.

7.4 USB Cable Clamp Attachment/Removal

This clamp is used to prevent the USB cable connected to the USB Host Interface on the bottom of the GP unit from being unplugged due to vibration or other causes.

IMPORTANT

- When the USB Host Interface is used in the hazardous locations specified in UL1604, use the USB holder to secure the USB cable. The USB Host Interface cannot be used unless the connectors attached to the GP unit and connected device are completely secured to prevent disconnection.

7.4.1 GP-3200 Series

■ Attachment

- (1) Before starting the procedure, pull up the tabs on both sides of the USB Holder and remove the USB Cover.
- (2) Attach the USB Holder to the USB Host Interface part of the main unit. Hook the upper pick of the USB holder to the attachment hole of the main unit and then insert the lower pick as shown below to fix the USB holder.
- (3) Insert the USB cable into the USB Host Interface.
- (4) Attach the USB cover to fix the USB cable. Insert the USB cover into the tab of the USB Holder.

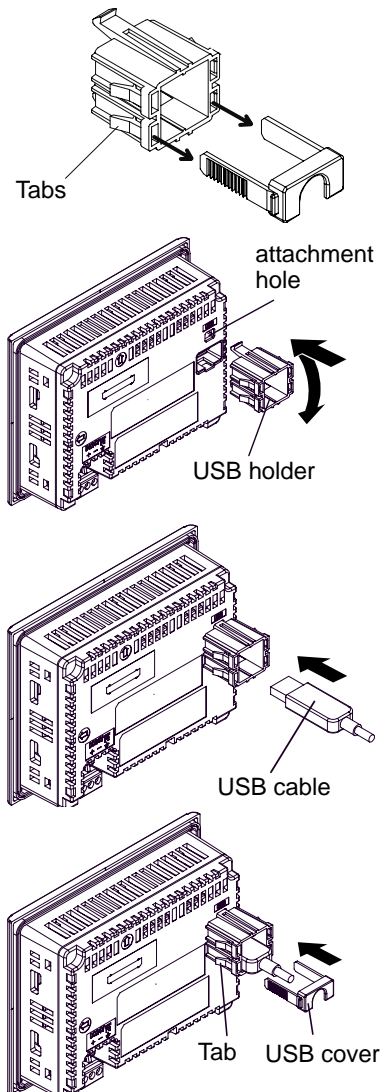

IMPORTANT

- Check the up/down orientation of the USB cover to ensure that the USB cable is secured properly.

■ Removal

- (1) Lift up the tab of the USB Holder and then remove the USB cover as shown below.

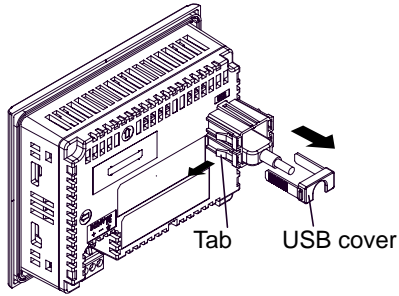

- (2) After removing the USB cable, remove the picks pushing the USB Holder from both top and bottom.

7.4.2 GP-3300 Series

■ Attachment

- (1) Insert the USB holder into the slot in front of the AGP unit's USB port and pull it down and forward.

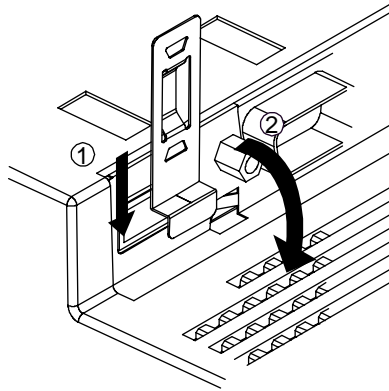

- (2) Pass the band of the USB cable clamp through the bridge of the USB holder.

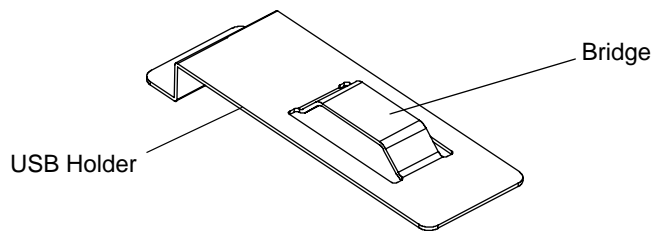

- (3) Insert the USB cable into the port. Fasten the band around the plug and secure it with the clamp.

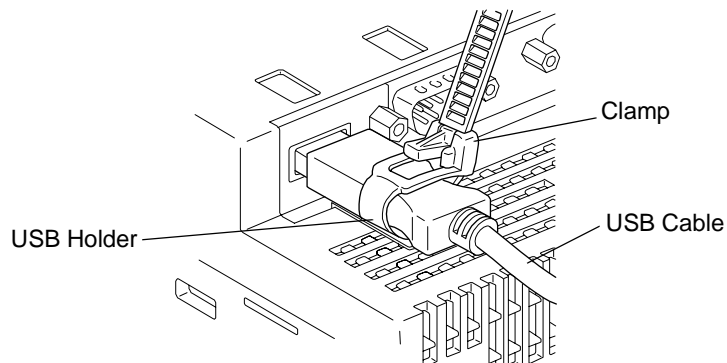

■ Removal

To remove the clamp from the USB cables, push down on the clamp strap's clip to release it while pulling up on the clamp.

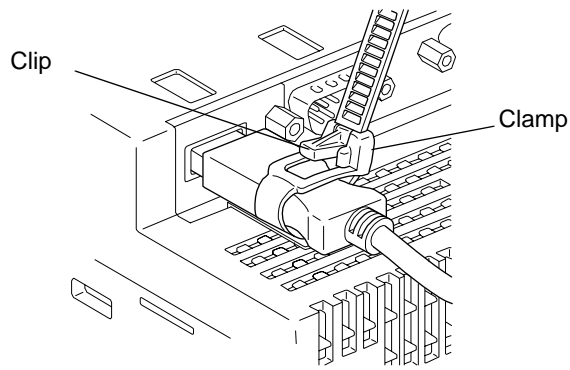

7.4.3 GP-3400/3500/3600/3700 Series

■ Attachment

- (1) Before starting the procedure, orient the two tabs on both sides of the USB Holder in the direction of the arrows in the figure and remove the USB Cover.

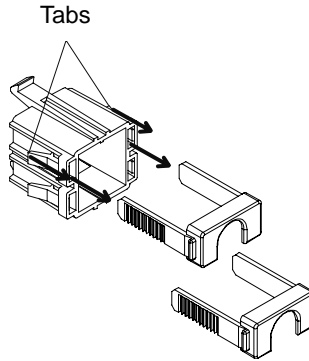

- (2) Attach the USB Holder to the USB Host Interface part of the main unit. Hook the upper pick of the USB holder to the attachment hole of the main unit and then insert the lower pick as shown below to fix the USB holder.

GP-3400/3500/3600 series

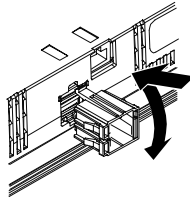

GP-3700 series

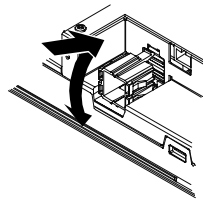

- (3) Insert the USB cable into the USB Host Interface.

GP-3400/3500/3600 series

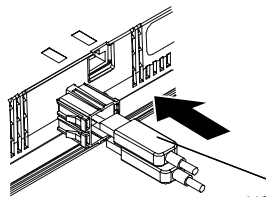

GP-3700 series

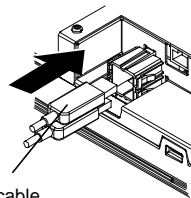

USB cable

- (4) Attach the USB cover to fix the USB cable. Insert the USB cover into the tab of the USB Holder.

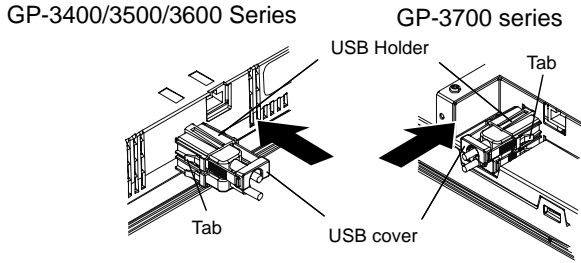

In case of installing the second USB cable, repeat the steps (3) and (4).

IMPORTANT

- When attaching the USB holder, be sure to attach all the 2 USB covers.

■Removal

- (1) Lift up the tab of the USB Holder and then remove the USB cover as shown below.

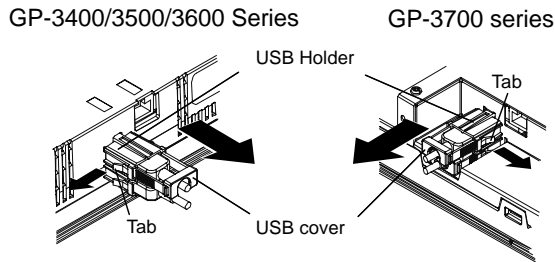

- (2) After removing the USB cable, remove the picks pushing the USB Holder from both top and bottom.

7.5 Attaching the AUX Connector

⚠ WARNING

❗ Be sure to remove the AUX Connector from the GP unit prior to starting wiring. Failure to do so may cause an electric shock.

◆ Items Required to Wire Connectors

- Screwdriver

Recommended type: SDI (Product No. 900837) <Weidmuller Japan>

If another manufacturer is used, be sure the part has the following dimensions:

point depth: 0.4mm [0.02in.]

point height: 2.5mm [0.10in.]

length from the point to the handle: 80mm [3.15in.]

Point shape should be DIN5264A, and meet Security Standard DN EN60900.

Also, the screwdriver's tip should be flat as indicated in order to access the narrow hole of the connector:



The connectors are a spring clamp type. Use the following procedure to connect the wires to the connectors.

IMPORTANT • Be sure to remove the connector from the GP unit prior to starting wiring. Failure to do so may cause an electric shock.

1. Insert the screwdriver into the square-shaped hole.

This will open the wire's round-shaped hole.

2. Hold the screwdriver and insert the wire into the wire's round-shaped hole.

3. Take out the screwdriver from the square-shaped hole.

The round-shaped hole will then close, and the wire will be held securely in place.

To remove the wire, re-insert the screwdriver into the square-shaped hole and when the wire's spring clamp releases, pull the wire out.

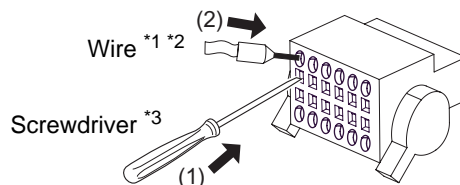

4. Insert the wired AUX connector into the auxiliary I/O or voice output interface (AUX) of the GP unit. If the connector cannot be fully inserted, turn the levers at both ends of the connector to reverse the direction and insert the connector again.

*1 Wire should be AWG22 to AWG18 thick, and twisted.

Applicable wire sizes are UL1015 and UL1007.

*2 Be sure to strip from 6.5 to 8.0mm [0.26 to 0.31in.] of cover from the wire.

IMPORTANT

- Be sure to strip only the amount of cover required. If too much cover is removed, the end wires may short against each other, or against an electrode, which can create an electric shock. If not enough cover is removed the wire cannot carry a charge.
- Do not solder the wire itself. This could lead to a bad or poor contact.
- Insert each wire completely into its opening. Failure to do so can lead to a unit malfunction or short, either against wire filaments, or against an electrode.

*3 Do not rotate the point of the screwdriver inside the square-shaped opening. It may cause a malfunction.

8

Maintenance

1. Cleaning the Display
2. Periodic Check Points
3. Replacing the Installation Gasket
4. Replacing the Backlight

This chapter explains cautions and inspection criteria that will ensure trouble-free use of the GP.

8.1 Cleaning the Display

When the surface or frame of the display become dirty, soak a soft cloth in water with a neutral detergent, wring the cloth tightly, and wipe the display.

IMPORTANT

- Do not use paint thinner, organic solvents, or a strong acid compound to clean the unit.
- Do not use hard or pointed objects to operate the touch-screen panel, since it can damage the panel surface.

8.2 Periodic Check Points

To keep your GP unit in its best condition, please inspect the following points periodically.

■ GP Operation Environment

- Is the operating temperature within the allowable range (0°C to 50°C)?
- Is the operating humidity within the specified range (10%RH to 90%RH, dry bulb temperature of 39°C or less)?
- Is the operating atmosphere free of corrosive gasses?

When using the GP unit inside a panel, the ambient environment refers to the interior of the panel.

■ Electrical Specifications

- Is the input voltage appropriate?

AC100 to 240V 50/60Hz

DC19.2 to 28.8V

■ Related Items

- Are all power cords and cables connected properly? Have any become loose?
- Are all mounting brackets holding the unit securely?
- Are there many scratches or traces of dirt on the installation gasket?

8.3 Replacing the Installation Gasket

The installation gasket provides protection against dust and moisture.

IMPORTANT

- A gasket which has been used for a long period of time may have scratches or dirt on it, and could have lost much of its water resistance. Be sure to change the gasket at least once a year, or when scratches or dirt become visible.
- The GP unit installation gasket's model number is as follows.

GP-3200 Series	ST400-WP01
GP-3300 Series	CA3-WPG6-01
GP-3400 Series	CA5-WPG8-01
AGP-35*0T	CA5-WPG10-01
AGP-3500L/3500S	CA3-WPG12-01
GP-3600 Series	CA3-WPG12-01
GP-3700 Series	CA3-WPG15-01

■ Installation Gasket Attachment Procedure

- (1) Place the GP on a flat, level surface facing the display face downwards.
- (2) Remove the gasket from the GP.
- (3) Attach the new gasket to the GP. Be sure to insert the gasket into the GP's groove so that the gasket's groove sides are vertical.

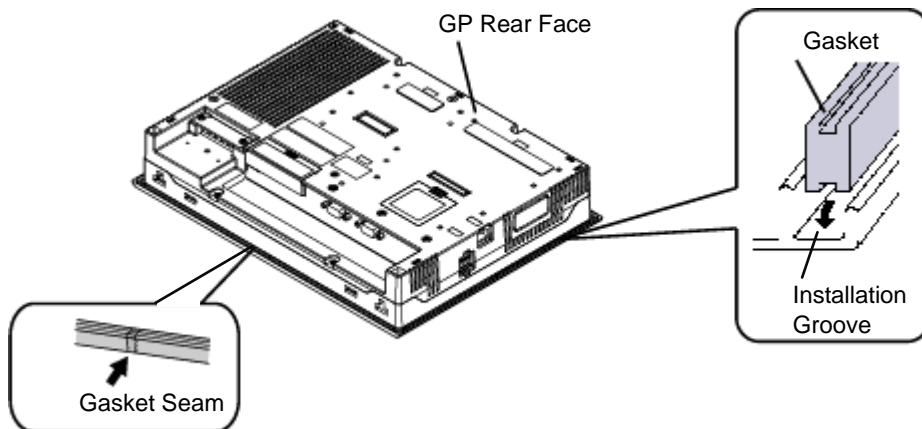

- (4) Check that the gasket is attached correctly to the GP.

IMPORTANT

- The gasket must be inserted correctly into the groove for the GP's moisture resistance to be equivalent to IP65f.
- Since the gasket is flexible but not elastic, be careful not to stretch it unnecessarily, as doing so could tear the gasket.
- Be sure the gasket's seam is not inserted into any of the unit's corners, only in the straight sections of the groove. Inserting it into a corner may lead to its eventually tearing.
- To ensure stable resistance against dust and moisture, insert the gasket so that the seam is at the bottom of the GP unit.
- The upper surface of the gasket should protrude approximately 2.0 mm out from the groove. Be sure to check that the gasket is correctly inserted before installing the GP into a panel.

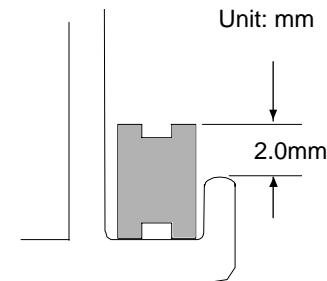

8.4 Replacing the Backlight

IMPORTANT

- The GP-3200/3300/3400's backlight and AGP-3500L's backlight cannot be replaced by the user. When the backlight needs to be replaced, please contact your local GP distributor.

8.4.1 AGP-35*0T

NOTE

- Use the following table to check that you have ordered the correct backlight.

GP	Rev*1	Backlight Model	Attachment Procedures
AGP-3500T AGP-3550T	-	CA5-BLU10T-01	SEE → ■ CA5-BLU10T-01 (page 8-6)
	Rev.2 is marked.	CA6-BLU10T-02	SEE → ■ CA6-BLU10T-02 (page 8-11)
AGP-3510T AGP-3560T	-		

1 The revision number of the GP is shown in the label affixed to the GP. In the example shown below, an asterisk "" is displayed in the position where "2" should be, meaning "Rev. 2".

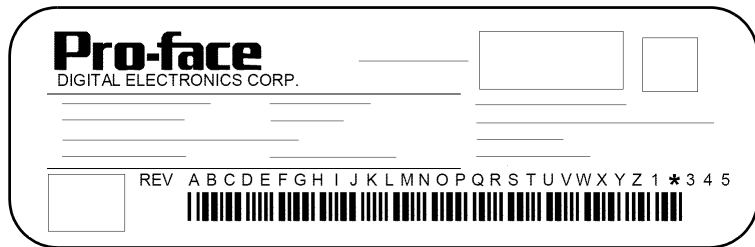

■ CA5-BLU10T-01

◆ Preparation

Please have the following ready beforehand.

- Replacement backlight (Model: CA5-BLU10T-01)
- One pair of clean (preferably new) cotton gloves.
- Phillips screwdriver (no.2)

About the Backlight

GP units use a CFL, long-life type backlight. In a real world situation, the backlight may need to be replaced depending on the GP's operating environment. It is recommended that it be replaced periodically.

A backlight life refer to “■ Display Specifications (page 4-43)”, when the backlight is lit continuously (time required for brightness to fall to half its normal level.)

NOTE

- If the backlight or the display unit is damaged, the screen display will go out. Even if the screen goes out, however, there is a possibility that the touch panel is still operating correctly. Therefore, since any type of touch panel contact could have an unexpected or dangerous effect or result, be sure not to touch the screen when this condition occurs.

 **WARNING**

 **[Electric shock]**

- Whenever changing the backlight, be sure the GP's power cord has been disconnected and that the unit is cooled down.
- When the GP's power cord is connected and the GP is ON, high voltage runs through the wires in the backlight area do not touch them!

 **[Burn]**

- When the GP's power has just been turned OFF, the backlight area is still very hot! Be sure to wear gloves to prevent being burned.

 **[Glass]**

- The backlight is very fragile. Do not touch the glass tube directly or try to remove its power cord. If the glass tube breaks you may be injured.

◆ Procedure for replacing the backlight

- (1) Unplug the power cord from the main power supply.

IMPORTANT

- Remove the GP unit from the equipment to which the unit has been incorporated, and work with the GP unit with the display surface facing downward. Be sure to perform the backlight changeover on a flat, level surface. This will prevent damage to the GP unit and the accidental cutting of any of its power cord.
- Be sure to protect the display surface to prevent damage during the operations.

- (2) Remove the retaining screws (6) on the rear cover.

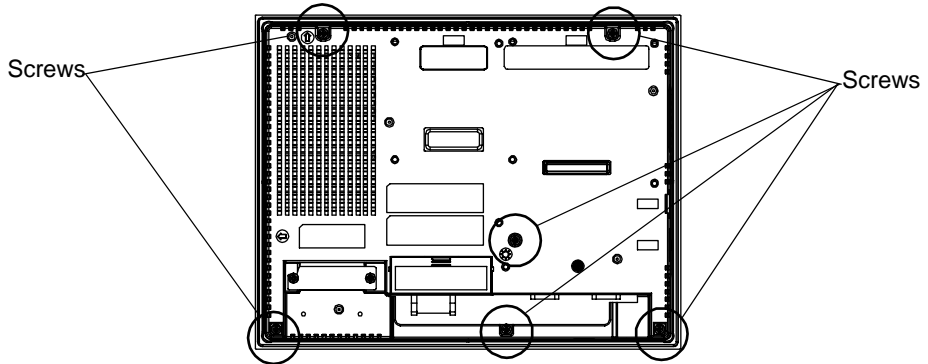

IMPORTANT • Do not let the attachment screws fall inside the GP

- (3) Open the rear cover carefully from the bottom of the unit to the top.
- (4) Remove the setscrew (1) on the circuit board chassis.

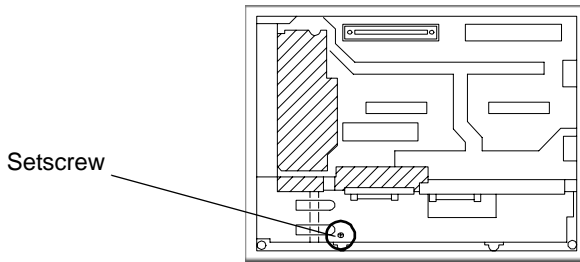

- (5) Open the circuit board chassis, it's turn left to right.

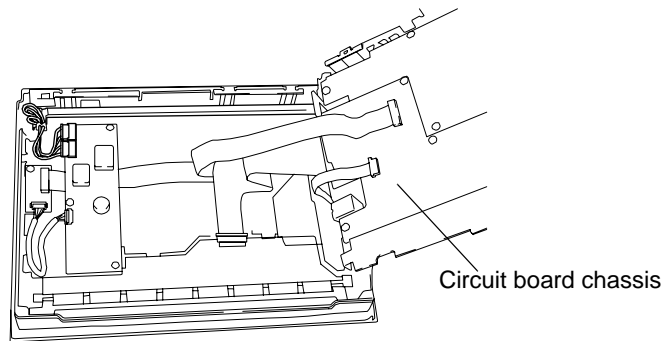

IMPORTANT • A hot circuit board chassis can burn you. Be sure the chassis has cooled completely prior to replacing the backlights.

- (6) Disconnect the Backlight Unit cable from the connector on the inverter board, and then remove the cable from the cable clamp.

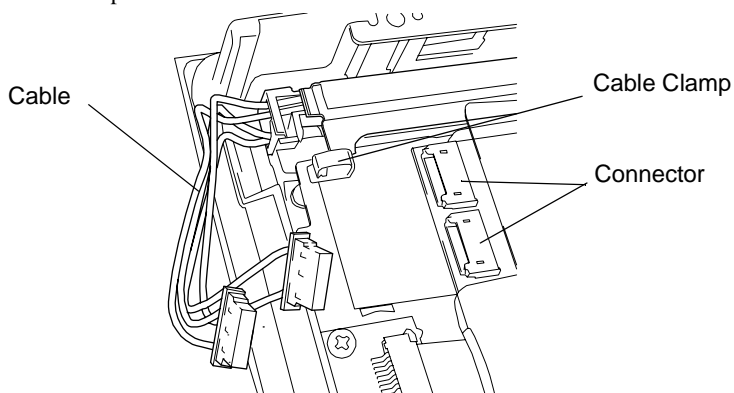

- (7) Remove the hook from the Backlight Unit.

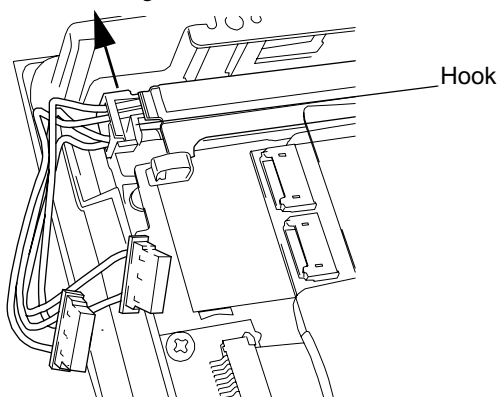

- (8) Remove the Backlight Unit while sliding it along the groove.

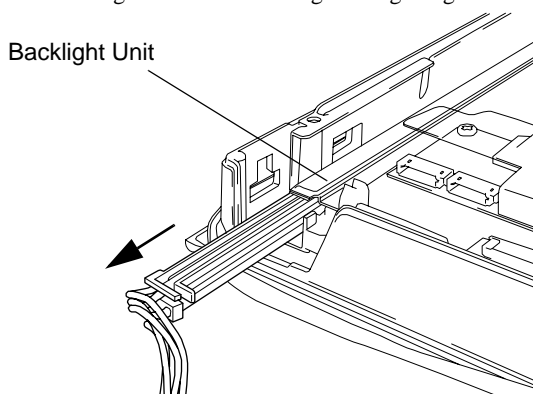

(9) Insert a new Backlight Unit while sliding it along the groove.

IMPORTANT

- Be careful that no dust or dirt adheres to the backlight surface or to the backlight holder.
- Be careful not to soil the Backlight with moisture, oil content or finger prints; otherwise, the life duration of the Backlight will be shortened.

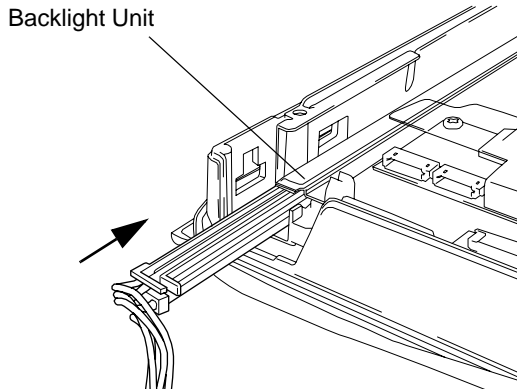

(10) Insert the Backlight Unit cable to the connector on the inverter board, and secure the cable with the cable clamp.

IMPORTANT

- Be sure the cable is inserted completely into the backlight connector. Failure to do so may cause arcing, which can damage the connector.

(11) Return the circuit board chassis to the original position, and reattach the setscrew. The necessary torque is 0.5N•m.

(12) Return the rear face cover to the original position, and secure the cover in place using the mounting screws (6). The necessary torque is 0.5N•m.

IMPORTANT

- The cable clamp is used to prevent the cable from being caught inside in the GP unit and possibly damaged. Be sure to insert the cable in the cable clamp around the cable before replacing the rear cover.
- If any of the screws is missing, check if it fell inside the GP unit's chassis. If the power is turned ON while a screw is inside, it may cause an accident or fire.

NOTE

- After backlight replacement is completed, turn the GP unit's power ON and check if the screen's display is normal. If the display is not correct, please contact the GP distributor from whom you purchased the backlight unit.

■CA6-BLU10T-02

◆ Preparation

Please have the following ready beforehand.

- Replacement backlight (Model: CA6-BLU10T-02)
- One pair of clean (preferably new) cotton gloves.
- Phillips screwdriver (no.1:for the attachment of the backlight unit's one (1) attachment setscrew.
no.2:for the attachment of the other mounting screws.)

About the Backlight

GP units use a CFL, long-life type backlight. In a real world situation, the backlight may need to be replaced depending on the GP's operating environment. It is recommended that it be replaced periodically.

A backlight life refer to “■ Display Specifications (page 4-43)”, when the backlight is lit continuously (time required for brightness to fall to half its normal level.)

NOTE

- If the backlight or the display unit is damaged, the screen display will go out. Even if the screen goes out, however, there is a possibility that the touch panel is still operating correctly. Therefore, since any type of touch panel contact could have an unexpected or dangerous effect or result, be sure not to touch the screen when this condition occurs.

⚠ WARNING

⚠ [Electric shock]

- Whenever changing the backlight, be sure the GP's power cord has been disconnected and that the unit is cooled down.
- When the GP's power cord is connected and the GP is ON, high voltage runs through the wires in the backlight area do not touch them!

⚠ [Burn]

- When the GP's power has just been turned OFF, the backlight area is still very hot! Be sure to wear gloves to prevent being burned.

⚠ [Glass]

- The backlight is very fragile. Do not touch the glass tube directly or try to remove its power cord. If the glass tube breaks you may be injured.

◆ Procedure for replacing the backlight

(1) Unplug the power cord from the main power supply.

- IMPORTANT**
- Remove the GP unit from the equipment to which the unit has been incorporated, and work with the GP unit with the display surface facing downward. Be sure to perform the backlight changeover on a flat, level surface. This will prevent damage to the GP unit and the accidental cutting of any of its power cord.
 - Be sure to protect the display surface to prevent damage during the operations.

(2) Remove the retaining screws (6) on the rear cover.

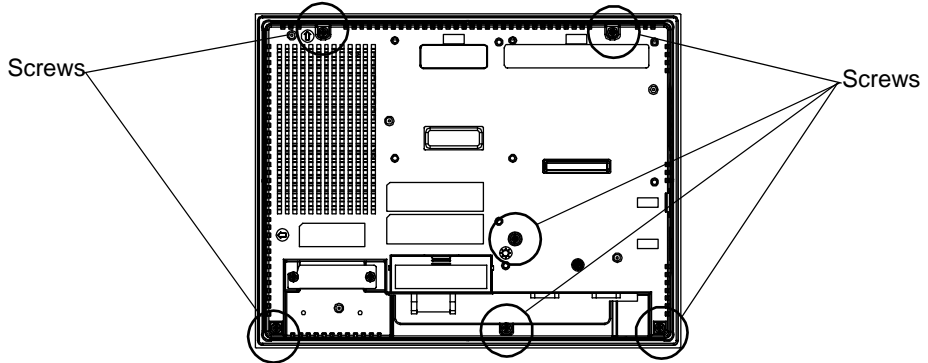

- IMPORTANT**
- Do not let the attachment screws fall inside the GP

(3) Open the rear cover carefully from the bottom of the unit to the top.

(4) Remove the setscrew (1) on the circuit board chassis.

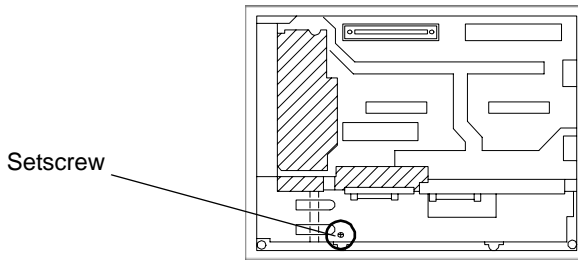

(5) Open the circuit board chassis, it's turn left to right.

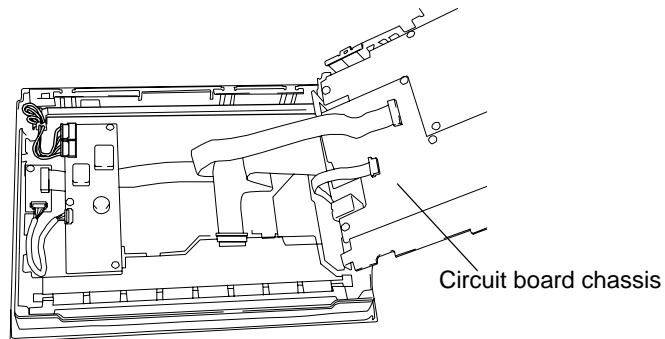

- IMPORTANT**
- A hot circuit board chassis can burn you. Be sure the chassis has cooled completely prior to replacing the backlights.

- (6) Disconnect the Backlight Unit cable from the connector on the inverter board, and then remove the cable from the cable clamp.

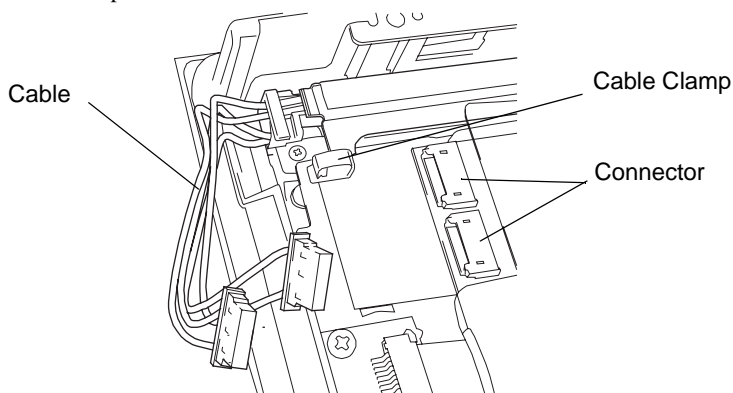

- (7) Remove the setscrew from the Backlight Unit.

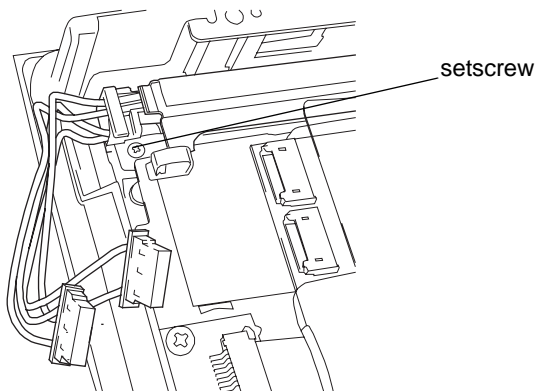
**NOTE**

- Use the Phillips screwdriver No.1.

- (8) Remove the Backlight Unit while sliding it along the groove.

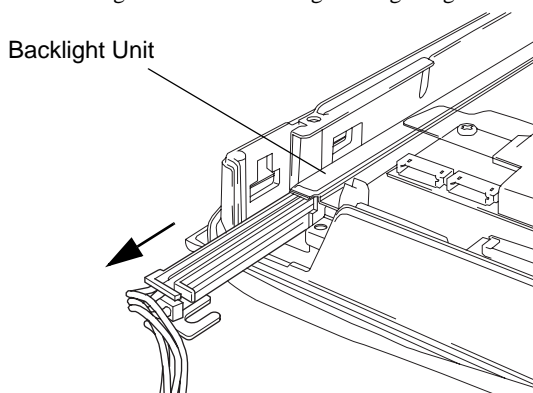

- (9) Insert a new Backlight Unit while sliding it along the groove.

IMPORTANT

- Be careful that no dust or dirt adheres to the backlight surface or to the backlight holder.
- Be careful not to soil the Backlight with moisture, oil content or finger prints; otherwise, the life duration of the Backlight will be shortened.

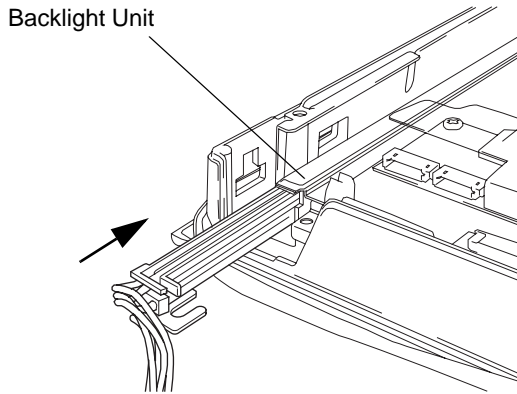

(10) Reattach the backlight unit's setscrew. The necessary torque is 0.196N•m.

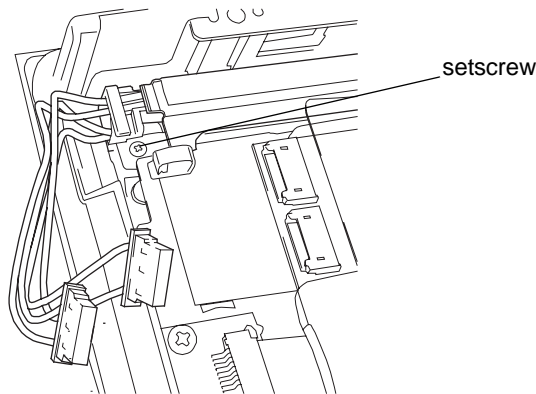

NOTE • Use the Phillips screwdriver No.1.

(11) Insert the Backlight Unit cable to the connector on the inverter board, and secure the cable with the cable clamp.

IMPORTANT • Be sure the cable is inserted completely into the backlight connector. Failure to do so may cause arcing, which can damage the connector.

(12) Return the circuit board chassis to the original position, and reattach the setscrew. The necessary torque is 0.5N•m.

(13) Return the rear face cover to the original position, and secure the cover in place using the mounting screws (6). The necessary torque is 0.5N•m.

IMPORTANT • The cable clamp is used to prevent the cable from being caught inside in the GP unit and possibly damaged. Be sure to insert the cable in the cable clamp around the cable before replacing the rear cover.

- If any of the screws is missing, check if it fell inside the GP unit's chassis. If the power is turned ON while a screw is inside, it may cause an accident or fire.

NOTE

- After backlight replacement is completed, turn the GP unit's power ON and check if the screen's display is normal. If the display is not correct, please contact the GP distributor from whom you purchased the backlight unit.

8.4.2 AGP-3500S

■Preparation

Please have the following ready beforehand.

- Replacement backlight (Model: PS501S-BU00 (Set of two))
- One pair of clean (preferably new) cotton gloves.
- Phillips screwdriver (no.2)

About the Backlight

GP units use a CFL, long-life type backlight. In a real world situation, the backlight may need to be replaced depending on the GP's operating environment. It is recommended that it be replaced periodically.

A backlight life refer to “■ Display Specifications (page 4-43)”, when the backlight is lit continuously (time required for brightness to fall to half its normal level.)

NOTE

- If the backlight or the display unit is damaged, the screen display will go out. Even if the screen goes out, however, there is a possibility that the touch panel is still operating correctly. Therefore, since any type of touch panel contact could have an unexpected or dangerous effect or result, be sure not to touch the screen when this condition occurs.

WARNING

[Electric shock]

- Whenever changing the backlight, be sure the GP's power cord has been disconnected and that the unit is cooled down.
- When the GP's power cord is connected and the GP is ON, high voltage runs through the wires in the backlight area do not touch them!

[Burn]

- When the GP's power has just been turned OFF, the backlight area is still very hot! Be sure to wear gloves to prevent being burned.

[Glass]

- The backlight is very fragile. Do not touch the glass tube directly or try to remove its power cord. If the glass tube breaks you may be injured.

■ Procedure for replacing the backlight

There are two backlight of AGP-3500S.

- (1) Unplug the power cord from the main power supply.

- IMPORTANT**
- Remove the GP unit from the equipment to which the unit has been incorporated, and work with the GP unit with the display surface facing downward. Be sure to perform the backlight changeover on a flat, level surface. This will prevent damage to the GP unit and the accidental cutting of any of its power cord.
 - Be sure to protect the display surface to prevent damage during the operations.

- (2) Remove the I/F cover and retaining screws (7) on the rear cover.

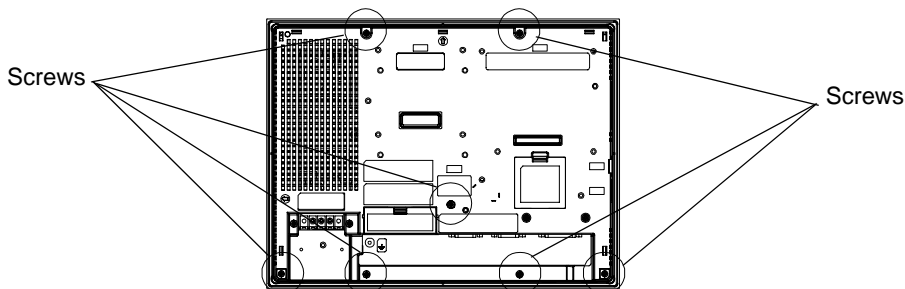

- IMPORTANT**
- Do not let the attachment screws fall inside the GP

- (3) The top face of the rear cover uses two (2) alignment tabs. Open the rear cover from the bottom of the unit to free these tabs.

- IMPORTANT**
- Be sure to open the cover from the bottom of the GP. Attempting to open the cover from the top of the GP could damage the alignment tabs.

- (4) Remove the setscrew (1) on the circuit board chassis.

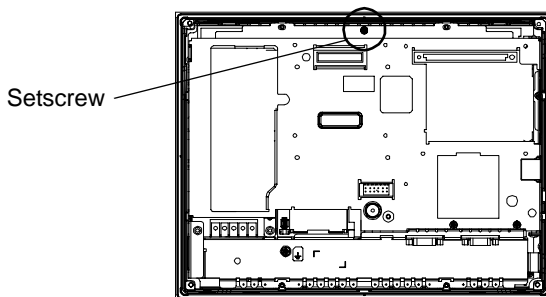

- NOTE**
- The Setscrews are not attached to all DC model of GP.

- (5) Open the circuit board chassis, it's turn left to right.

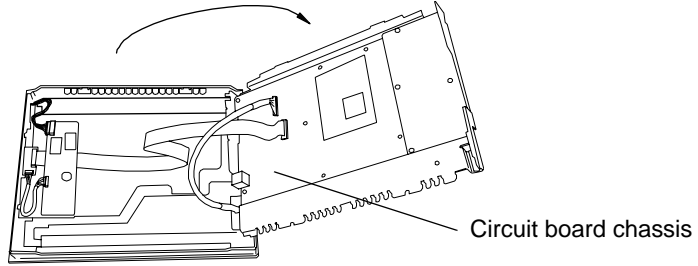

IMPORTANT

- A hot circuit board chassis can burn you. Be sure the chassis has cooled completely prior to replacing the backlights.

- (6) Disconnect the Backlight Unit cable from the connector on the inverter board, and then remove the cable from the cable clamp.

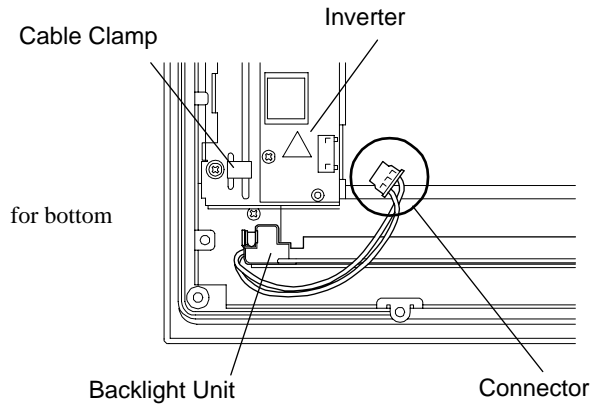

- (7) As shown here, push the backlight unit's attachment clip to the right to release the backlight unit.

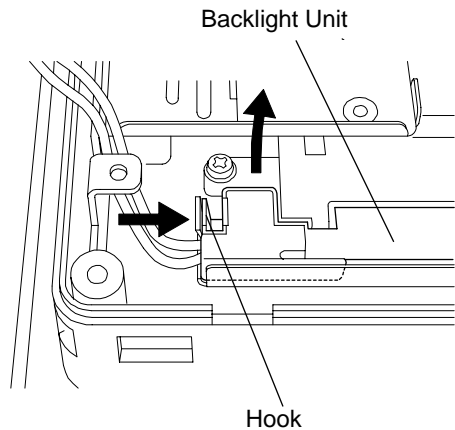

- (8) Insert the new lower backlight unit into the backlight holder as shown here. After the backlight is completely inserted and the attachment clip clicks into place, lower the unit into the GP.

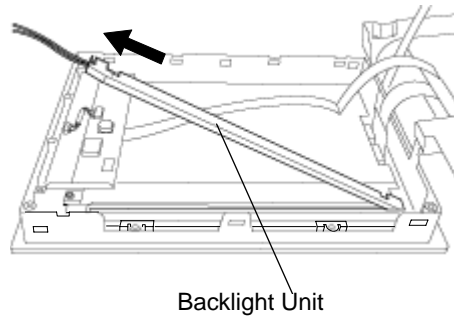

- IMPORTANT**
- Be careful that no dust or dirt adheres to the backlight surface or to the backlight holder. Be sure to handle the replacement backlight unit carefully, since it can be easily damaged or broken.

- (9) Confirm that the backlight unit is securely in place and reattach the backlight unit power connector.

- IMPORTANT**
- When replacing the Backlight unit, be sure not to catch any wiring on the edge of the unit. If a wire is caught and becomes cut, it could cause a fire.

- (10) Replace the upper backlight unit by repeating the procedures shown in steps (6) to (9).

- (11) Return the circuit board chassis to its original position and reattach the rear cover by reversing steps (1) to (5).

- IMPORTANT**
- The cable clamp is used to prevent the cable from being caught inside in the GP unit and possibly damaged. Be sure to insert the cable in the cable clamp around the cable before replacing the rear cover.
 - If any of the screws is missing, check if it fell inside the GP unit's chassis. If the power is turned ON while a screw is inside, it may cause an accident or fire.

- NOTE**
- After backlight replacement is completed, turn the GP unit's power ON and check if the screen's display is normal. If the display is not correct, please contact the GP distributor from whom you purchased the backlight unit.

8.4.3 AGP-3600T/3650T

■ Preparation

Please have the following ready beforehand.

- Replacement backlight (Model: CA3-BLU12-01)
- One pair of clean (preferably new) cotton gloves.
- Phillips screwdriver (no.2)

About the Backlight

GP units use a CFL, long-life type backlight. In a real world situation, the backlight may need to be replaced depending on the GP's operating environment. It is recommended that it be replaced periodically.

A backlight life refer to “■ Display Specifications (page 4-59)”, when the backlight is lit continuously (time required for brightness to fall to half its normal level.)

WARNING

[Electric shock]

- Whenever changing the backlight, be sure the GP's power cord has been disconnected and that the unit is cooled down.
- When the GP's power cord is connected and the GP is ON, high voltage runs through the wires in the backlight area do not touch them!

[Burn]

- When the GP's power has just been turned OFF, the backlight area is still very hot! Be sure to wear gloves to prevent being burned.

[Glass]

- The backlight is very fragile. Do not touch the glass tube directly or try to remove its power cord. If the glass tube breaks you may be injured.

■ Procedure for replacing the backlight

(1) Unplug the power cord from the main power supply.

IMPORTANT

- Remove the GP unit from the equipment to which the unit has been incorporated, and work with the GP unit with the display surface facing downward. Be sure to perform the backlight changeover on a flat, level surface. This will prevent damage to the GP unit and the accidental cutting of any of its power cord.
- Be sure to protect the display surface to prevent damage during the operations.

- (2) Remove the retaining screws (7) on the rear cover

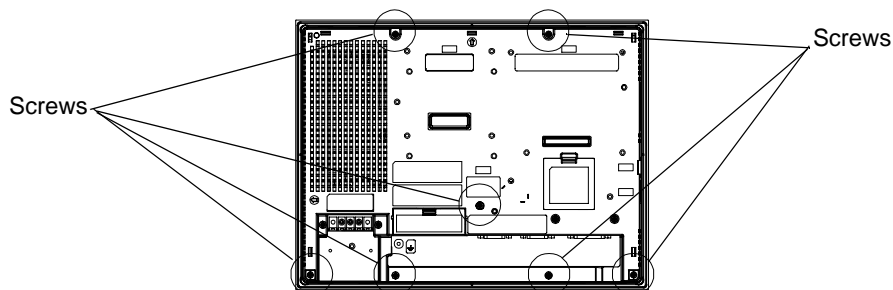

IMPORTANT • Do not let the attachment screws fall inside the GP

- (3) Remove the setscrew (1) on the circuit board chassis.

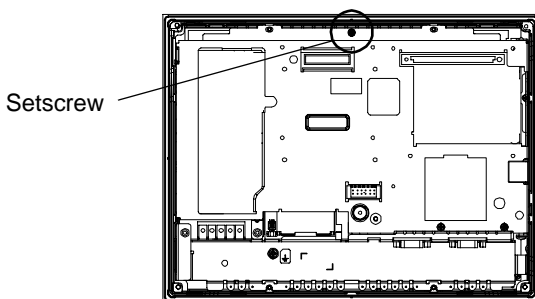

NOTE • The Setscrews are not attached to all DC model of GP.

- (4) Open the circuit board chassis, it's turn left to right.

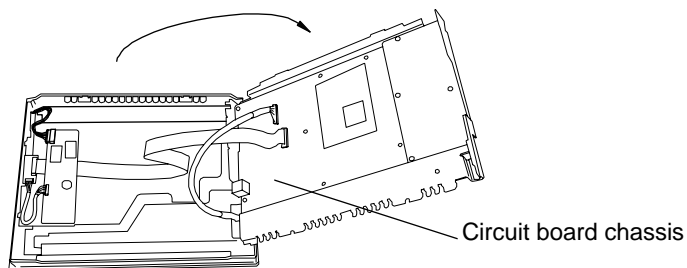

IMPORTANT • A hot circuit board chassis can burn you. Be sure the chassis has cooled completely prior to replacing the backlights.

- (5) Disconnect the Backlight Unit cable from the connector on the inverter board, and then remove the cable from the cable clamp.

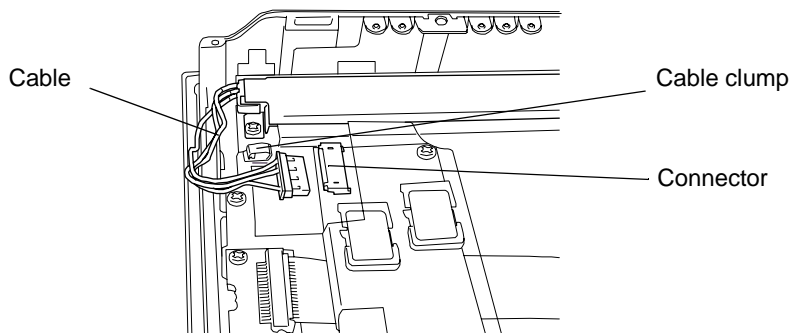

- (6) Remove the Setscrew from the Backlight Unit

Setscrew for the Backlight Unit

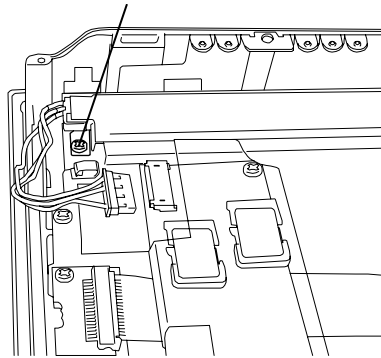

- (7) Lift the edge of the Backlight Unit, and remove the unit while sliding it along the groove

Backlight Unit

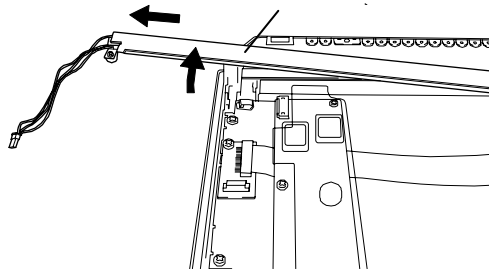

- (8) Insert a new Backlight Unit while sliding it along the groove.

IMPORTANT

- Be careful that no dust or dirt adheres to the backlight surface or to the backlight holder.
- Be careful not to soil the Backlight with moisture, oil content or finger prints; otherwise, the life duration of the Backlight will be shortened.

Backlight Unit

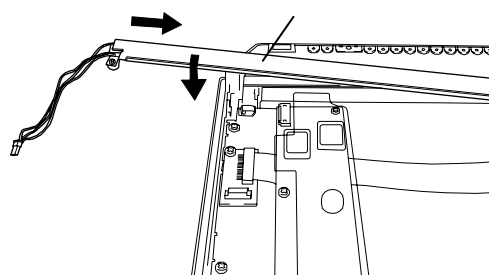

- (9) Fasten the setscrew for the backlight unit. The necessary torque is 0.147N•m.

- (10) Insert the Backlight Unit cable to the connector on the inverter board, and secure the cable with the cable clamp.

IMPORTANT

- Be sure the cable is inserted completely into the backlight connector. Failure to do so may cause arcing, which can damage the connector.

- (11) Return the circuit board chassis to the original position.

- (12) Return the rear face cover to the original position, and secure the cover in place using the mounting screws (7). The necessary torque is 0.5N•m.

IMPORTANT

- The cable clamp is used to prevent the cable from being caught inside in the GP unit and possibly damaged. Be sure to insert the cable in the cable clamp around the cable before replacing the rear cover.
- If any of the screws is missing, check if it fell inside the GP unit's chassis. If the power is turned ON while a screw is inside, it may cause an accident or fire.

NOTE

- After backlight replacement is completed, turn the GP unit's power ON and check if the screen's display is normal. If the display is not correct, please contact the GP distributor from whom you purchased the backlight unit.

8.4.4 AGP-3750T

■ Preparation

Please have the following ready beforehand.

- Replacement backlight (Model: CA3-BLU15-01 (Set of two))
- One pair of clean (preferably new) cotton gloves.
- Phillips screwdriver (no.2)

About the Backlight

GP units use a CFL, long-life type backlight. In a real world situation, the backlight may need to be replaced depending on the GP's operating environment. It is recommended that it be replaced periodically.

A backlight life refer to “■ Display Specifications (page 4-72)”, when the backlight is lit continuously (time required for brightness to fall to half its normal level.)

WARNING

[Electric shock]

- Whenever changing the backlight, be sure the GP's power cord has been disconnected and that the unit is cooled down.
- When the GP's power cord is connected and the GP is ON, high voltage runs through the wires in the backlight area do not touch them!

[Burn]

- When the GP's power has just been turned OFF, the backlight area is still very hot! Be sure to wear gloves to prevent being burned.

[Glass]

- The backlight is very fragile. Do not touch the glass tube directly or try to remove its power cord. If the glass tube breaks you may be injured.

■ Procedure for replacing the backlight

There are two backlight of AGP-3750T.

- (1) Unplug the power cord from the main power supply.

IMPORTANT

- Remove the GP unit from the equipment to which the unit has been incorporated, and work with the GP unit with the display surface facing downward. Be sure to perform the backlight changeover on a flat, level surface. This will prevent damage to the GP unit and the accidental cutting of any of its power cord.
- Be sure to protect the display surface to prevent damage during the operations.

- (2) Remove the retaining screws (6) on the rear cover, and detach the cover from the main unit.

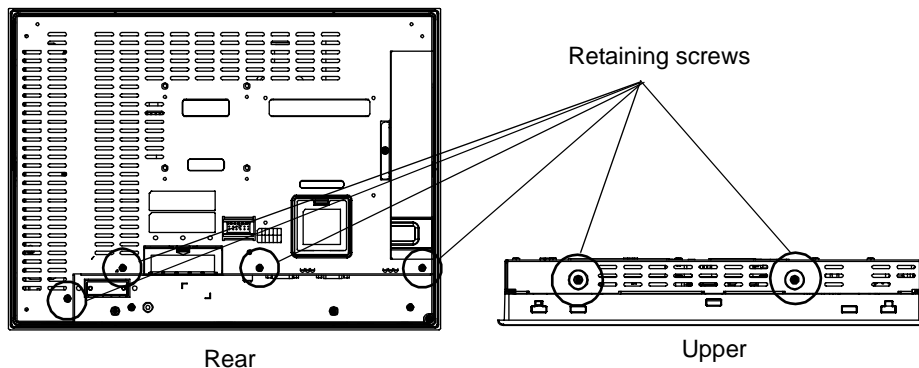

IMPORTANT • Do not let the attachment screws fall inside the GP.

- (3) Pull out cable from inverter insulating sheet, and remove from cable clamp.

Remove cable from backlight connector on inverter circuit board.

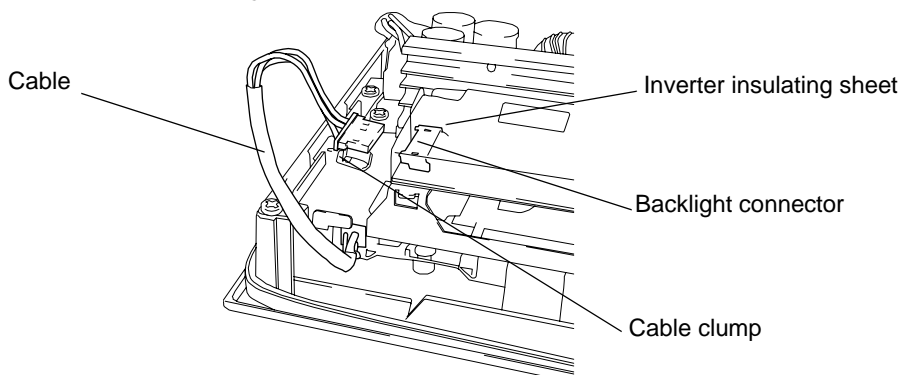

IMPORTANT • A hot circuit board chassis can burn you. Be sure the chassis has cooled completely prior to replacing the backlights.

- (4) Insert shuttle driver to circular hole, and remove backlight setscrew. There are two circular hole.

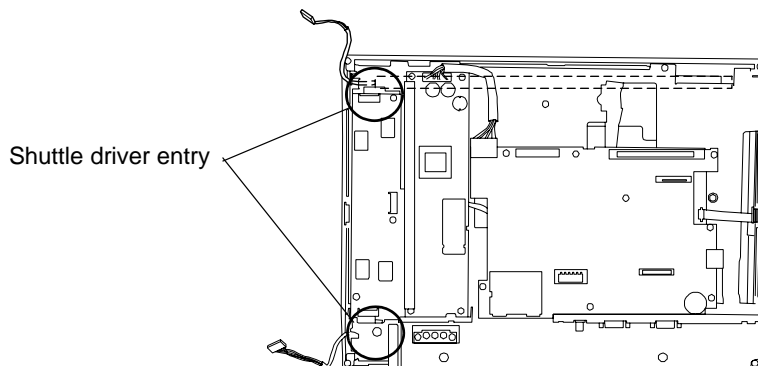

- (5) Draw out the cable in the direction of an arrow. Creep out backlight unit from backlight unit slot.

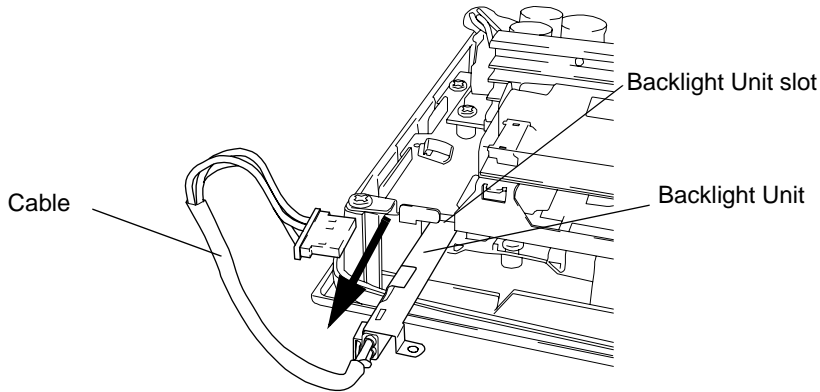

IMPORTANT • Replace backlight the whole backlight unit.

- (6) Insert a new backlight unit in backlight unit slot.

Secure the backlight setscrew. The necessary torque is 0.147N•m. (The procedure of opposite to procedure 4.)

- (7) Insert the cable to backlight connector.

Secure the cable with the cable clamp.

(The procedure of opposite to procedure 3.)

IMPORTANT • Be sure the cable is inserted completely into the backlight connector. Failure to do so may cause arcing, which can damage the connector.

- Backlight has used 1 each of top and bottom LCD. The case of exchange 2 please exchange simultaneously.

- (8) Return the rear face cover to the original position, and secure the cover in place using the mounting screws (6). The necessary torque is 0.5N•m

IMPORTANT • The cable clamp is used to prevent the cable from being caught inside in the GP unit and possibly damaged. Be sure to insert the cable in the cable clamp around the cable before replacing the rear cover.

- If any of the screws is missing, check if it fell inside the GP unit's chassis. If the power is turned ON while a screw is inside, it may cause an accident or fire.

NOTE • After backlight replacement is completed, turn the GP unit's power ON and check if the screen's display is normal. If the display is not correct, please contact the GP distributor from whom you purchased the backlight unit.