



Q/QnA Serial Communication Driver

1	System Configuration.....	3
2	Selection of External Device	7
3	Example of Communication Setting.....	8
4	Setup Items.....	23
5	Cable Diagram	28
6	Range of Supported Device Address.....	40
7	Device Code and Address Code.....	42
8	Error Messages.....	43

Introduction

This manual describes how to connect the Display and the External Device (target PLC).

In this manual, the connection procedure will be described by following the below sections:

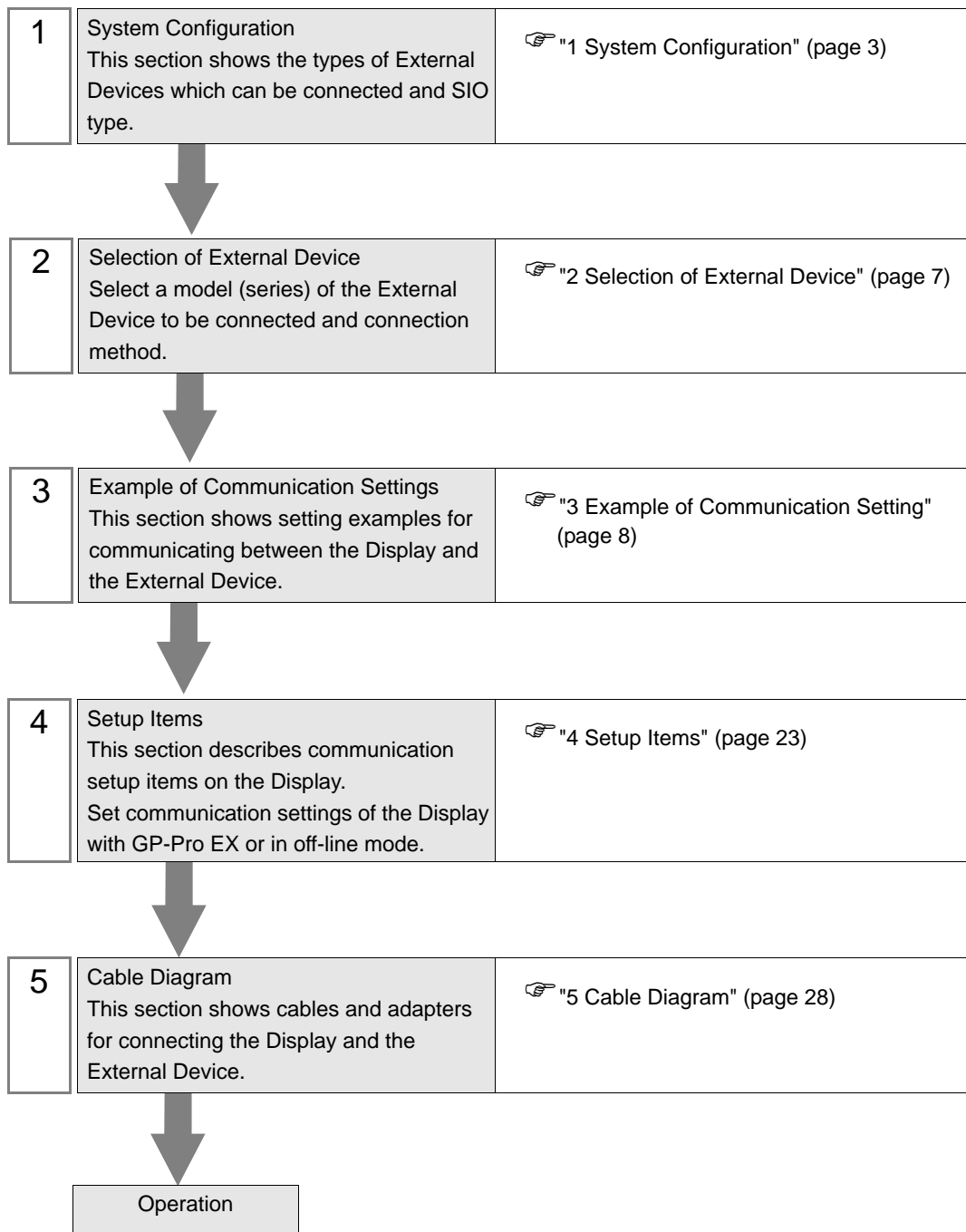

1 System Configuration

The system configuration in the case when the External Device of Mitsubishi Electric Corp. and the Display are connected is shown.

Series	CPU	Link I/F	SIO Type	Example of Communication Settings	Cable Diagram	
MELSEC Q	Q02CPU	QJ71C24	RS232C	Setting Example 3 (page 14)	Cable Diagram 1 (page 28)	
	Q02HCPU	QJ71C24-R2				
	Q06HCPU	QJ71C24N				
	Q12HCPU	QJ71C24N-R2				
	Q25HCPU		RS422/485 (4wire)	Setting Example 4 (page 17)	Cable Diagram 2 (page 29)	
	Q00JCPU	QJ71C24				
	Q00CPU	QJ71C24N				
	Q01CPU	QJ71C24N-R4				
Q00CPU	Q01CPU	RS232C connector on CPU	RS232C	Setting Example 5 (page 20)	Cable Diagram 3 (page 34)	
MELSEC QnA	Q2ASCPU	A1SJ71QC24	RS232C	Setting Example 1 (page 8)	Cable Diagram 1 (page 28)	
	Q2ASCPU-S1	A1SJ71QC24N				
	Q2ASHCPU	A1SJ71QC24-R2				
	Q2ASHCPU-S1	A1SJ71QC24N-R2				
		A1SJ71QC24	A1SJ71QC24N	RS422/485 (4wire)	Setting Example 2 (page 11)	Cable Diagram 2 (page 29)
	Q2ACPU	AJ71QC24	RS232C	Setting Example 1 (page 8)	Cable Diagram 4 (page 35)	
	Q2ACPU-S1	AJ71QC24N				
	Q3ACPU	AJ71QC24-R2				
	Q4ACPU	AJ71QC24N-R2				
	Q4ARCPU	AJ71QC24	AJ71QC24N	RS422/485 (4wire)	Setting Example 2 (page 11)	Cable Diagram 2 (page 29)
				RS422/485 (4wire) (when using CH1)	Setting Example 2 (page 11)	Cable Diagram 5 (page 36)
				RS422/485 (4wire) (when using CH2)	Setting Example 2 (page 11)	Cable Diagram 2 (page 29)

■ Connection Configuration

- 1:1 Connection

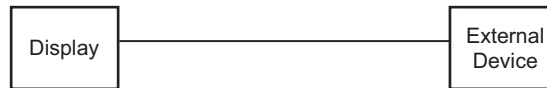

- 1:n Connection 1

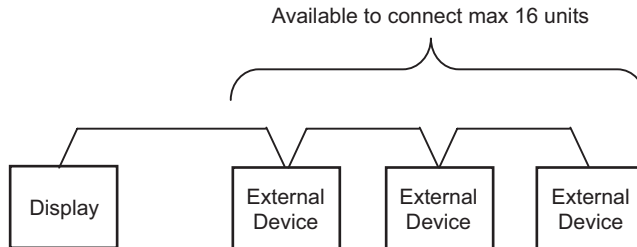

- 1:n Connection (when communicating via network)

You can access other stations via MELSECNET/H, MELSECNET/10, Ethernet or Q Series C24 unit. Note that you can access only the source station when using Q00CPU or the RS232C connector on Q00CPU.

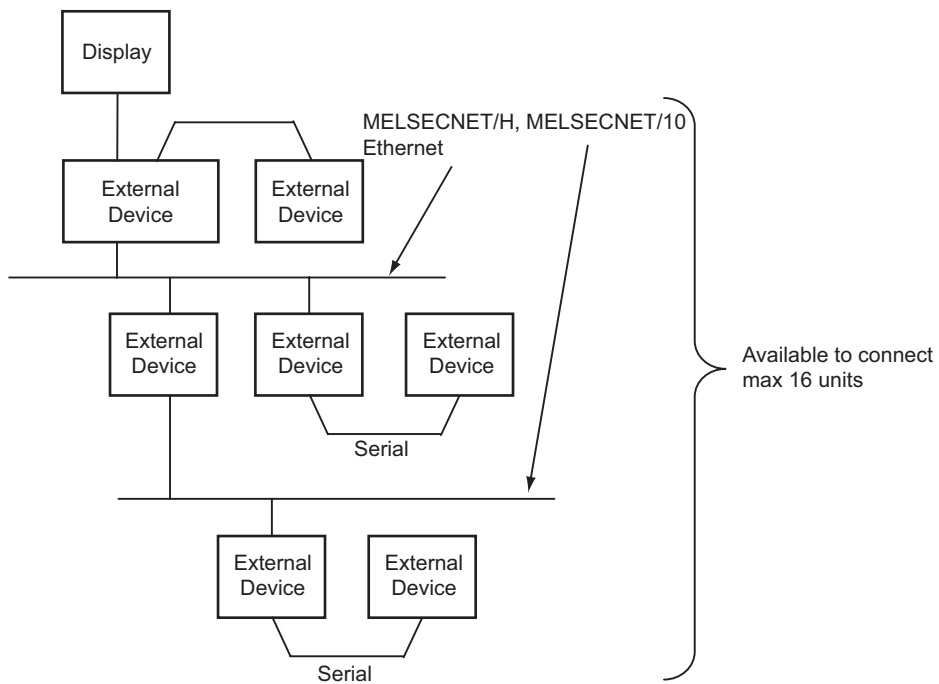

NOTE

- In case of communication via network, please set larger value than the response monitoring time of the relay station for timeout settings.

■ COM Port of IPC

When connecting IPC with External Device, the COM port which can be used changes with series and SIO type. Please refer to the manual of IPC for details.

Usable port

Series	Usable port		
	RS-232C	RS-422/485(4 wire)	RS-422/485(2 wire)
PS-2000B	COM1 ^{*1} , COM2, COM3 ^{*1} , COM4	-	-
PS-3650A, PS-3651A	COM1 ^{*1}	-	-
PS-3700A (Pentium®4-M) PS-3710A	COM1 ^{*1} , COM2 ^{*1} , COM3 ^{*2} , COM4	COM3 ^{*2}	COM3 ^{*2}
PS-3711A	COM1 ^{*1} , COM2 ^{*2}	COM2 ^{*2}	COM2 ^{*2}

*1 The RI/5V can be switched. Please switch with the change switch of IPC.

*2 It is necessary to set up the SIO type with the Dip switch. Please set up as follows according to SIO type to be used.

Dip switch setting: RS-232C

Dip switch	Setting	Description
1	OFF	Reserve (always OFF)
2	OFF	SIO type: RS-232C
3	OFF	
4	OFF	Output mode of SD (TXD) data: Always output
5	OFF	Terminal resistance (220Ω) insertion to SD (TXD): None
6	OFF	Terminal resistance (220Ω) insertion to RD (RXD): None
7	OFF	Short-circuit of SDA (TXA) and RDA (RXA): Does not Exist
8	OFF	Short-circuit of SDB (TXB) and RDB (RXB): Does not Exist
9	OFF	RS (RTS) Auto control mode: Disable
10	OFF	

Dip switch setting: RS-422/485 (4 wire)

Dip switch	Setting	Description
1	OFF	Reserve (always OFF)
2	ON	SIO type: RS-422/485
3	ON	
4	OFF	Output mode of SD (TXD) data: Always output
5	OFF	Terminal resistance (220Ω) insertion to SD (TXD): None
6	OFF	Terminal resistance (220Ω) insertion to RD (RXD): None
7	OFF	Short-circuit of SDA (TXA) and RDA (RXA): Does not Exist
8	OFF	Short-circuit of SDB (TXB) and RDB (RXB): Does not Exist
9	OFF	RS (RTS) Auto control mode: Disable
10	OFF	

Dip switch setting: RS-422/485 (2 wire)

Dip switch	Setting	Description
1	OFF	Reserve (always OFF)
2	ON	SIO type: RS-422/485
3	ON	
4	OFF	Output mode of SD (TXD) data: Always output
5	OFF	Terminal resistance (220Ω) insertion to SD (TXD): None
6	OFF	Terminal resistance (220Ω) insertion to RD (RXD): None
7	ON	Short-circuit of SDA (TXA) and RDA (RXA): Exist
8	ON	Short-circuit of SDB (TXB) and RDB (RXB): Exist
9	ON	RS (RTS) Auto control mode: Enable
10	ON	

2 Selection of External Device

Select the External Device to be connected to the Display.

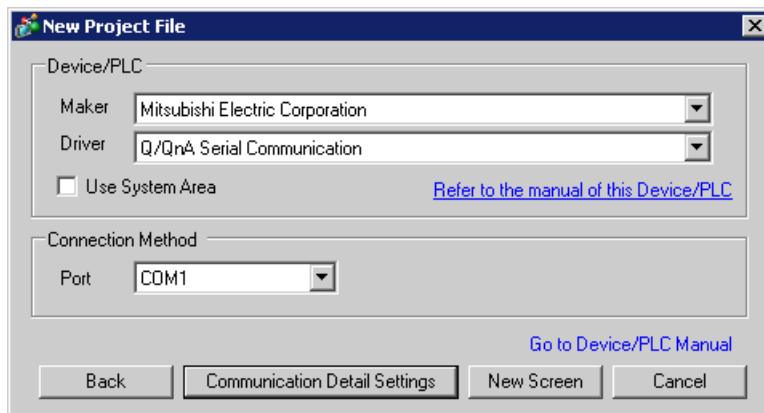

Setup Items	Setup Description
Maker	Select the maker of the External Device to be connected. Select "Mitsubishi Electric Corporation".
Driver	Select a model (series) of the External Device to be connected and connection method. Select "Q/QnA Serial Communication". Check the External Device which can be connected in "Q/QnA Serial Communication" in system configuration. ☞ "1 System Configuration" (page 3)
Use System Area	Check this option when you synchronize the system data area of Display and the device (memory) of External Device. When synchronized, you can use the ladder program of External Device to switch the display or display the window on the display. Cf. GP-Pro EX Reference Manual "Appendix 1.4 LS Area (only for direct access method)" This can be also set with GP-Pro EX or in off-line mode of Display. Cf. GP-Pro EX Reference Manual " 5.14.6 Setting Guide of [System Setting Window]■[Main Unit Settings] Settings Guide◆System Area Setting" Cf. Maintenance/Troubleshooting "2.14.1 Settings common to all Display models◆System Area Settings"
Port	Select the Display port to be connected to the External Device.

3 Example of Communication Setting

Examples of communication settings of the Display and the External Device, recommended by Pro-face, are shown.

3.1 Setting Example 1

■ Setting of GP-Pro EX

◆ Communication Settings

To display the setting screen, select [Device/PLC Settings] from [System setting window] in workspace.

Device/PLC 1

Summary [Change Device/PLC](#)

Maker Series Port

Text Data Mode [Change](#)

Communication Settings

SIQ Type RS232C RS422/485(2wire) RS422/485(4wire)

Speed

Data Length 7 8

Parity NONE EVEN ODD

Stop Bit 1 2

Flow Control NONE ER(DTR/CTS) XON/XOFF

Timeout (sec)

Retry

Wait To Send (ms)

RI / VCC RI VCC

In the case of RS232C, you can select the 9th pin to RI (Input) or VCC (5V Power Supply). If you use the Digital's RS232C Isolation Unit, please select it to VCC.

[Default](#)

Device-Specific Settings

Allowable No. of Device/PLCs 16 Unit(s)

No.	Device Name	Settings
1	PLC1	Station No.=0,Network No.=0,PC No.=255,Request destination module I/O N

NOTE

- When using A1SJ71QC24N, A1SJ71QC24N-R2, AJ71QC24N or AJ71QC24N-R2, you can set the "Speed" up to 115200.

◆ Device Setting

To display the setting screen, click  ([Setting]) of External Device you want to set from [Device-Specific Settings] of [Device/PLC Settings].

When you connect multiple External Device, click  from [Device-Specific Settings] of [Device/PLC Settings] to add another External Device.

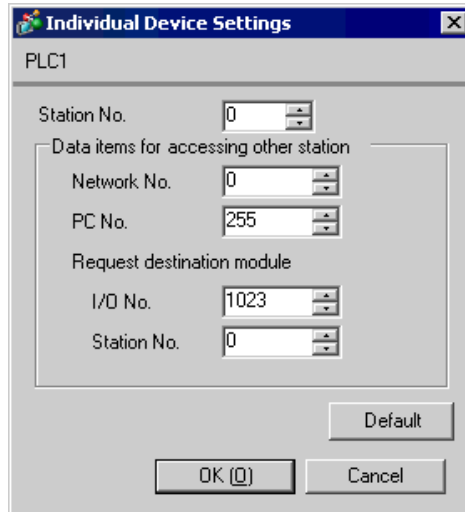

◆ Important Item

When you use 2 types of interface in A1SJ71QC24N, A1SJ71QC24N-R2, AJ71QC24N or AJ71QC24N-R2, please set the total speed of CH1 and CH2 to 115200 or less.

■ Setting of External Device

Use the front switch of the computer link unit to set the communication settings as below.

DIP Switch	Settings	Setup Description
SW1	OFF	Operation Setting = Independent Operation
SW2	ON	Data Length = 8 bits
SW3	ON	With/Without Parity = With
SW4	OFF	Parity = Odd parity
SW5	OFF	Stop Bit = 1 bit
SW6	ON	Sum Check = Enable
SW7	ON	Write during RUN = Enable
SW8	ON	Setting change Enable/Disable = Enable
SW9	OFF	Transmission Speed = 19200
SW10	ON	
SW11	ON	
SW12	OFF	

NOTE • When using A1SJ71QC24N, A1SJ71QC24N-R2, AJ71QC24N or AJ71QC24N-R2, you can set the "Speed" up to 115200.

- Station Setting Switch

Setting Switch	Settings
x 10	0
x 1	0

- Mode Setting Switch

Setting Switch	Settings
MODE (CH1)	5
MODE (CH2)	5

◆ Important Item

When you use 2 types of interface in A1SJ71QC24N, A1SJ71QC24N-R2, AJ71QC24N or AJ71QC24N-R2, please set the total speed of CH1 and CH2 to 115200 or less.

3.2 Setting Example 2

■ Setting of GP-Pro EX

◆ Communication Settings

To display the setting screen, select [Device/PLC Settings] from [System setting window] in workspace.

Device/PLC 1

Summary [Change Device/PLC](#)

Maker Series Port

Text Data Mode [Change](#)

Communication Settings

RS232C
 RS422/485(2wire)
 RS422/485(4wire)

Speed

Data Length 7 8

Parity NONE EVEN ODD

Stop Bit 1 2

Flow Control NONE ER(DTR/CTS) XON/XOFF

Timeout (sec)

Retry

Wait To Send (ms)

RI / VCC
 RI
 VCC

In the case of RS232C, you can select the 9th pin to RI (Input) or VCC (5V Power Supply). If you use the Digital's RS232C Isolation Unit, please select it to VCC.

[Default](#)

Device-Specific Settings

Allowable No. of Device/PLCs 16 Unit(s)

No.	Device Name	Settings
1	PLC1	Station No.=0,Network No.=0,PC No.=255,Request destination module I/O N

NOTE

- When using A1SJ71QC24N, AJ71QC24N or AJ71QC24N-R4, you can set the "Speed" up to 115200.

◆ Device Setting

To display the setting screen, click  ([Setting]) of External Device you want to set from [Device-Specific Settings] of [Device/PLC Settings].

When you connect multiple External Device, click  from [Device-Specific Settings] of [Device/PLC Settings] to add another External Device.

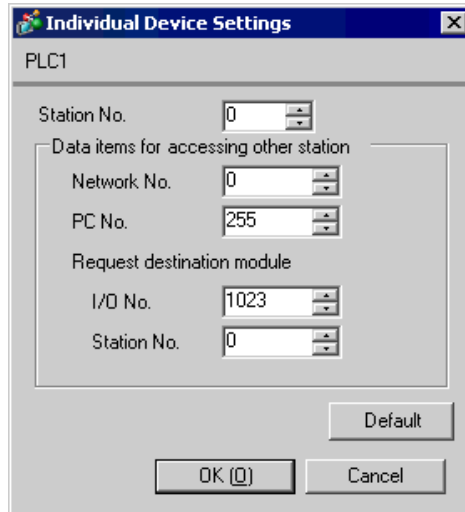

◆ Important Item

When you use 2 types of interface in A1SJ71QC24N, AJ71QC24N or AJ71QC24N-R4, please set the total speed of CH1 and CH2 to 115200 or less.

■ Setting of External Device

Use the front switch of the computer link unit to set the communication settings as below.

DIP Switch	Settings	Setup Description
SW1	OFF	Operation Setting = Independent Operation
SW2	ON	Data Length = 8 bits
SW3	ON	With/Without Parity = With
SW4	OFF	Parity = Odd parity
SW5	OFF	Stop Bit = 1 bit
SW6	ON	Sum Check = Enable
SW7	ON	Write during RUN = Enable
SW8	ON	Setting change Enable/Disable = Enable
SW9	OFF	Transmission Speed = 19200
SW10	ON	
SW11	ON	
SW12	OFF	

NOTE

- When using A1SJ71QC24N, AJ71QC24N or AJ71QC24N-R4, you can set the "Speed" up to 115200.

- Station Setting Switch

Setting Switch	Settings
x 10	0
x 1	0

- Mode Setting Switch

Setting Switch	Settings
MODE (CH1)	5
MODE (CH2)	5

◆ Important Item

When you use 2 types of interface in A1SJ71QC24N, AJ71QC24N or AJ71QC24N-R4, please set the total speed of CH1 and CH2 to 115200 or less.

3.3 Setting Example 3

■ Setting of GP-Pro EX

◆ Communication Settings

To display the setting screen, select [Device/PLC Settings] from [System setting window] in workspace.

Device/PLC 1

Summary [Change Device/PLC](#)

Maker Series Port

Text Data Mode [Change](#)

Communication Settings

SID Type RS232C RS422/485(2wire) RS422/485(4wire)
 Speed
 Data Length 7 8
 Parity NONE EVEN ODD
 Stop Bit 1 2
 Flow Control NONE ER(DTR/CTS) XON/XOFF
 Timeout (sec)
 Retry
 Wait To Send (ms)

RI / VCC RI VCC
 In the case of RS232C, you can select the 9th pin to RI (Input) or VCC (5V Power Supply). If you use the Digital's RS232C Isolation Unit, please select it to VCC.

Device-Specific Settings

Allowable No. of Device/PLCs 16 Unit(s)

No.	Device Name	Settings
1	PLC1	Station No.=0,Network No.=0,PC No.=255,Request destination module I/O N

◆ Device Setting

To display the setting screen, click  ([Setting]) of External Device you want to set from [Device-Specific Settings] of [Device/PLC Settings].

When you connect multiple External Device, click  from [Device-Specific Settings] of [Device/PLC Settings] to add another External Device.

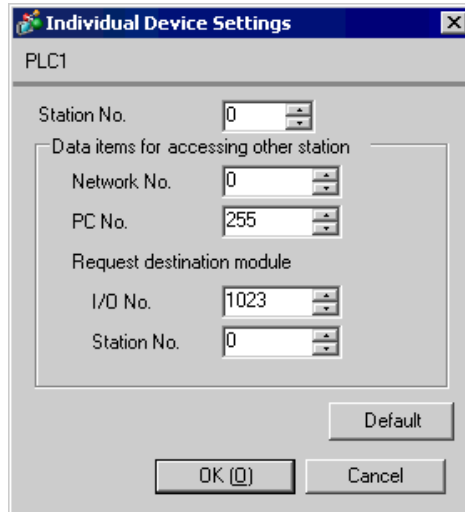
**◆ Important Item**

When you use 2 types of interface in QJ71C24 or QJ71C24-R2, please set the total speed of CH1 and CH2 to 115200 or less.

■ Setting of External Device

Use the GPP function software by Mitsubishi Electric Corporation to perform the communication settings as below.

- (1) Double-click [PC Parameter] from [Parameter] to select the [I/O Assign Setting] tab.
- (2) Click [Type] to select [Intelligent].
- (3) Click [Switch Settings] and set as below.

Setting Switch	Setting Value	Setup Description
Switch 1	07E6	19200/8/With/Odd/1
Switch 2	0005	Mode = Form 5
Switch 5	0000	Station No. = 0

NOTE • Please refer to the manual of the External Device for more detail on setting description.

◆ Important Item

When you use 2 types of interface in QJ71C24 or QJ71C24-R2, please set the total speed of CH1 and CH2 to 115200 or less.

3.4 Setting Example 4

■ Setting of GP-Pro EX

◆ Communication Settings

To display the setting screen, select [Device/PLC Settings] from [System setting window] in workspace.

Device/PLC 1

Summary [Change Device/PLC](#)

Maker Series Port

Text Data Mode [Change](#)

Communication Settings

SIO Type RS232C RS422/485(2wire) RS422/485(4wire)

Speed

Data Length 7 8

Parity NONE EVEN ODD

Stop Bit 1 2

Flow Control NONE ER(DTR/CTS) XON/XOFF

Timeout (sec)

Retry

Wait To Send (ms)

RI / VCC RI VCC

In the case of RS232C, you can select the 9th pin to RI (Input) or VCC (5V Power Supply). If you use the Digital's RS232C Isolation Unit, please select it to VCC.

Device-Specific Settings

Allowable No. of Device/PLCs 16 Unit(s)

No.	Device Name	Settings
1	PLC1	Station No.=0,Network No.=0,PC No.=255,Request destination module I/O N

◆ Device Setting

To display the setting screen, click  ([Setting]) of External Device you want to set from [Device-Specific Settings] of [Device/PLC Settings].

When you connect multiple External Device, click  from [Device-Specific Settings] of [Device/PLC Settings] to add another External Device.

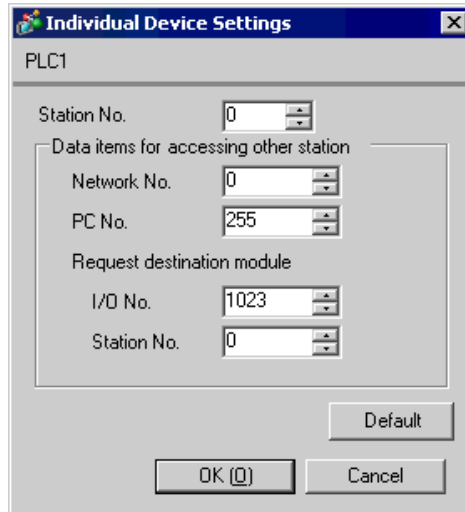

◆ Important Item

When you use 2 types of interface in QJ71C24, please set the total speed of CH1 and CH2 to 115200 or less.

■ Setting of External Device

Use the GPP function software by Mitsubishi Electric Corporation to perform the communication settings as below.

- (1) Double-click [PC Parameter] from [Parameter] to select the [I/O Assign Setting] tab.
- (2) Click [Type] to select [Intelligent].
- (3) Click [Switch Settings] and set as below.

Setting Switch	Setting Value	Setup Description
Switch 3	07E6	19200/8/With/Odd/1
Switch 4	0005	Mode = Form 5
Switch 5	0000	Station No. = 0

NOTE • Please refer to the manual of the External Device for more detail on setting description.

◆ Important Item

When you use 2 types of interface in QJ71C24, please set the total speed of CH1 and CH2 to 115200 or less.

3.5 Setting Example 5

■ Setting of GP-Pro EX

◆ Communication Settings

To display the setting screen, select [Device/PLC Settings] from [System setting window] in workspace.

Device/PLC 1

Summary [Change Device/PLC](#)

Maker Series Port

Text Data Mode [Change](#)

Communication Settings

SID Type RS232C RS422/485(2wire) RS422/485(4wire)
 Speed
 Data Length 7 8
 Parity NONE EVEN ODD
 Stop Bit 1 2
 Flow Control NONE ER(DTR/CTS) XON/XOFF
 Timeout (sec)
 Retry
 Wait To Send (ms)

RI / VCC RI VCC
 In the case of RS232C, you can select the 9th pin to RI (Input) or VCC (5V Power Supply). If you use the Digital's RS232C Isolation Unit, please select it to VCC.

Device-Specific Settings

Allowable No. of Device/PLCs 16 Unit(s)

No.	Device Name	Settings
1	PLC1	Station No.=0,Network No.=0,PC No.=255,Request destination module I/O N

◆ Device Setting

To display the setting screen, click  ([Setting]) of External Device you want to set from [Device-Specific Settings] of [Device/PLC Settings].

When you connect multiple External Device, click  from [Device-Specific Settings] of [Device/PLC Settings] to add another External Device.

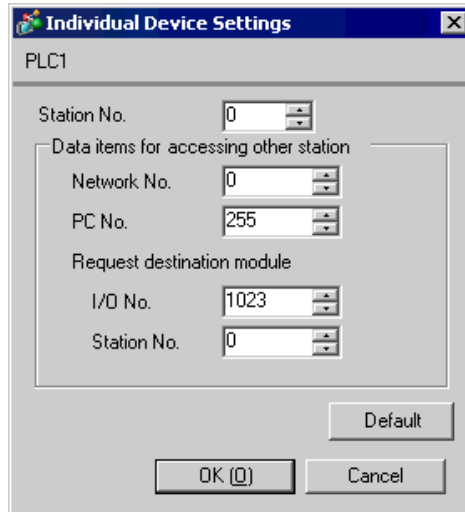

Individual Device Settings

PLC1

Station No. 0

Data items for accessing other station

Network No. 0

PC No. 255

Request destination module

I/O No. 1023

Station No. 0

Default

OK (O) Cancel

■ Setting of External Device

Use the GPP function software by Mitsubishi Electric Corporation to perform the communication settings as below.

(1) Double-click [PC Parameter] from [Parameter] to select [Serial Communication Settings].

(2) Set as below.

Setup Items	Settings
Use Serial Communication Function ^{*1}	Use
Baud Rate	19.2Kbps
Sum Check	Enable
Transmission Wait Time	No Wait
Write Setting during RUN	Enable

*1 Check the checkbox to make other setting items become available to set.

4 Setup Items

Set communication settings of the Display with GP-Pro EX or in off-line mode of the Display.

The setting of each parameter must be identical to that of External Device.

☞ "3 Example of Communication Setting" (page 8)

4.1 When setting with GP-Pro EX

■ Communication Settings

To display the setting screen, select [Device/PLC Settings] from [System setting window] in workspace.

Setup Items	Setup Description
SIO Type	Select the SIO type to communicate with the External Device.
Speed	Select speed between the External Device and the Display.
Data Length	Select data length.
Parity	Select how to check parity.
Stop Bit	Select stop bit length.
Flow Control	Select the communication control method to prevent overflow of transmission and reception data.
Timeout	Use an integer from 1 to 127 to enter the time (s) for which the Display waits for the response from the External Device. NOTE In case of communicating via network, please set larger value than the response monitoring time of the relay station for timeout settings.
Retry	In case of no response from the External Device, use an integer from 0 to 255 to enter how many times the Display retransmits the command.
Wait To Send	Use an integer from 0 to 255 to enter standby time (ms) for the Display from receiving packets to transmitting next commands.

Setup Items	Setup Description
RI/VCC	You can switch RI/VCC of the 9th pin when you select RS232C for SIO type. It is necessary to change RI/5V by changeover switch of IPC when connect with IPC. Please refer to the manual of the IPC for more detail.

■ Device Setting

To display the setting screen, click  ([Setting]) of External Device you want to set from [Device-Specific Settings] of [Device/PLC Settings].

When [Allowable No. of Device/PLCs] is multiple, click  from [Device-Specific Settings] of [Device/PLC Settings] to add another External Device.

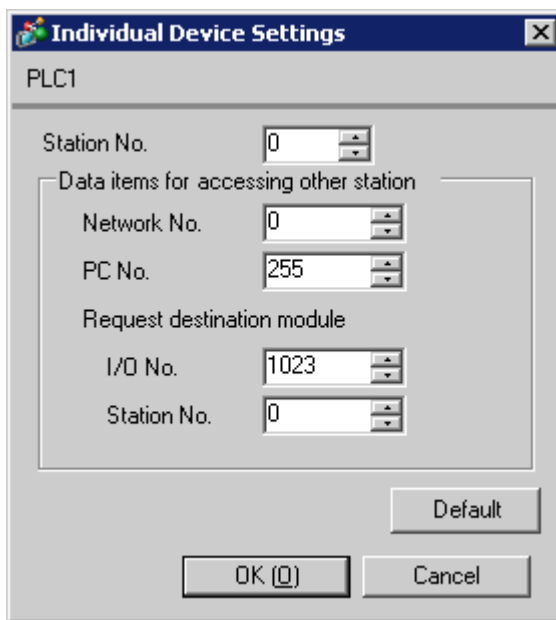

Setup Items	Setup Description
Station No.	Use an integer from 0 to 31 to enter the station number of the External Device directly connected to the Display.
Network No.	Set when you communicate via network. Use an integer from 0 to 239 to enter network No. of the External Device to communicate. If you do not communicate via network, enter 0.
PC No.	Set when you communicate via network. Use an integer from 0 to 64 to enter PC No. of the External Device to communicate. If you do not communicate via network, enter 255.
Request destination module I/O No.	Set when you communicate via network. Use an integer from 0 to 511 to enter I/O No. of the External Device to communicate. If you do not communicate via network, enter 1023.
Request destination module Station No.	Set when you communicate via network. Use an integer from 0 to 31 to enter station No. of the External Device to communicate. If you do not communicate via network, enter 0.

4.2 Communication Settings in Off-line Mode

NOTE

- Please refer to Maintenance/Troubleshooting for more information on how to enter off-line mode or about operation.

Cf. Maintenance/Troubleshooting "2.2 Offline Mode"

■ Communication Settings

To display the setting screen, touch [Device/PLC Settings] from [Peripheral Settings] in off-line mode. Touch the External Device you want to set from the displayed list.

Comm.	Device	Option		
Q/QnA Serial Communication		[COM1]	Page 1/1	
SIO Type	RS232C			
Speed	19200			
Data Length	8			
Parity	<input type="radio"/> NONE <input type="radio"/> EVEN <input checked="" type="radio"/> ODD			
Stop Bit	<input checked="" type="radio"/> 1 <input type="radio"/> 2			
Flow Control	ER(DTR/CTS)			
Timeout(s)	3			
Retry	2			
Wait To Send(ms)	0			
Exit		Back		2005/09/02 12:38:18

Setup Items	Setup Description
SIO Type	Select the SIO type to communicate with the External Device. IMPORTANT To make the communication settings correctly, confirm the serial interface specifications of Display unit for [SIO Type]. We cannot guarantee the operation if a communication type that the serial interface does not support is specified. For details concerning the serial interface specifications, refer to the manual for Display unit.
Speed	Select speed between the External Device and the Display.
Data Length	Select data length.
Parity	Select how to check parity.
Stop Bit	Select stop bit length.
Flow Control	Select the communication control method to prevent overflow of transmission and reception data.
Timeout	Use an integer from 1 to 127 to enter the time (sec) for which the Display waits for the response from the External Device. NOTE In case of communicating via network, please set larger value than the response monitoring time of the relay station for timeout settings.

Setup Items	Setup Description
Retry	In case of no response from the External Device, use an integer from 0 to 255 to enter how many times the Display retransmits the command.
Wait To Send	Use an integer from 0 to 255 to enter standby time (ms) for the Display from receiving packets to transmitting next commands.

■ Device Setting

To display the setting screen, touch [Device/PLC Settings] from [Peripheral Settings]. Touch the External Device you want to set from the displayed list, and touch [Device].

Comm.	Device	Option		
Q/QnA Serial Communication		[COM1]	Page 1/1	
Device/PLC Name [PLC1] ▼				
Station No.		0	▼	▲
Network No.		0	▼	▲
PC No.		255	▼	▲
Request destination module				
I/O No.		1023	▼	▲
Station No.		0	▼	▲
Exit		Back		2005/09/02 12:38:20

Setup Items	Setup Description
Device/PLC Name	Select the External Device for device setting. Device name is a title of External Device set with GP-Pro EX.(Initial value [PLC1])
Station No.	Use an integer from 0 to 31 to enter the station number of the External Device directly connected to the Display.
Network No.	Set when you communicate via network. Use an integer from 0 to 239 to enter network No. of the External Device to communicate. If you do not communicate via network, enter 0.
PC No.	Set when you communicate via network. Use an integer from 0 to 64 to enter PC No. of the External Device to communicate. If you do not communicate via network, enter 255.
Request destination module I/O No.	Set when you communicate via network. Use an integer from 0 to 511 to enter I/O No. of the External Device to communicate. If you do not communicate via network, enter 1023.
Request destination module Station No.	Set when you communicate via network. Use an integer from 0 to 31 to enter station No. of the External Device to communicate. If you do not communicate via network, enter 0.

IMPORTANT

- Do not set the duplicate device settings in multiple devices. Illegal address may be read.

■ Option

To display the setting screen, touch [Device/PLC Settings] from [Peripheral Settings]. Touch the External Device you want to set from the displayed list, and touch [Option].

Comm.	Device	Option		
Q/QnA Serial Communication		[COM1]	Page 1/1	
RI / VCC <input checked="" type="radio"/> RI <input type="radio"/> VCC In the case of RS232C, you can select the 9th pin to RI(Input) or VCC(5V Power Supply). If you use the Digital's RS232C Isolation Unit, please select it to VCC.				
		Exit	Back	2005/09/02 12:38:22

Setup Items	Setup Description
RI/VCC	You can switch RI/VCC of the 9th pin when you select RS232C for SIO type. It is necessary to change RI/5V by changeover switch of IPC when connect with IPC. Please refer to the manual of the IPC for more detail.

5 Cable Diagram

The cable diagram shown below may be different from the cable diagram recommended by Mitsubishi Electric Corp. Please be assured there is no operational problem in applying the cable diagram shown in this manual.

- The FG pin of the External Device body must be D-class grounded. Please refer to the manual of the External Device for more details.
- SG and FG are connected inside the Display. When connecting SG to the External Device, design the system not to form short-circuit loop.
- Connect the isolation unit, when communication is not stabilized under the influence of a noise etc..

Cable Diagram 1

Display (Connection Port)	Cable		Notes
GP (COM1) IPC ^{*1}	A	Mitsubishi Q link cable by Pro-face CA3-CBLLNKMQ-01	The cable length must be 15m or less.
	B	Your own cable	

*1 Only the COM port which can communicate by RS-232C can be used.

☞ ■ COM Port of IPC (page 5)

A) When using Mitsubishi Q link cable (CA3-CBLLNKMQ-01) by Pro-face

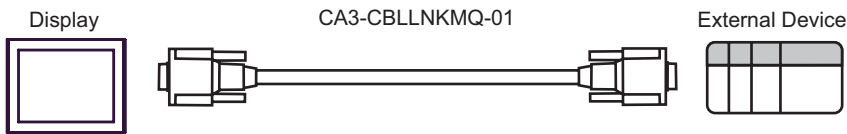

B) When using your own cable

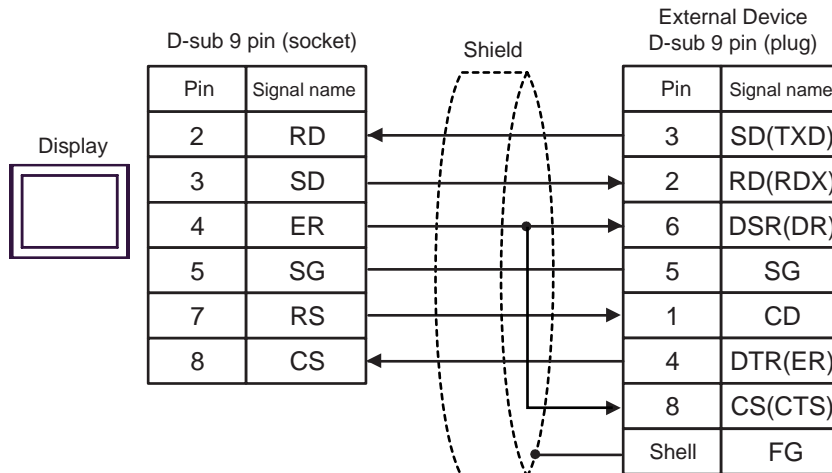

Cable Diagram 2

Display (Connection Port)	Cable		Notes
GP* ¹ (COM1) AGP-3302B (COM2) IPC* ²	A	COM port conversion adapter by Pro-face CA3-ADPCOM-01 + Connector terminal block conversion adapter by Pro-face CA3-ADPTRM-01 + Your own cable	The cable length must be 500m or less.
	B	Your own cable	
GP* ³ (COM2)	C	Online adapter by Pro-face CA4-ADPONL-01 + Connector terminal block conversion adapter by Pro-face CA3-ADPTRM-01 + Your own cable	
	D	Online adapter by Pro-face CA4-ADPONL-01 + Your own cable	

*1 All GP models except AGP-3302B

*2 Only the COM port which can communicate by RS-422/485 (4 wire) can be used.

 ■ COM Port of IPC (page 5)

*3 All GP models except GP-3200 series and AGP-3302B

A) When using the COM port conversion adapter (CA3-ADPCOM-01), the connector terminal block conversion adapter (CA3-ADPTRM-01) by Pro-face and your own cable

- 1:1 Connection

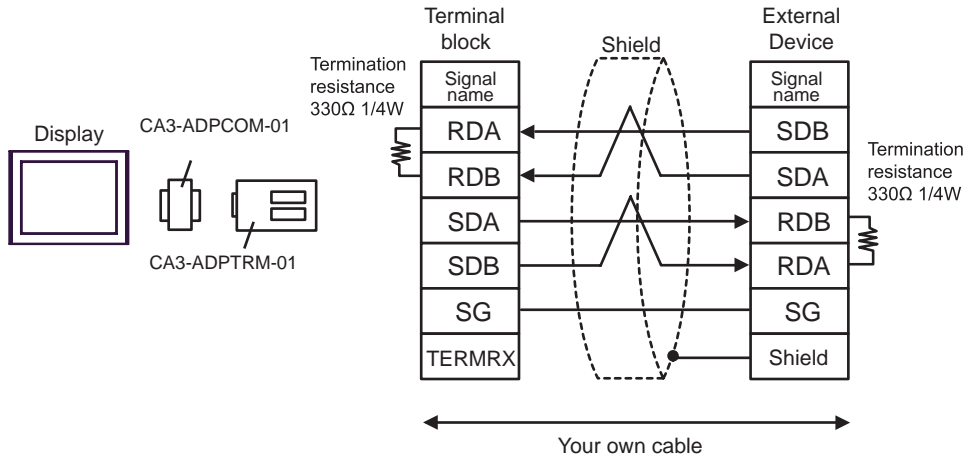

- 1:n Connection

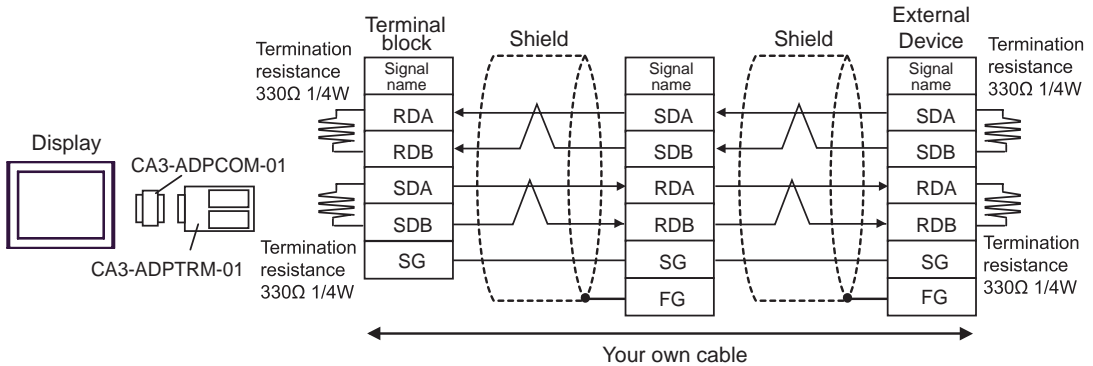

B) When using your own cable

- 1:1 Connection

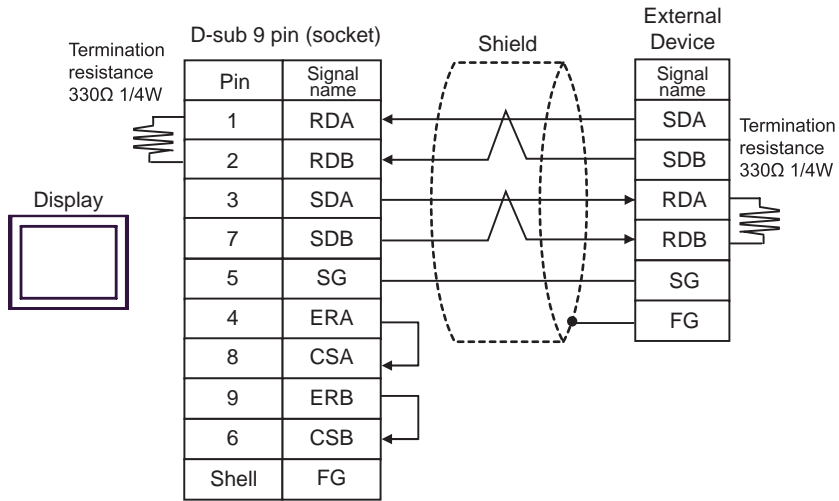

- 1:n Connection

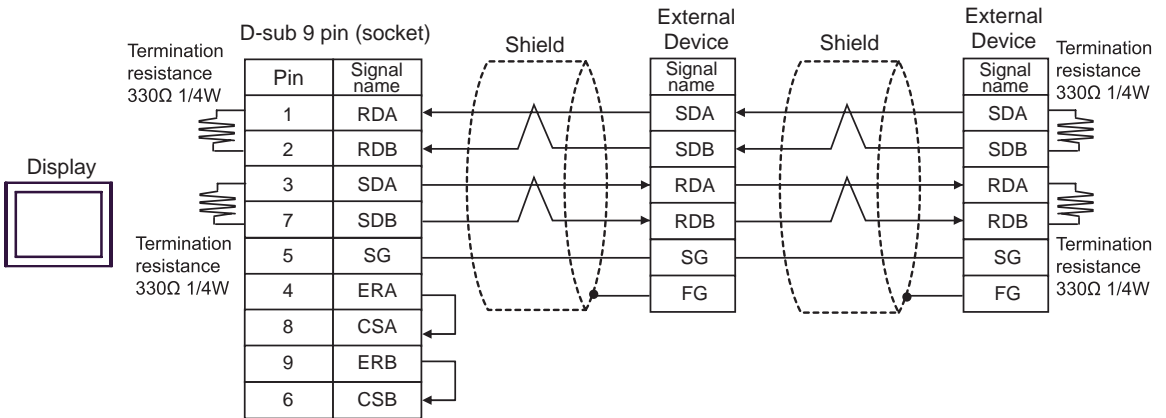

C) When using the online adapter (CA4-ADPONL-01), the connector terminal block conversion adapter (CA3-ADPTRM-01) by Pro-face and your own cable

- 1:1 Connection

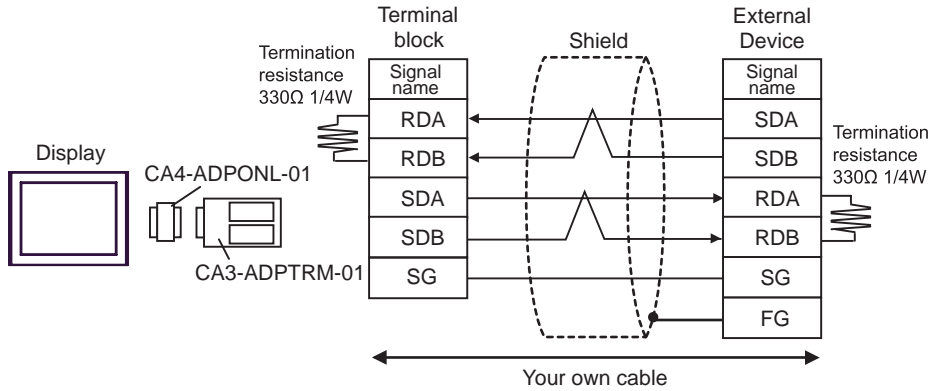

- 1:n Connection

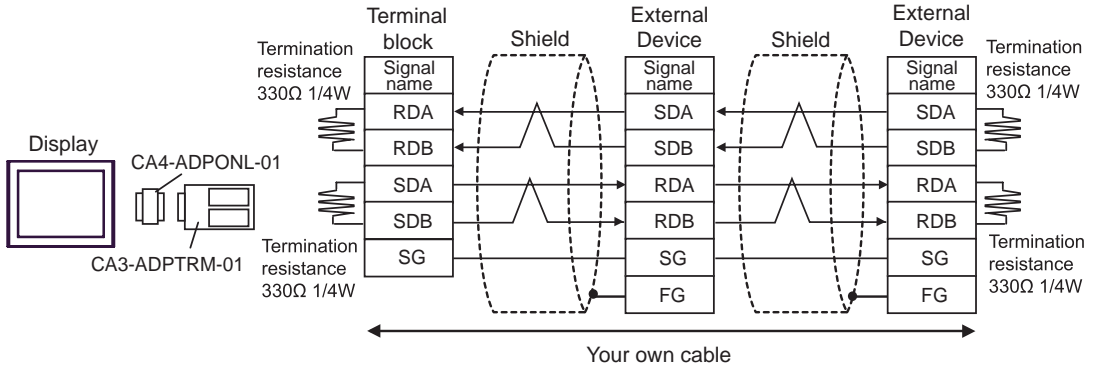

D) When using the online adapter (CA4-ADPONL-01) by Pro-face and your own cable

- 1:1 Connection

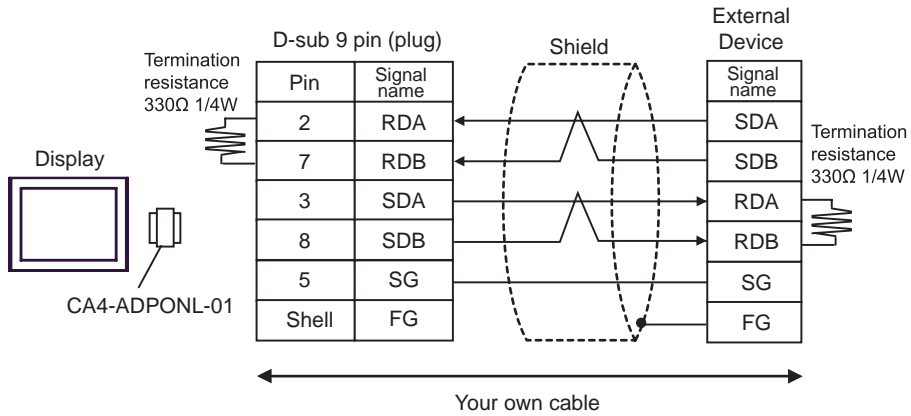

- 1:n Connection

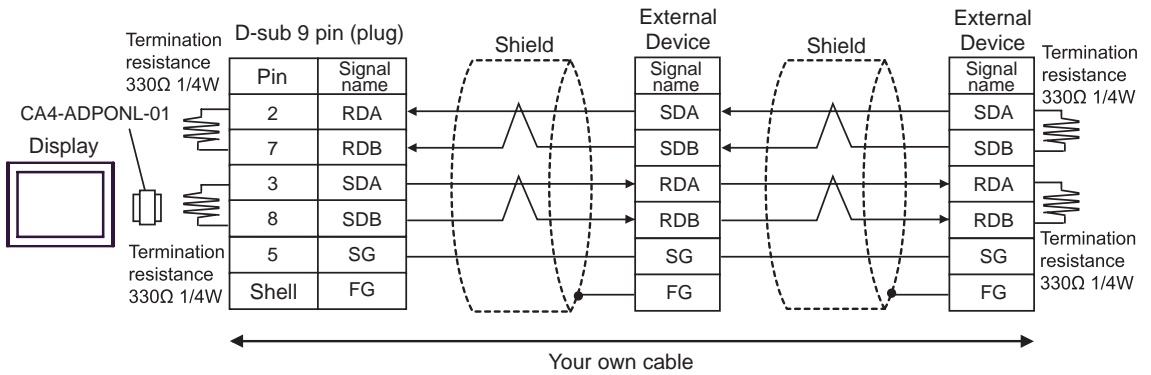

Cable Diagram 3

Display (Connection Port)	Cable	Notes
GP (COM1) IPC*1	Mitsubishi Q connection cable by Pro-face CA3-CBLQ-01 (5m) or RS-232C cable by Mitsubishi Electric Corp. QC30R2 (3m) or RS-232C cable for QCPU connection by Diatrend Corp. DQCABR2V-H	Available to order the length of DQXCABR2V-H by Diatrend Corp. up to 15m.

*1 Only the COM port which can communicate by RS-232C can be used.

 ■ COM Port of IPC (page 5)

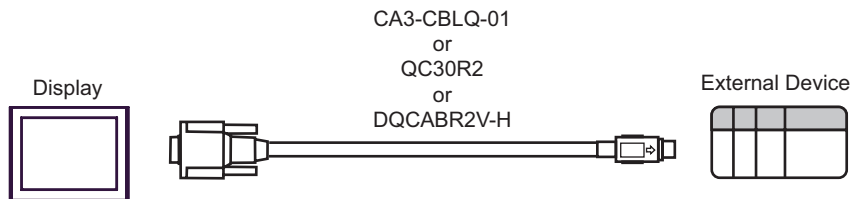

Cable Diagram 4

Display (Connection Port)	Cable		Notes
GP (COM1) IPC*1	A	RS-232C cable by Pro-face CA3-CBL232/5M-01 (5m)	
	B	Your own cable	The cable length must be 15m or less.

*1 Only the COM port which can communicate by RS-232C can be used.

☞ ■ COM Port of IPC (page 5)

A) When using the RS232C cable (CA3-CBL232/5M-01) by Pro-face

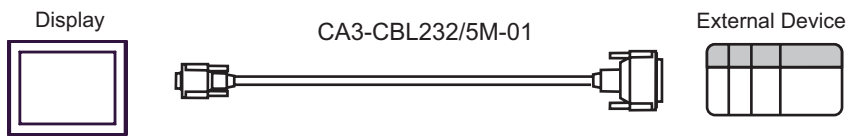

B) When using your own cable

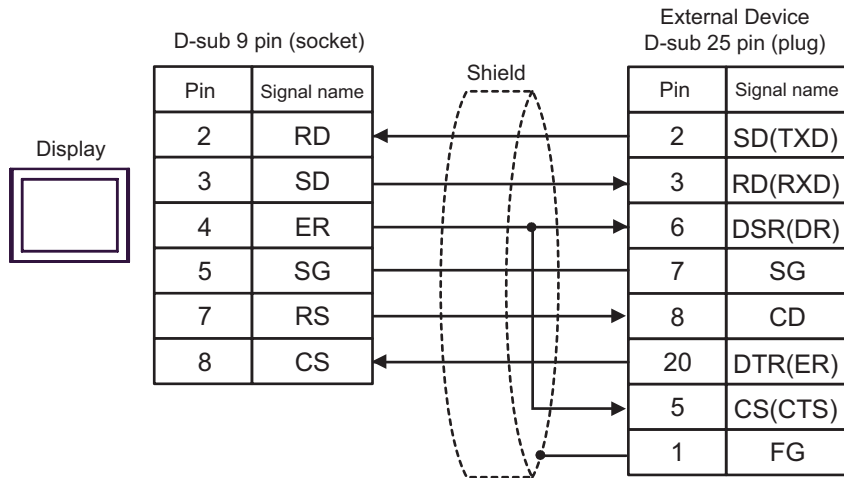

Cable Diagram 5

Display (Connection Port)		Cable	Notes
GP* ¹ (COM1) AGP-3302B (COM2) IPC* ²	A	COM port conversion adapter by Pro-face CA3-ADPCOM-01 + Connector terminal block conversion adapter by Pro-face CA3-ADPTRM-01 + Your own cable	The cable length must be 500m or less.
	B	Your own cable	
GP* ³ (COM2)	C	Online adapter by Pro-face CA4-ADPONL-01 + Connector terminal block conversion adapter by Pro-face CA3-ADPTRM-01 + Your own cable	
	D	Online adapter by Pro-face CA4-ADPONL-01 + Your own cable	

*1 All GP models except AGP-3302B

*2 Only the COM port which can communicate by RS-422/485 (4 wire) can be used.

 ■ COM Port of IPC (page 5)

*3 All GP models except GP-3200 series and AGP-3302B

A) When using the COM port conversion adapter (CA3-ADPCOM-01), the connector terminal block conversion adapter (CA3-ADPTRM-01) by Pro-face and your own cable

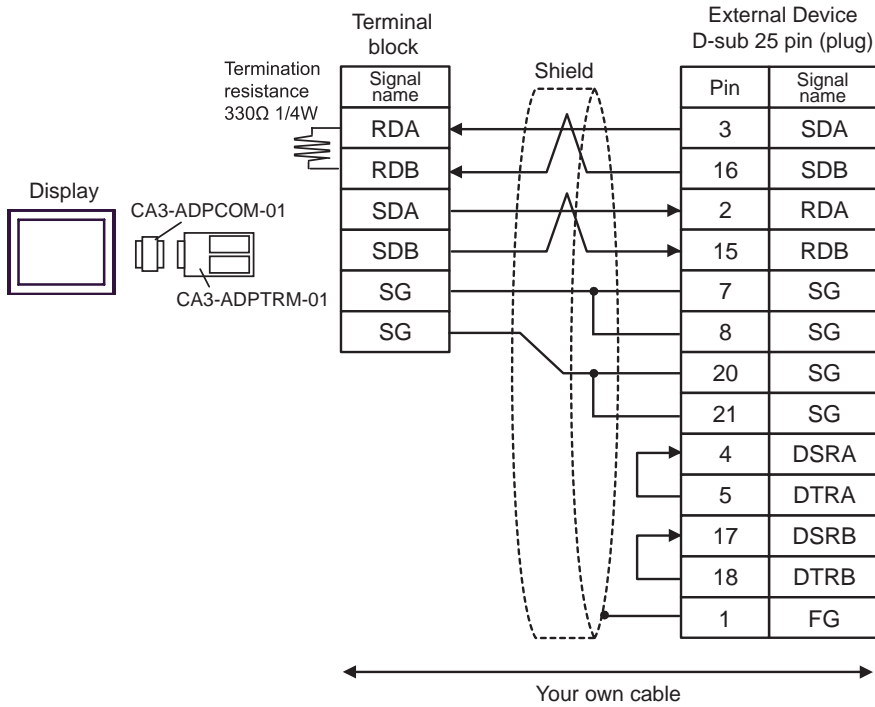

NOTE • As the External Device has the termination resistance built-in, you do not need to connect the termination resistance.

B) When using your own cable

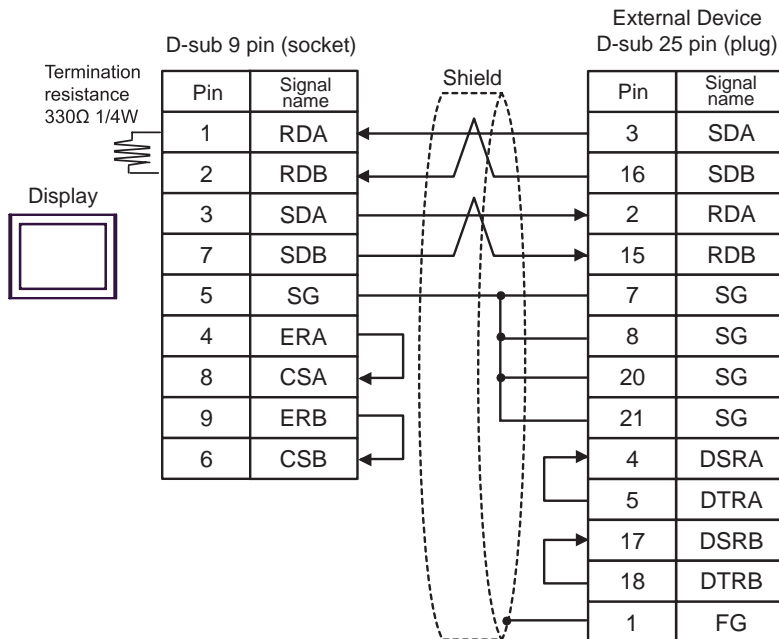

NOTE • As the External Device has the termination resistance built-in, you do not need to connect the termination resistance.

C) When using the online adapter (CA4-ADPONL-01), the connector terminal block conversion adapter (CA3-ADPTRM-01) by Pro-face and your own cable

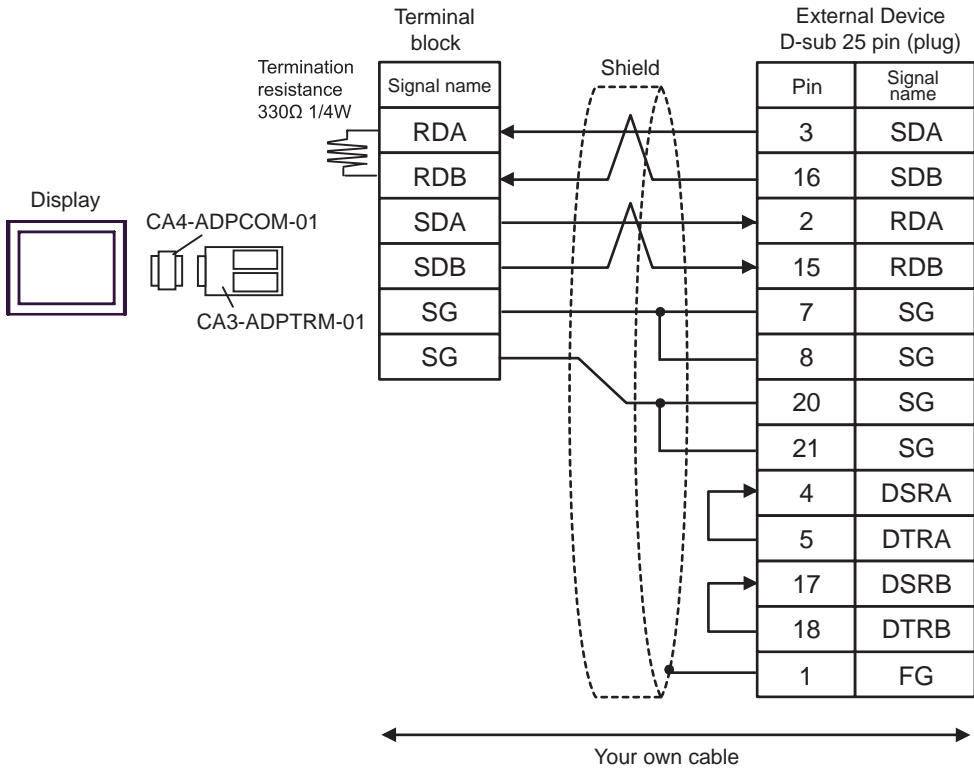

NOTE • As the External Device has the termination resistance built-in, you do not need to connect the termination resistance.

D) When using the online adapter (CA4-ADPONL-01) by Pro-face and your own cable

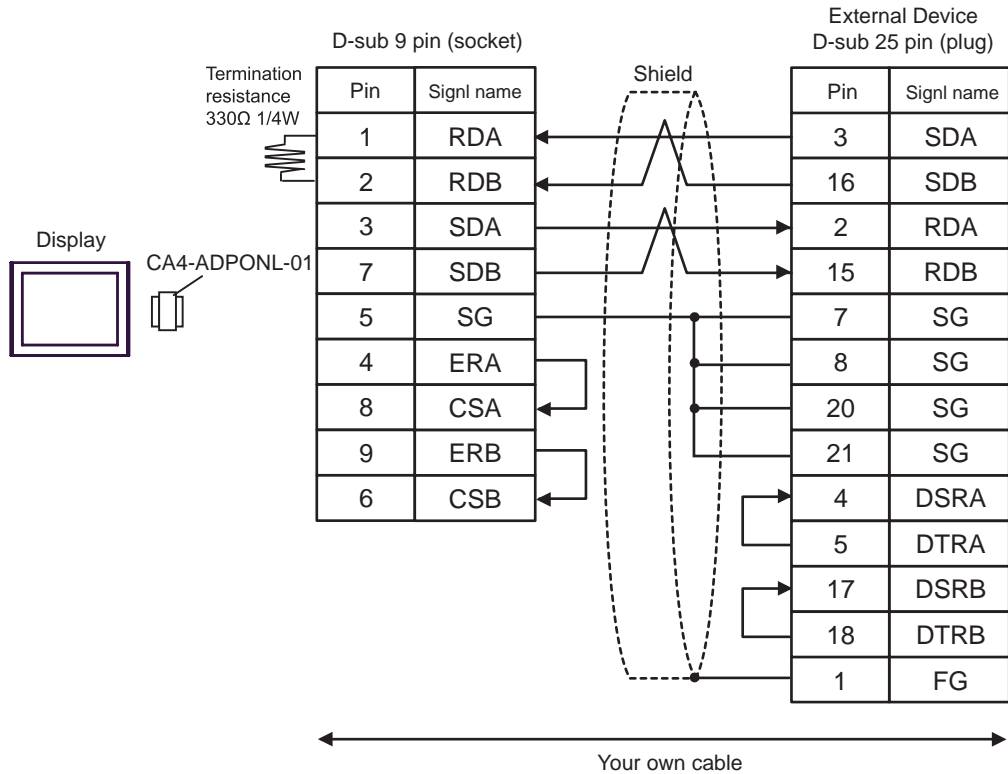
**NOTE**

- As the External Device has the termination resistance built-in, you do not need to connect the termination resistance.

6 Range of Supported Device Address

Range of supported device address is shown in the table below. Please note that the actually supported range of the devices varies depending on the External Device to be used. Please check the actual range in the manual of your External Device.

 This address can be specified as system data area.

Device	Bit Address	Word Address	32bits	Notes
Input Relay	X0000-X1FFF	X0000-X1FF0	L/H	
Output Relay	Y0000-Y1FFF	Y0000-Y1FF0		
Internal Relay	M00000-M32767	M00000-M32752		
Special Relay	SM0000-SM2047	SM0000-SM2032		
Latch Relay	L00000-L32767	L00000-L32752		
Annunciator	F00000-F32767	F00000-F32752		
Edge Relay	V00000-V32767	V00000-V32752		
Step Relay	S0000-S8191	S0000-S8176		
Link Relay	B0000-B7FFF	B0000-B7FF0		
Special Link Relay	SB000-SB7FF	SB000-SB7F0		
Timer (Contact)	TS00000-TS23087	-		
Timer (Coil)	TC00000-TC23087	-		
Retentive Timer (Contact)	SS00000-SS23087	-		
Retentive Timer (Coil)	SC00000-SC23087	-		
Counter (Contact)	CS00000-CS23087	-		
Counter (Coil)	CC00000-CC23087	-		
Timer (Current Value)	-	TN00000-TN23087		
Retentive Timer (Current Value)	-	SN00000-SN23087		
Counter (Current Value)	-	CN00000-CN23087		
Data Register	-	 D00000-D25983		
Special Register	-	SD0000-SD2047		
Link Register	-	W0000-W657F		
Special Link Register	-	SW000-SW77F		
File Register (Normal)	-	R00000-R32767	*1	
File Register (Block switching is not necessary)	-	ZR0000000-ZR1042431	*1	

Device	Bit Address	Word Address	32bits	Notes
File Register (0R - 31R) *2	-	0R0000-0R32767		 *1
	-	1R0000-1R32767		
	-	2R0000-2R32767		
	:	:		
	-	30R0000-30R32767		
	-	31R0000-31R26623		

*1 You need the memory card when using the file register.

*2 Set the block No. on the head of device name. This is the device name for conversion with GP-Pro/PB III for Windows. When you newly specify the device, we recommend that you should use the file register (Block switching is not necessary).

NOTE

- Please refer to the GP-Pro EX Reference Manual for system data area.
Cf. GP-Pro EX Reference Manual "Appendix 1.4 LS Area (only for direct access method)"
- Please refer to the precautions on manual notation for icons in the table.
 "Manual Symbols and Terminology"

7 Device Code and Address Code

Use device code and address code when you select "Device Type & Address" for the address type in data displays.

Device	Device Name	Device Code (HEX)	Address Code
Input Relay	X	0080	Value of word address divided by 0x10
Output Relay	Y	0081	Value of word address divided by 0x10
Internal Relay	M	0082	Value of word address divided by 16
Special Relay	SM	0083	Value of word address divided by 16
Latch Relay	L	0084	Value of word address divided by 16
Annunciator	F	0085	Value of word address divided by 16
Edge Relay	V	0086	Value of word address divided by 16
Step Relay	S	0087	Value of word address divided by 16
Link Relay	B	0088	Value of word address divided by 0x10
Special Link Relay	SB	0089	Value of word address divided by 0x10
Timer (Current Value)	TN	0060	Word Address
Retentive Timer (Current Value)	SN	0062	Word Address
Counter (Current Value)	CN	0061	Word Address
Data Register	D	0000	Word Address
Special Register	SD	0001	Word Address
Link Register	W	0002	Word Address
Special Link Register	SW	0003	Word Address
File Register (Normal)	R	000F	Word Address
File Register (Block switching is not necessary)	ZR	000E	Word Address
File Register (0R - 31R)	0R	0010	Word Address
	1R	0011	Word Address
	2R	0012	Word Address
	:	:	:
	30R	002E	Word Address
	31R	002F	Word Address

8 Error Messages

Error messages are displayed on the Display screen as follows: "No.: Device Name: Error Message (Error Occurrence Area)". Each description is shown below.

Item	Description
No.	Error No.
Device Name	Name of the External Device where error occurs. Device name is a title of the External Device set with GP-Pro EX. (Initial value [PLC1])
Error Message	Displays messages related to the error which occurs.
Error Occurrence Area	<p>Displays IP address or device address of the External Device where error occurs, or error codes received from the External Device.</p> <p>NOTE</p> <ul style="list-style-type: none"> • IP address is displayed such as "IP address(Decimal): MAC address(Hex)". • Device address is displayed such as "Address: Device address". • Received error codes are displayed such as "Decimal[Hex]".

Display Examples of Error Messages

"RHAA035: PLC1: Error has been responded for device write command (Error Code: 2 [02])"

-
- NOTE**
- Please refer to the manual of the External Device for more detail of received error codes.
 - Please refer to "When an error message is displayed (Error code list)" of "Maintenance/Troubleshooting" for a common error message to the driver.
-

