



# Series 90-30/70 SNP-X Driver

1	System Configuration.....	3
2	Selection of External Device .....	8
3	Example of Communication Setting.....	9
4	Setup Items.....	19
5	Cable Diagram .....	24
6	Supported Device.....	37
7	Device Code and Address Code.....	38
8	Error Messages.....	39

## Introduction

This manual describes how to connect the Display and the External Device (target PLC).

In this manual, the connection procedure will be described by following the below sections:

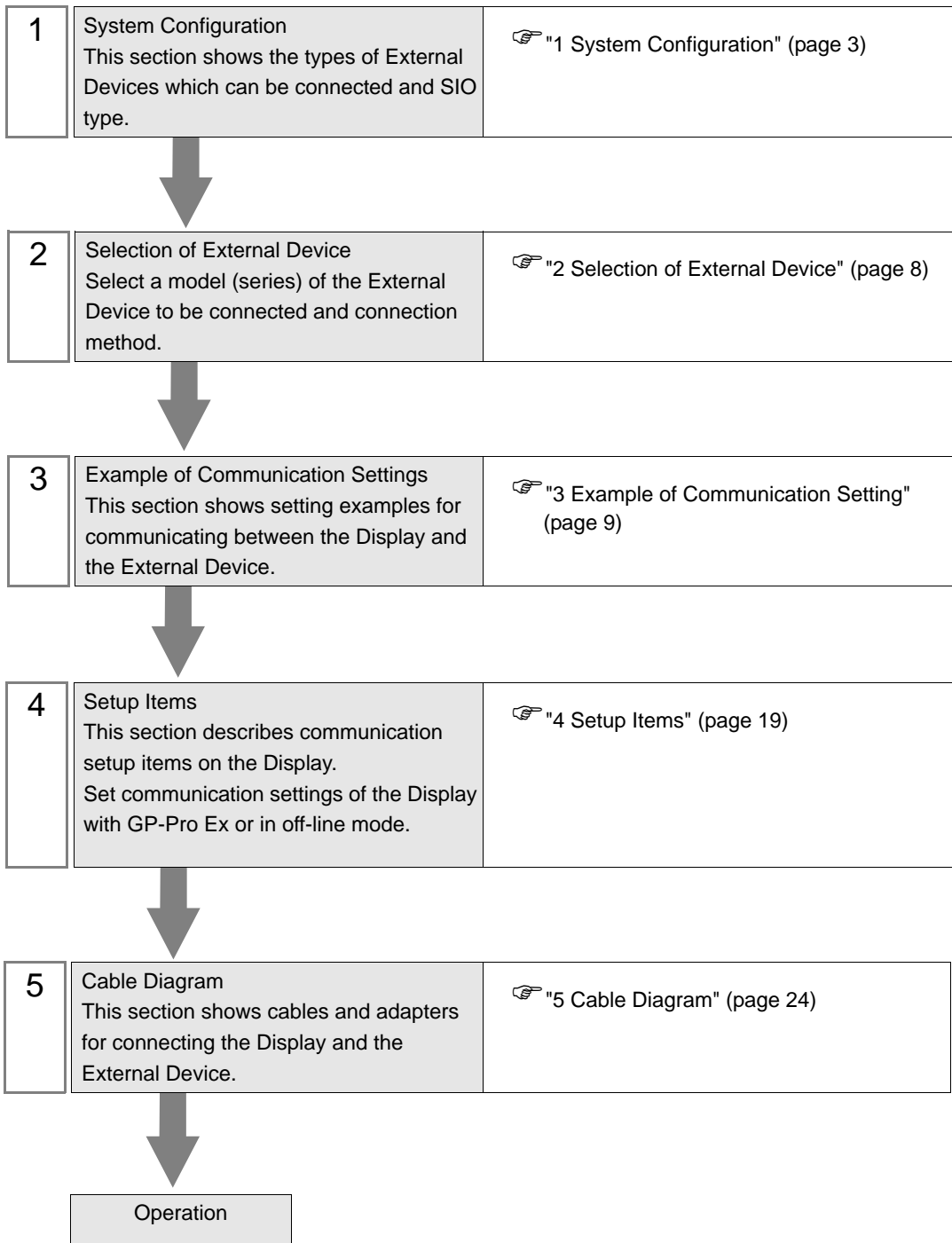

# 1 System Configuration

The system configuration in the case when the External Device of GE Fanuc Automation and the Display are connected is shown.

Series	CPU	Link I/F	SIO Type	Setting Example	Cable Diagram
Series 90-30	IC693CPU311 IC693CPU313 IC693CPU321 IC693CPU323 IC693CPU331 IC693CPU340 IC693CPU341 IC693CPU350 IC693CPU360 IC693CPU364	Connector on power supply (Built-in Serial Port)	RS485 (4 wire)	Setting Example 1 (page 9)	Cable Diagram 1 (page 24)
		IC693CMM311*1	RS232	Setting Example 2 (page 11)	Cable Diagram 2 (page 29)
			RS485 (4 wire)	Setting Example 3 (page 13)	Cable Diagram 3 (page 30)
	IC693CPU351 IC693CPU352 IC693CPU363	Connector on power supply (Built-in Serial Port)	RS485 (4 wire)	Setting Example 1 (page 9)	Cable Diagram 1 (page 24)
		Port1 on CPU Unit	RS232C	Setting Example 4 (page 15)	Cable Diagram 4 (page 35)
		Port2 on CPU Unit	RS485 (4 wire)	Setting Example 5 (page 17)	Cable Diagram 1 (page 24)
		IC693CMM311*1	RS232C	Setting Example 2 (page 11)	Cable Diagram 2 (page 29)
			RS485 (4 wire)	Setting Example 3 (page 13)	Cable Diagram 3 (page 30)
		IC693CPU374	Port on Power supply	RS485 (4 wire)	Setting Example 1 (page 9)
	IC693CMM311*1		RS232C	Setting Example 2 (page 11)	Cable Diagram 2 (page 29)
			RS485 (4 wire)	Setting Example 3 (page 13)	Cable Diagram 3 (page 30)

Series	CPU	Link I/F	SIO Type	Setting Example	Cable Diagram
Series 90-70	IC697CPU731	IC697CMM711 <sup>*2</sup>	RS232C	Setting Example 2 (page 11)	Cable Diagram 2 (page 29)
	IC697CPU732				
	IC697CPU771				
	IC697CPU772				
	IC697CPU781				
	IC697CPU782				
	IC697CPU788				
	IC697CPU789				
	IC697CPM790				
	IC697CPM914				
	IC697CPM915				
	IC697CPM924				
	IC697CPM925				
	IC697CPX772				
	IC697CPX782				
	IC697CPX928				
IC697CPX935					
VersaMax Micro	IC200UAL004/005/006	Port1 on CPU Unit	RS232C	Setting Example 4 (page 15)	Cable Diagram 5 (page 36)
	IC200UDD110/120/212	Port2 on CPU Unit	RS485 (4 wire)	Setting Example 5 (page 17)	Cable Diagram 1 (page 24)
	IC200UDR005/006/010				
	IC200UAA007				
	IC200UAR028				

\*1 Select SNP-X protocol using the programming console, and the PLC's WYE cable is necessary. Both Port1 and Port2 can be used as RS-232C connection, and only Port2 can be used as RS-485 connection. When Port2 is used, programming console is needed to select RS-232C or RS-485 connection.

\*2 Select SNP-X protocol using the programming console, and change the interface of Port1/Port2 to RS-232C or RS-485.

## ■ Connection Configuration

- 1:1 Connection

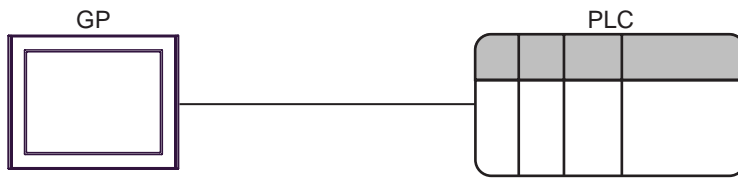

- 1:n Connection

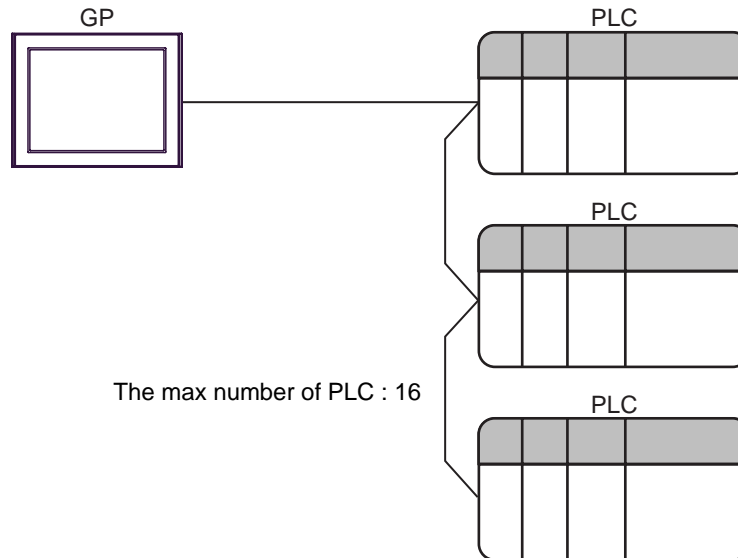

## ■ COM Port of IPC

When connecting IPC with External Device, the COM port which can be used changes with series and SIO type. Please refer to the manual of IPC for details.

### Usable port

Series	Usable port		
	RS-232C	RS-422/485(4 wire)	RS-422/485(2 wire)
PS-2000B	COM1 <sup>*1</sup> , COM2, COM3 <sup>*1</sup> , COM4	-	-
PS-3650A, PS-3651A	COM1 <sup>*1</sup>	-	-
PS-3700A (Pentium®4-M) PS-3710A	COM1 <sup>*1</sup> , COM2 <sup>*1</sup> , COM3 <sup>*2</sup> , COM4	COM3 <sup>*2</sup>	COM3 <sup>*2</sup>
PS-3711A	COM1 <sup>*1</sup> , COM2 <sup>*2</sup>	COM2 <sup>*2</sup>	COM2 <sup>*2</sup>

\*1 The RI/5V can be switched. Please switch with the change switch of IPC.

\*2 It is necessary to set up the SIO type with the Dip switch. Please set up as follows according to SIO type to be used.

### Dip switch setting: RS-232C

Dip switch	Setting	Description
1	OFF	Reserve (always OFF)
2	OFF	SIO type: RS-232C
3	OFF	
4	OFF	Output mode of SD (TXD) data: Always output
5	OFF	Terminal resistance (220Ω) insertion to SD (TXD): None
6	OFF	Terminal resistance (220Ω) insertion to RD (RXD): None
7	OFF	Short-circuit of SDA (TXA) and RDA (RXA): Does not Exist
8	OFF	Short-circuit of SDB (TXB) and RDB (RXB): Does not Exist
9	OFF	RS (RTS) Auto control mode: Disable
10	OFF	

## Dip switch setting: RS-422/485 (4 wire)

Dip switch	Setting	Description
1	OFF	Reserve (always OFF)
2	ON	SIO type: RS-422/485
3	ON	
4	OFF	Output mode of SD (TXD) data: Always output
5	OFF	Terminal resistance (220Ω) insertion to SD (TXD): None
6	OFF	Terminal resistance (220Ω) insertion to RD (RXD): None
7	OFF	Short-circuit of SDA (TXA) and RDA (RXA): Does not Exist
8	OFF	Short-circuit of SDB (TXB) and RDB (RXB): Does not Exist
9	OFF	RS (RTS) Auto control mode: Disable
10	OFF	

## Dip switch setting: RS-422/485 (2 wire)

Dip switch	Setting	Description
1	OFF	Reserve (always OFF)
2	ON	SIO type: RS-422/485
3	ON	
4	OFF	Output mode of SD (TXD) data: Always output
5	OFF	Terminal resistance (220Ω) insertion to SD (TXD): None
6	OFF	Terminal resistance (220Ω) insertion to RD (RXD): None
7	ON	Short-circuit of SDA (TXA) and RDA (RXA): Exist
8	ON	Short-circuit of SDB (TXB) and RDB (RXB): Exist
9	ON	RS (RTS) Auto control mode: Enable
10	ON	

## 2 Selection of External Device

Select the External Device to be connected to the Display.

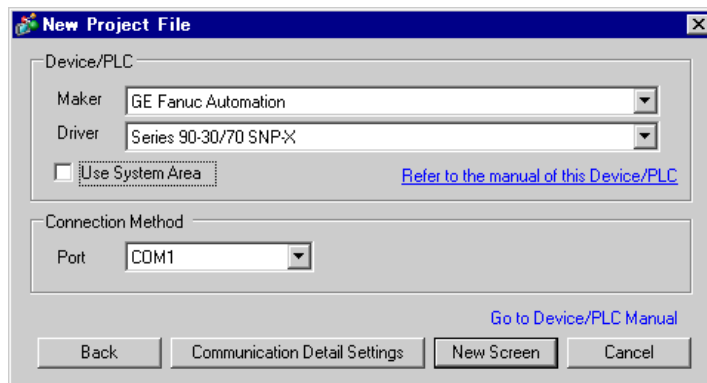

Setup Items	Setup Description
Maker	Select the maker of the External Device to be connected. Select "GE Fanuc Automation".
Driver	Select a model (series) of the External Device to be connected and connection method. Select "Series 90-30/70 SNP-X". Check the External Device which can be connected in "Series 90-30/70 SNP-X" in system configuration. ☞ "1 System Configuration" (page 3)
Use System Area	Check this option when you synchronize the system data area of Display and the device (memory) of External Device. When synchronized, you can use the ladder program of External Device to switch the display or display the window on the display. Cf. GP-Pro EX Reference Manual "Appendix 1.4 LS Area (only for direct access method)" This can be also set with GP-Pro EX or in off-line mode of Display. Cf. GP-Pro EX Reference Manual " 5.14.6 Setting Guide of [System Setting Window]■[Main Unit Settings] Settings Guide◆System Area Setting" Cf. Maintenance/Troubleshooting "2.14.1 Settings common to all Display models ◆System Area Settings"
Port	Select the Display port to be connected to the External Device.



### 3 Example of Communication Setting

Examples of communication settings of the Display and the External Device, recommended by Pro-face, are shown.

#### 3.1 Setting Example 1

##### ■ Settings of GP-Pro EX

##### ◆ Communication Settings

To display the setting screen, select [Device/PLC Settings] from [System setting window] in workspace.

##### ◆ Device Setting

To display the setting screen, click  ([Setting]) of External Device you want to set from [Device-Specific Settings] of [Device/PLC Settings].

When you connect multiple External Device, click  from [Device-Specific Settings] of [Device/PLC Settings] to add another External Device.

## ■ Settings of External Device

Use the ladder software for communication settings. (Check the operation in CIMPLICITY Machine Edition V4.50)

- 1 Select "Add Target" -> "GE Fanuc PLC" among "Project" of tool bar and select the series to be connected.  
The selected series is added as "Target" in the project.
- 2 Allocate the power supply module and the CPU module in "Hardware Configuration" -> "Main Rack" of added Target.

---

**NOTE** • The Rack number and Slot number to allocate by environment using are different.  
Check the environment, and allocate the Rack number and Slot number.

---

- 3 Double-click the CPU module, display the setting window.
- 4 Click the [Settings] tab and set the communication settings.
- 5 Forward the communication settings to the external device and spend a power supply of the external device again.

### ◆ Setup Items

Setup Items	Setup Description
Data Rate [bps]	19200
Parity	Odd
Stop Bits	1
SNP ID	1

### ◆ Notes

- Please refer to the manual of the ladder software for more detail on other setting description.

## 3.2 Setting Example 2

### ■ Settings of GP-Pro EX

#### ◆ Communication Settings

To display the setting screen, select [Device/PLC Settings] from [System setting window] in workspace.

Device/PLC 1

Summary [Change Device/PLC](#)

Maker  Driver  Port

Text Data Mode  [Change](#)

Communication Settings

SID Type  RS232C  RS422/485(2wire)  RS422/485(4wire)

Speed

Data Length  7  8

Parity  NONE  EVEN  ODD

Stop Bit  1  2

Flow Control  NONE  ER(DTR/CTS)  XON/XOFF

Timeout  (sec)

Retry

Wait To Send  (ms)

RI / VCC  RI  VCC

In the case of RS232C, you can select the 9th pin to RI (Input) or VCC (5V Power Supply). If you use the Digital's RS232C Isolation Unit, please select it to VCC.

Device-Specific Settings

Allowable No. of Device/PLCs 16 Unit(s)

No.	Device Name	Settings
<input type="button" value="Remove"/> 1	<input type="text" value="PLC1"/>	<input type="text" value="SNP ID=1"/>

#### ◆ Device Setting

To display the setting screen, click  ([Setting]) of External Device you want to set from [Device-Specific Settings] of [Device/PLC Settings].

When you connect multiple External Device, click  from [Device-Specific Settings] of [Device/PLC Settings] to add another External Device.

Individual Device Setti...

PLC1

SNP ID

## ■ Settings of External Device

Use the ladder software for communication settings. (Check the operation in CIMPLICITY Machine Edition V4.50)

1 Select "Add Target" -> "GE Fanuc PLC" among "Project" of tool bar and select the series to be connected.

The selected series is added as "Target" in the project.

2 Allocate the power supply module, the CPU module and the link I/F module in "Hardware Configuration" -> "Main Rack" of added Target.

---

**NOTE** • The Rack number and Slot number to allocate by environment using are different.  
Check the environment, and allocate the Rack number and Slot number.

---

3 Double-click the CPU module and the link I/F module, display the setting window.

4 Set the communication settings.

5 Forward the communication settings to the external device and spend a power supply of the external device again.

### ◆ Setup Items

- CPU module

[Settings] tab

Setup Items	Setup Description
SNP ID	1

- Link I/F module

[Settings] tab

Setup Items	Setup Description
Configuration Mode	SNP Only

[Port1] tab

Setup Items	Setup Description
SNP Enable	Yes
SNP Mode	Slave
Data Rate [bps]	19200
Parity	Odd
Stop Bits	1
Flow Contro	None

### ◆ Notes

Please refer to the manual of the ladder software for more detail on other setting description.

### 3.3 Setting Example 3

#### ■ Settings of GP-Pro EX

##### ◆ Communication Settings

To display the setting screen, select [Device/PLC Settings] from [System setting window] in workspace.

##### ◆ Device Setting

To display the setting screen, click  ([Setting]) of External Device you want to set from [Device-Specific Settings] of [Device/PLC Settings].

When you connect multiple External Device, click  from [Device-Specific Settings] of [Device/PLC Settings] to add another External Device.

## ■ Settings of External Device

Use the ladder software for communication settings. (Check the operation in CIMPLICITY Machine Edition V4.50)

1 Select "Add Target" -> "GE Fanuc PLC" among "Project" of tool bar and select the series to be connected.

The selected series is added as "Target" in the project.

2 Allocate the power supply module, the CPU module and the link I/F module in "Hardware Configuration" -> "Main Rack" of added Target.

---

**NOTE** • The Rack number and Slot number to allocate by environment using are different.  
Check the environment, and allocate the Rack number and Slot number.

---

3 Double-click the CPU module and the link I/F module, display the setting window.

4 Set the communication settings.

5 Forward the communication settings to the external device and spend a power supply of the external device again.

### ◆ Setup Items

- CPU module

[Settings] tab

Setup Items	Setup Description
SNP ID	1

- Link I/F module

[Settings] tab

Setup Items	Setup Description
Configuration Mode	SNP Only

[Port1] tab

Setup Items	Setup Description
SNP Enable	Yes
SNP Mode	Slave
Interface	RS485
Data Rate [bps]	19200
Parity	Odd
Stop Bits	1
Flow Contro	None

### ◆ Notes

Please refer to the manual of the ladder software for more detail on other setting description.

## 3.4 Setting Example 4

### ■ Settings of GP-Pro EX

#### ◆ Communication Settings

To display the setting screen, select [Device/PLC Settings] from [System setting window] in workspace.

#### ◆ Device Setting

To display the setting screen, click  ([Setting]) of External Device you want to set from [Device-Specific Settings] of [Device/PLC Settings].

When you connect multiple External Device, click  from [Device-Specific Settings] of [Device/PLC Settings] to add another External Device.

## ■ Settings of External Device

Use the ladder software for communication settings. (Check the operation in CIMPLICITY Machine Edition V4.50)

- 1 Select "Add Target" -> "GE Fanuc PLC" among "Project" of tool bar and select the series to be connected.  
The selected series is added as "Target" in the project.
  - 2 Allocate the power supply module and the CPU module in "Hardware Configuration" -> "Main Rack" of added Target.
- 
- NOTE** • The Rack number and Slot number to allocate by environment using are different.  
Check the environment, and allocate the Rack number and Slot number.
- 
- 3 Double-click the CPU module, display the setting window.
  - 4 Set the communication settings.
  - 5 Forward the communication settings to the external device and spend a power supply of the external device again.

### ◆ Setup Items

[Port1 (RS-232)] tab

Setup Items	Setup Description
Port Mode	SNP
Port Type	Slave
Data Rate [bps]	19200
Parity	Odd
Stop Bits	1
SNP ID	1

### ◆ Notes

Please refer to the manual of the ladder software for more detail on other setting description.



## 3.5 Setting Example 5

### ■ Settings of GP-Pro EX

#### ◆ Communication Settings

To display the setting screen, select [Device/PLC Settings] from [System setting window] in workspace.

Device/PLC 1

Summary [Change Device/PLC](#)

Maker  Driver  Port

Text Data Mode  [Change](#)

Communication Settings

SI0 Type  RS232C  RS422/485(2wire)  RS422/485(4wire)

Speed

Data Length  7  8

Parity  NONE  EVEN  ODD

Stop Bit  1  2

Flow Control  NONE  ER(DTR/CTS)  XON/XOFF

Timeout  (sec)

Retry

Wait To Send  (ms)

RI / VCC  RI  VCC

In the case of RS232C, you can select the 9th pin to RI (Input) or VCC (5V Power Supply). If you use the Digital's RS232C Isolation Unit, please select it to VCC.

Device-Specific Settings

Allowable No. of Device/PLCs: 16 Unit(s)

No.	Device Name	Settings
1	PLC1	SNP ID=1

#### ◆ Device Setting

To display the setting screen, click  ([Setting]) of External Device you want to set from [Device-Specific Settings] of [Device/PLC Settings].

When you connect multiple External Device, click  from [Device-Specific Settings] of [Device/PLC Settings] to add another External Device.

Individual Device Setti...

PLC1

SNP ID

## ■ Settings of External Device

Use the ladder software for communication settings. (Check the operation in CIMPLICITY Machine Edition V4.50)

- 1 Select "Add Target" -> "GE Fanuc PLC" among "Project" of tool bar and select the series to be connected.  
The selected series is added as "Target" in the project.
- 2 Allocate the power supply module and the CPU module in "Hardware Configuration" -> "Main Rack" of added Target.

---

**NOTE** • The Rack number and Slot number to allocate by environment using are different.  
Check the environment, and allocate the Rack number and Slot number.

---

- 3 Double-click the CPU module, display the setting window.
- 4 Set the communication settings.
- 5 Forward the communication settings to the external device and spend a power supply of the external device again.

### ◆ Setup Items

[Port1 (RS-232)] tab

Setup Items	Setup Description
Port Mode	SNP
Port Type	Slave
Data Rate [bps]	19200
Parity	Odd
Stop Bits	1
SNP ID	1

### ◆ Notes

Please refer to the manual of the ladder software for more detail on other setting description.

## 4 Setup Items

Set communication settings of the Display with GP-Pro EX or in off-line mode of the Display.

The setting of each parameter must be identical to that of External Device.

 "3 Example of Communication Setting" (page 9)

### 4.1 Setup Items in GP-Pro EX

#### ■ Communication Settings

To display the setting screen, select [Device/PLC Settings] from [System setting window] in workspace.

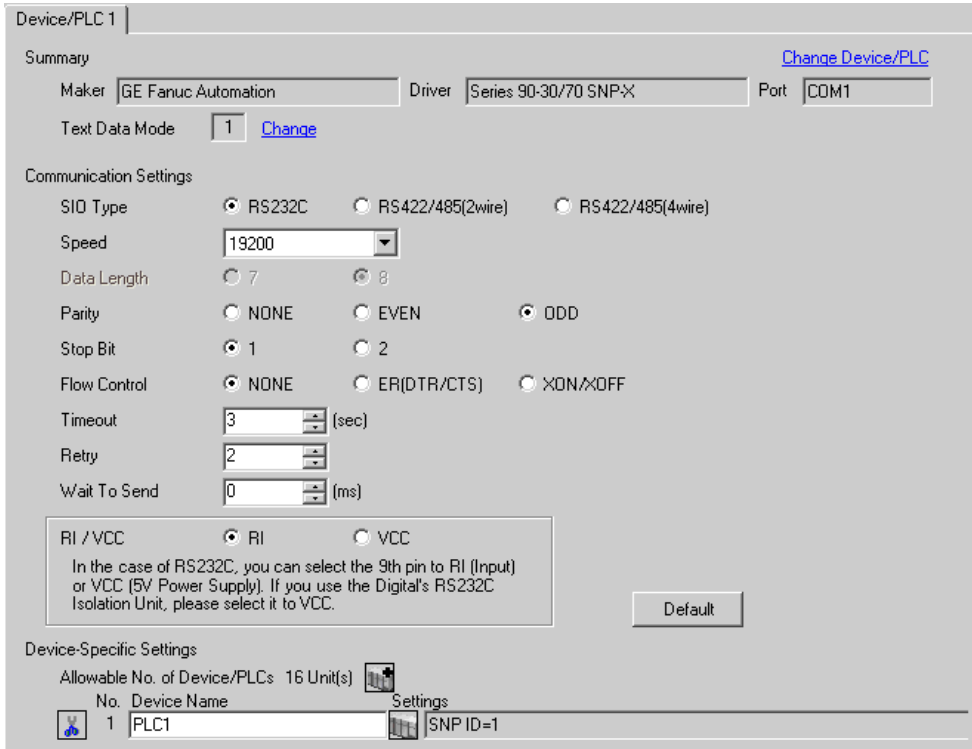

Device/PLC 1

Summary [Change Device/PLC](#)

Maker  Driver  Port

Text Data Mode  [Change](#)

Communication Settings

SIO Type  RS232C  RS422/485(2wire)  RS422/485(4wire)

Speed

Data Length  7  8

Parity  NONE  EVEN  ODD

Stop Bit  1  2

Flow Control  NONE  ER(DTR/CTS)  XON/XOFF

Timeout  (sec)

Retry

Wait To Send  (ms)

RI / VCC  RI  VCC

In the case of RS232C, you can select the 9th pin to RI (Input) or VCC (5V Power Supply). If you use the Digital's RS232C Isolation Unit, please select it to VCC.

Device-Specific Settings

Allowable No. of Device/PLCs 16 Unit(s) 

No. Device Name Settings

Setup Items	Setup Description
SIO Type	Select the SIO type to communicate with the External Device.
Speed	Select speed between the External Device and the Display.
Data Length	Display data length.
Parity	Select how to check parity.
Stop Bit	Select stop bit length.
Flow Control	Select the communication control method to prevent overflow of transmission and reception data.
Timeout	Use an integer from 1 to 127 to enter the time (s) for which the Display waits for the response from the External Device.
Retry	In case of no response from the External Device, use an integer from 0 to 255 to enter how many times the Display retransmits the command.

Setup Items	Setup Description
Wait To Send	Use an integer from 0 to 255 to enter standby time (ms) for the Display from receiving packets to transmitting next commands.
RI/VCC	You can switch RI/VCC of the 9th pin when you select RS232C for SIO type. It is necessary to change RI/5V by changeover switch of IPC when connect with IPC. Please refer to the manual of the IPC for more detail.

#### ◆ Device Setting

To display the setting screen, click  ([Setting]) of External Device you want to set from [Device-Specific Settings] of [Device/PLC Settings].

When you connect multiple External Device, click  from [Device-Specific Settings] of [Device/PLC Settings] to add another External Device.



Setup Items	Setup Description
SNP ID	Set the SNP ID of the External Device. SNP ID can contain up to 7 characters, the valid characters should be '0' - '9', 'A' - 'Z', 'a' - 'z', '_'. .

## 4.2 Setup Items in Off-Line Mode

**NOTE** • Please refer to Maintenance/Troubleshooting for more information on how to enter off-line mode or about operation.

Cf. Maintenance/Troubleshooting "2.2 Offline Mode"

### ◆ Communication Settings

To display the setting screen, touch [Device/PLC Settings] from [Peripheral Settings] in off-line mode. Touch the External Device you want to set from the displayed list.

Comm.	Device	Option		
Series 90-30/70 SNP-X		[COM1]	Page 1/1	
SIO Type	RS232C			
Speed	19200			
Data Length	8			
Parity	<input type="radio"/> NONE <input type="radio"/> EVEN <input checked="" type="radio"/> ODD			
Stop Bit	<input checked="" type="radio"/> 1 <input type="radio"/> 2			
Flow Control	NONE			
Timeout(s)	3			
Retry	2			
Wait To Send(ms)	0			
Exit		Back		2006/04/25 10:38:37

Setup Items	Setup Description
SIO Type	Select the SIO type to communicate with the External Device. <b>IMPORTANT</b> To make the communication settings correctly, confirm the serial interface specifications of Display unit for [SIO Type]. We cannot guarantee the operation if a communication type that the serial interface does not support is specified. For details concerning the serial interface specifications, refer to the manual for Display unit.
Speed	Select speed between the External Device and the Display.
Data Length	Display data length.
Parity	Select how to check parity.
Stop Bit	Select stop bit length.
Flow Control	Select the communication control method to prevent overflow of transmission and reception data.
Timeout	Use an integer from 1 to 127 to enter the time (s) for which the Display waits for the response from the External Device.

Setup Items	Setup Description
Retry	In case of no response from the External Device, use an integer from 0 to 255 to enter how many times the Display retransmits the command.
Wait To Send	Use an integer from 0 to 255 to enter standby time (ms) for the Display from receiving packets to transmitting next commands.

#### ◆ Device Setting

To display the setting screen, touch [Device/PLC Settings] from [Peripheral Settings]. Touch the External Device you want to set from the displayed list, and touch [Device]..

Comm.	Device	Option		
Series 90-30/70 SNP-X		[COM1]	Page 1/1	
Device/PLC Name		[PLC1]		
SNP ID		[ 1 ]		
SNP ID can contain up to 7 characters, the valid characters should be 0-9, A-Z, a-z, _(under bar).				
Exit		Back		2006/04/25 10:38:40

Setup Items	Setup Description
Device/PLC Name	Select the External Device for device setting. Device name is a title of External Device set with GP-Pro EX.(Initial value [PLC1])
SNP ID	Set the SNP ID of the External Device. SNP ID can contain up to 7 characters, the valid characters should be '0' - '9', 'A' - 'Z', 'a' - 'z', '_':

## ◆ Option

To display the setting screen, touch [Device/PLC Settings] from [Peripheral Settings]. Touch the External Device you want to set from the displayed list, and touch [Option].

Comm.	Device	Option		
Series 90-30/70 SNP-X			[COM1]	Page 1/1
RI / VCC <input checked="" type="radio"/> RI <input type="radio"/> VCC In the case of RS232C, you can select the 9th pin to RI(Input) or VCC(5V Power Supply). If you use the Digital's RS232C Isolation Unit, please select it to VCC.				
	Exit		Back	2006/04/25 10:38:43

Setup Items	Setup Description
RI/VCC	You can switch RI/VCC of the 9th pin when you select RS232C for SIO type. It is necessary to change RI/5V by changeover switch of IPC when connect with IPC. Please refer to the manual of the IPC for more detail.

## 5 Cable Diagram

The cable diagram shown below may be different from the cable diagram recommended by Schneider Electric Industries. Please be assured there is no operational problem in applying the cable diagram shown in this manual.

- The FG pin of the External Device body must be D-class grounded. Please refer to the manual of the External Device for more details.
- SG and FG are connected inside the Display. When connecting SG to the External Device, design the system not to form short-circuit loop.
- Connect the isolation unit, when communication is not stabilized under the influence of a noise etc..

Cable Diagram 1

Display (Connection Port)	Cable		Notes
GP* <sup>1</sup> (COM1) AGP-3302B (COM2) IPC* <sup>2</sup>	A	COM port conversion adapter by Pro-face CA3-ADPCOM-01 + Terminal block conversion adapter by Pro-face CA3-ADPTRM-01 + Your own cable	The cable length must be 15m or less.
	B	Your own cable	
GP* <sup>3</sup> (COM2)	C	Online adapter by Pro-face CA4-ADPONL-01 + Terminal block conversion adapter by Pro-face CA3-ADPTRM-01 + Your own cable	
	D	Online adapter by Pro-face CA4-ADPONL-01 + Your own cable	

\*1 All GP models except AGP-3302B

\*2 Only the COM port which can communicate by RS-422/485 (4 wire) can be used.

 ■ COM Port of IPC (page 6)

\*3 All GP models except GP-3200 series and AGP-3302B



A) When using the COM port conversion adapter (CA3-ADPCOM-01), the terminal block conversion adapter (CA3-ADPTRM-01) by Pro-face and your own cable

- 1:1 Connection

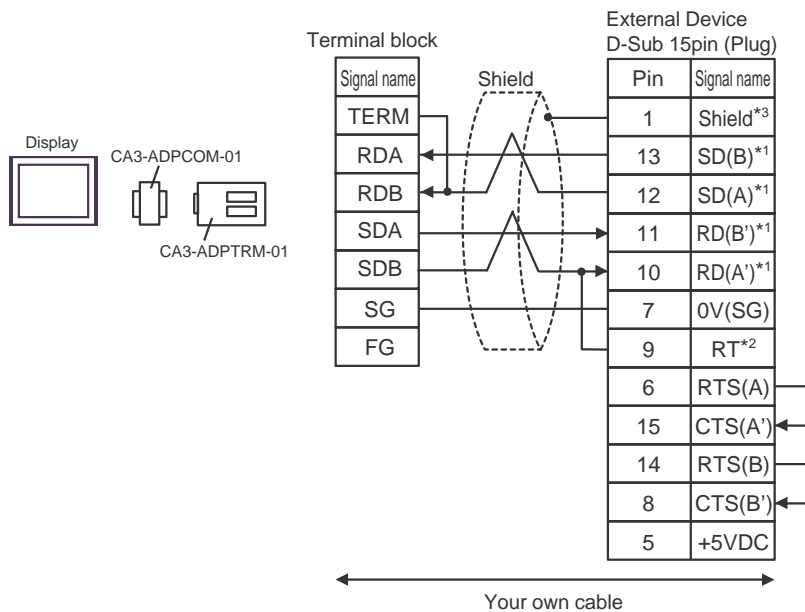

- 1:n Connection

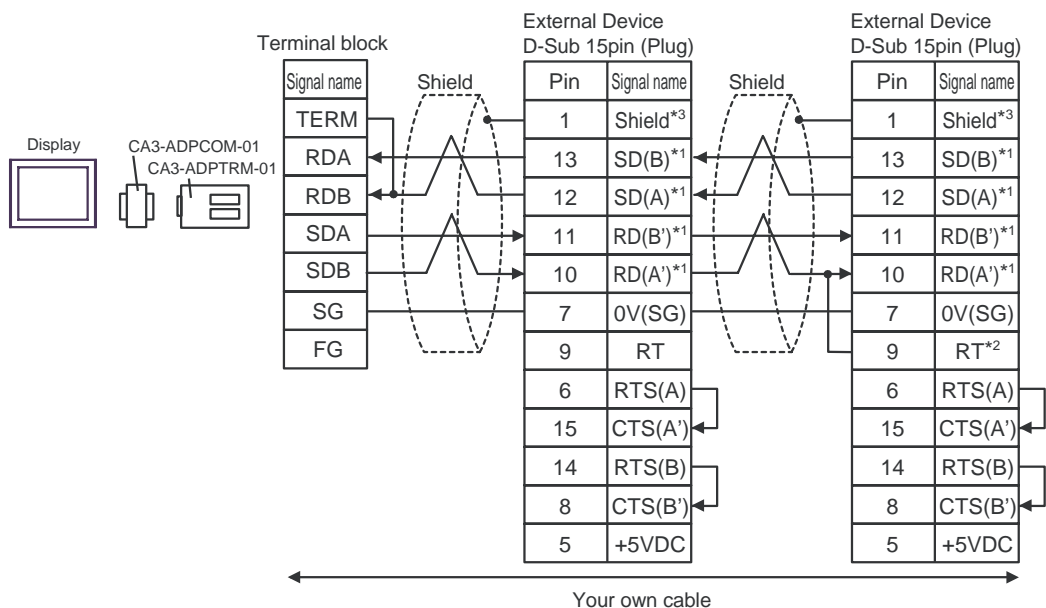

\*1: Notation of RD(A'), RD(B'), SD(A) and SD(B) are different by the external device.

Please refer to the manual of the external device.

In addition, please warn the naming of A class and B class is reversed to the display with the external device.

\*2: Insert the termination resistance of the external device side. The 120 Ω termination resistance is inserted between RDA - RDB by connecting the 9th pin to the 10th pin of serial interface at the external device side.

\*3: FG of the external device ground the D class grounding. In addition, FG connection to a shield line select the external device side, either display side by location environment.

## B) When using your own cable

- 1:1 Connection

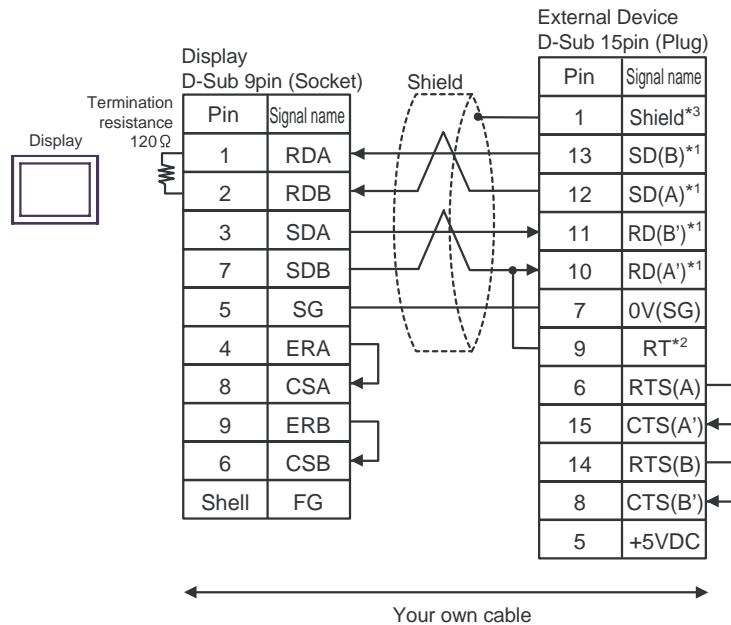

- 1:n Connection

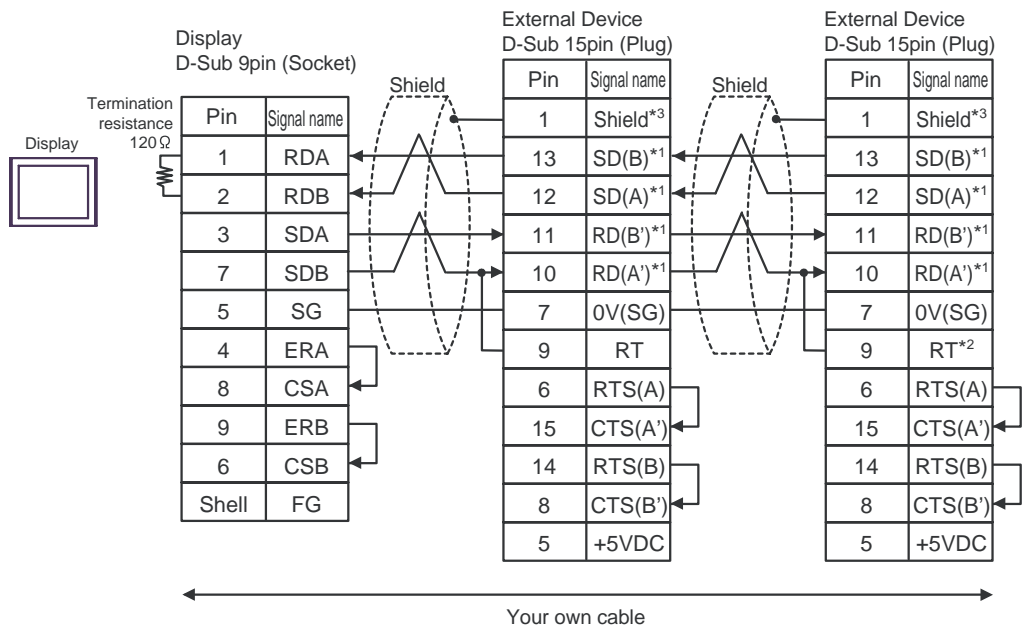

\*1: Notation of RD(A'), RD(B'), SD(A) and SD(B) are different by the external device.

Please refer to the manual of the external device.

In addition, please warn the naming of A class and B class is reversed to the display with the external device.

\*2: Insert the termination resistance of the external device side. The 120 Ω termination resistance is inserted between RDA - RDB by connecting the 9th pin to the 10th pin of serial interface at the external device side.

\*3: FG of the external device ground the D class grounding. In addition, FG connection to a shield line select the external device side, either display side by location environment.

C) When using the online adapter (CA4-ADPONL-01), the terminal block conversion adapter (CA3-ADPTRM-01) by Pro-face and your own cable

- 1:1 Connection

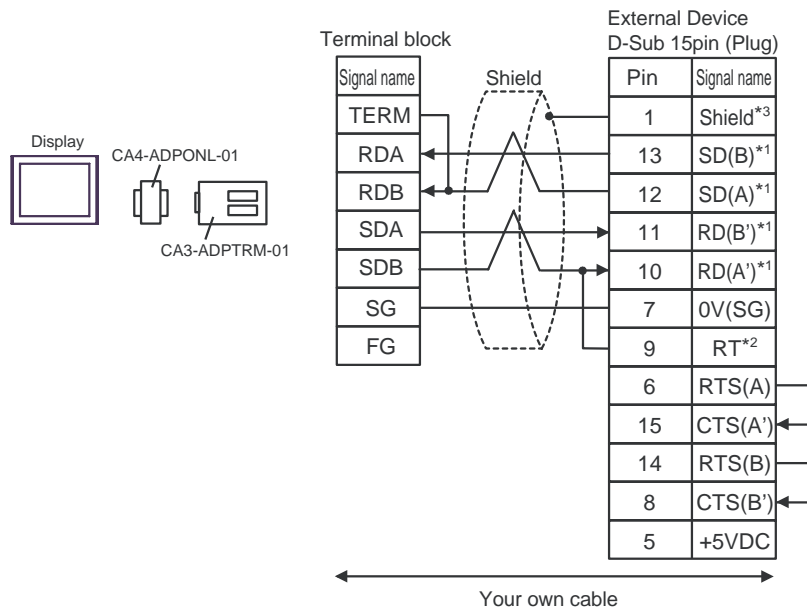

- 1:n Connection

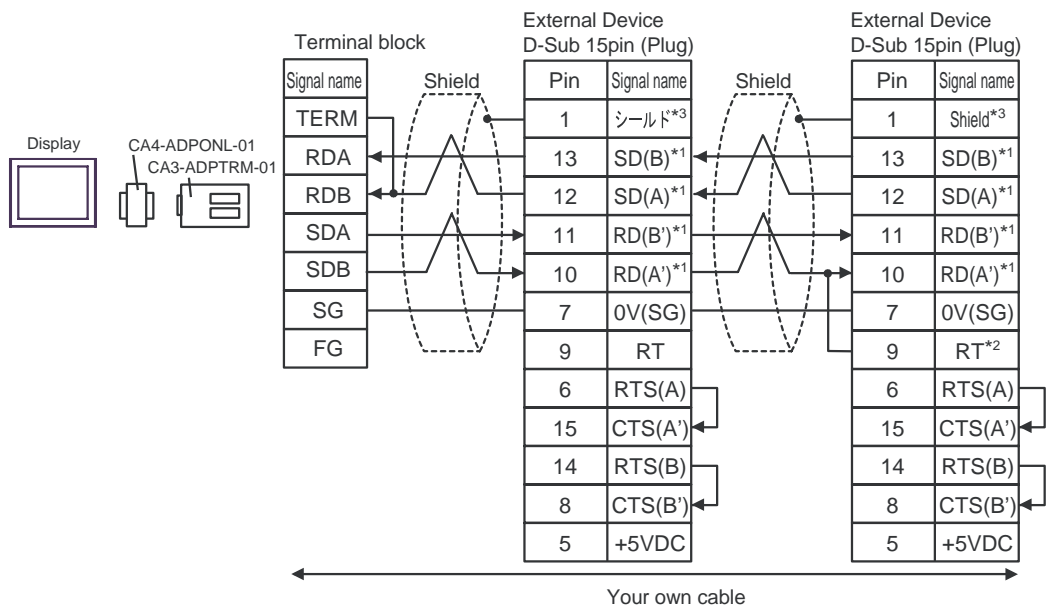

\*1: Notation of RD(A'), RD(B'), SD(A) and SD(B) are different by the external device.

Please refer to the manual of the external device.

In addition, please warn the naming of A class and B class is reversed to the display with the external device.

\*2: Insert the termination resistance of the external device side. The 120 Ω termination resistance is inserted between RDA - RDB by connecting the 9th pin to the 10th pin of serial interface at the external device side.

\*3: FG of the external device ground the D class grounding. In addition, FG connection to a shield line select the external device side, either display side by location environment.

D) When using the online adapter (CA4-ADPONL-01) by Pro-face and your own cable

- 1:1 Connection

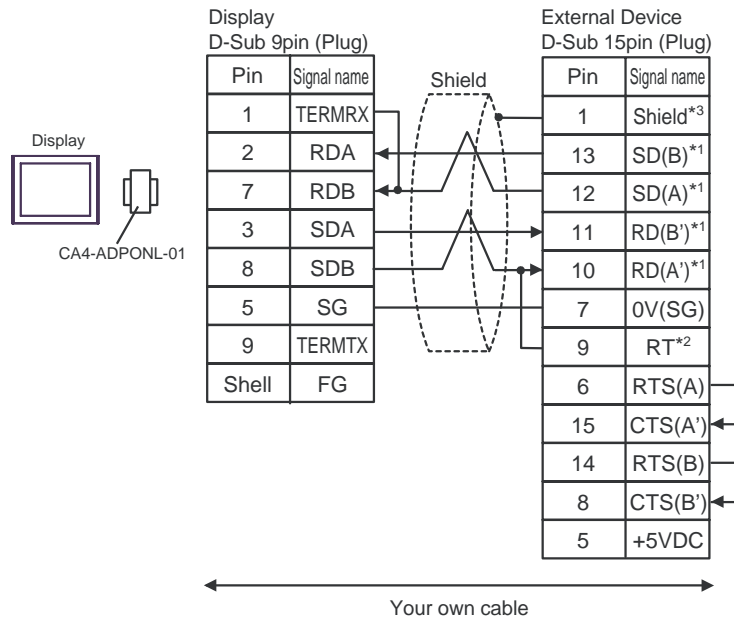

- 1:n Connection

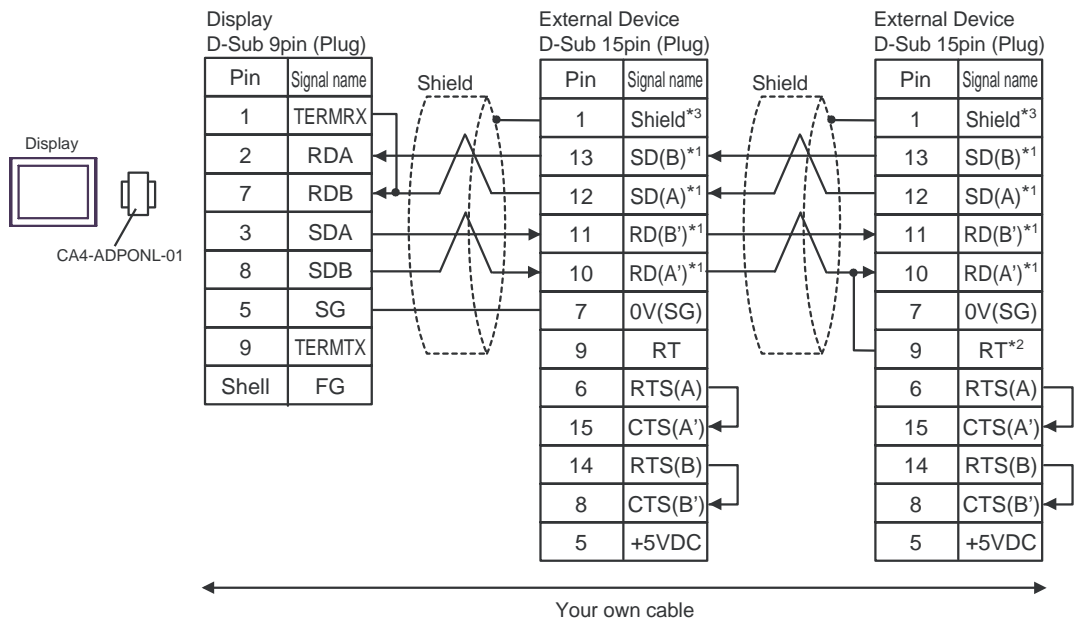

\*1: Notation of RD(A'), RD(B'), SD(A) and SD(B) are different by the external device.

Please refer to the manual of the external device.

In addition, please warn the naming of A class and B class is reversed to the display with the external device.

\*2: Insert the termination resistance of the external device side. The 120 Ω termination resistance is inserted between RDA - RDB by connecting the 9th pin to the 10th pin of serial interface at the external device side.

\*3: FG of the external device ground the D class grounding. In addition, FG connection to a shield line select the external device side, either display side by location environment.

Cable Diagram 2

Display (Connection Port)	Cable	Notes
GP (COM1) IPC*1	Your own cable	The cable length must be 15m or less.

\*1 Only the COM port which can communicate by RS-232C can be used.

☞ ■ COM Port of IPC (page 6)

When using your own cable

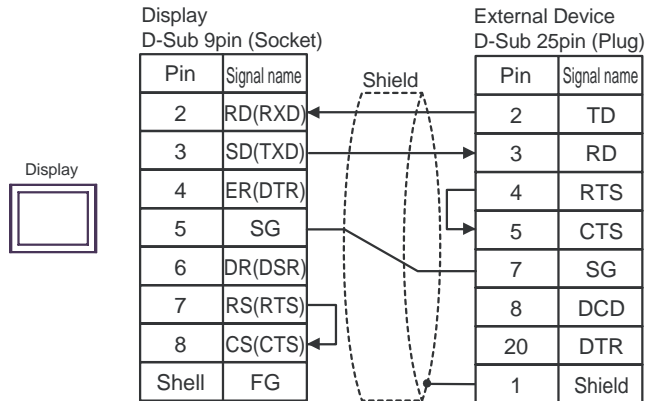

Cable Diagram 3

Display (Connection Port)	Cable		Notes
GP* <sup>1</sup> (COM1) AGP-3302B (COM2) IPC* <sup>2</sup>	A	COM port conversion adapter by Pro-face CA3-ADPCOM-01 + Terminal block conversion adapter by Pro-face CA3-ADPTRM-01 + Your own cable	The cable length must be 1000m or less.
	B	Your own cable	
GP* <sup>3</sup> (COM2)	C	Online adapter by Pro-face CA4-ADPONL-01 + Terminal block conversion adapter by Pro-face CA3-ADPTRM-01 + Your own cable	
	D	Online adapter by Pro-face CA4-ADPONL-01 + Your own cable	

\*1 All GP models except AGP-3302B

\*2 Only the COM port which can communicate by RS-422/485 (4 wire) can be used.

 ■ COM Port of IPC (page 6)

\*3 All GP models except GP-3200 series and AGP-3302B

A) When using the COM port conversion adapter (CA3-ADPCOM-01), the terminal block conversion adapter (CA3-ADPTRM-01) by Pro-face and your own cable

- 1:1 Connection

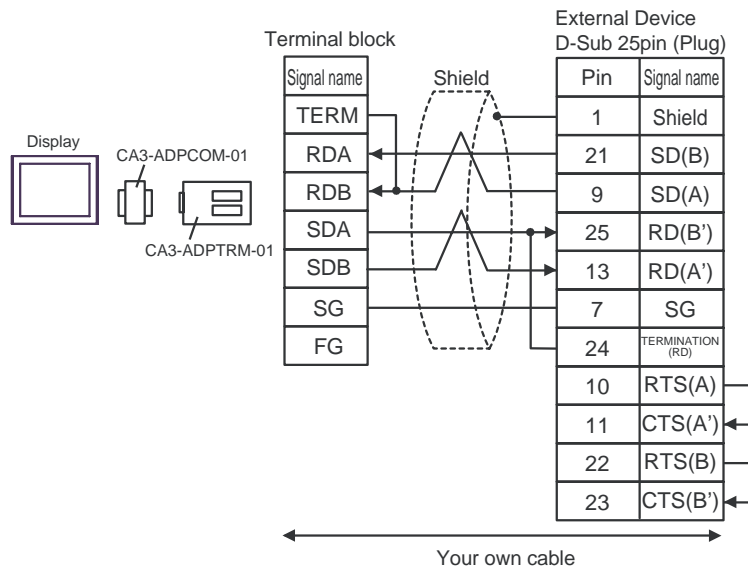

- 1:n Connection

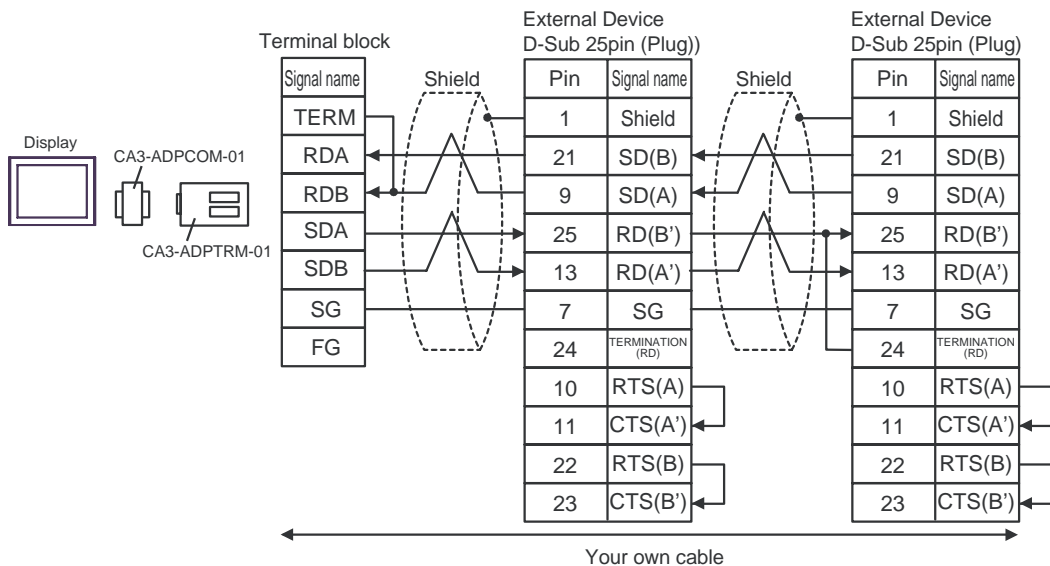

\*1: Notation of RD(A'), RD(B'), SD(A) and SD(B) are different by the external device.

Please refer to the manual of the external device.

In addition, please warn the naming of A class and B class is reversed to the display with the external device.

\*2: Insert the termination resistance of the external device side. The 120 Ω termination resistance is inserted between RDA - RDB by connecting the 9th pin to the 10th pin of serial interface at the external device side. But termination resistance is inserted in CPU731 and CPU771 by connecting the 9th pin to the 11th pin.

\*3: FG of the external device ground the D class grounding. In addition, FG connection to a shield line select the external device side, either display side by location environment.

## B) When using your own cable

- 1:1 Connection

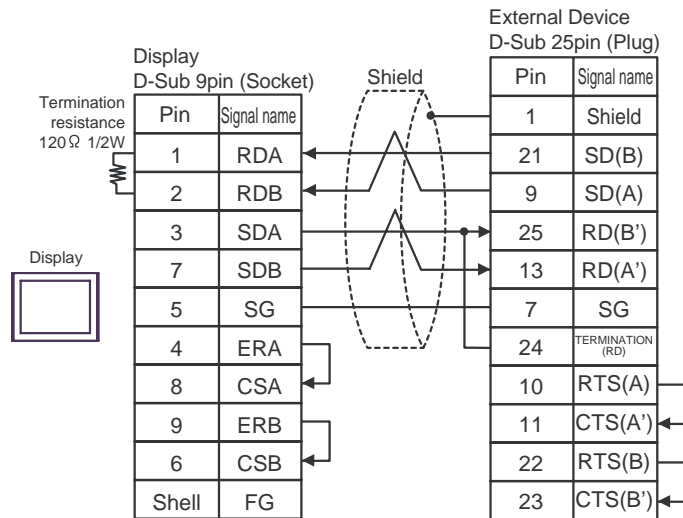

- 1:n Connection

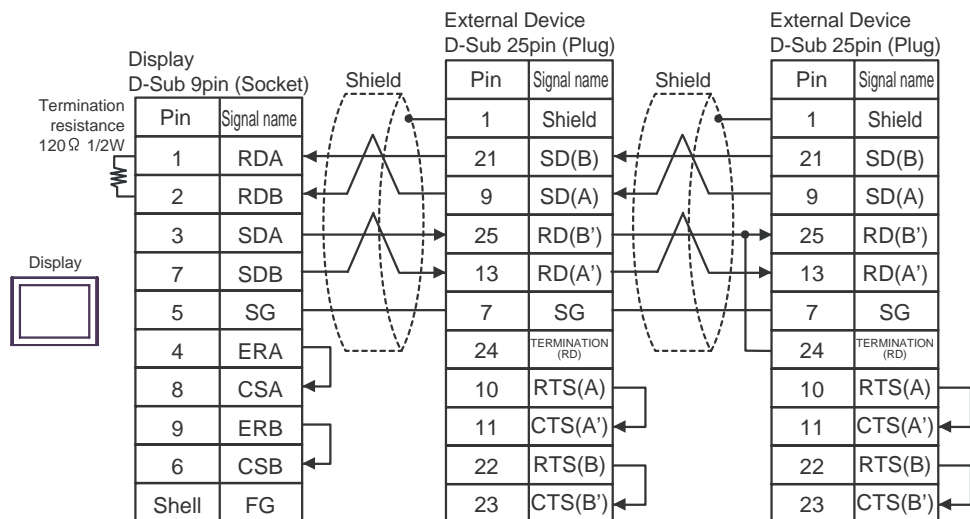

\*1: Notation of RD(A'), RD(B'), SD(A) and SD(B) are different by the external device.

Please refer to the manual of the external device.

In addition, please warn the naming of A class and B class is reversed to the display with the external device.

\*2: Insert the termination resistance of the external device side. The 120 Ω termination resistance is inserted between RDA - RDB by connecting the 9th pin to the 10th pin of serial interface at the external device side. But termination resistance is inserted in CPU731 and CPU771 by connecting the 9th pin to the 11th pin.

\*3: FG of the external device ground the D class grounding. In addition, FG connection to a shield line select the external device side, either display side by location environment.



C) When using the online adapter (CA4-ADPONL-01), the terminal block conversion adapter (CA3-ADPTRM-01) by Pro-face and your own cable

- 1:1 Connection

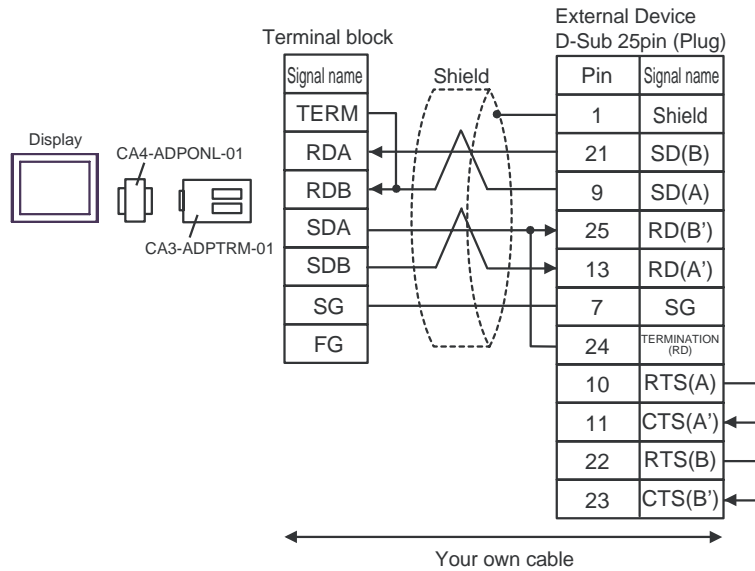

- 1:n Connection

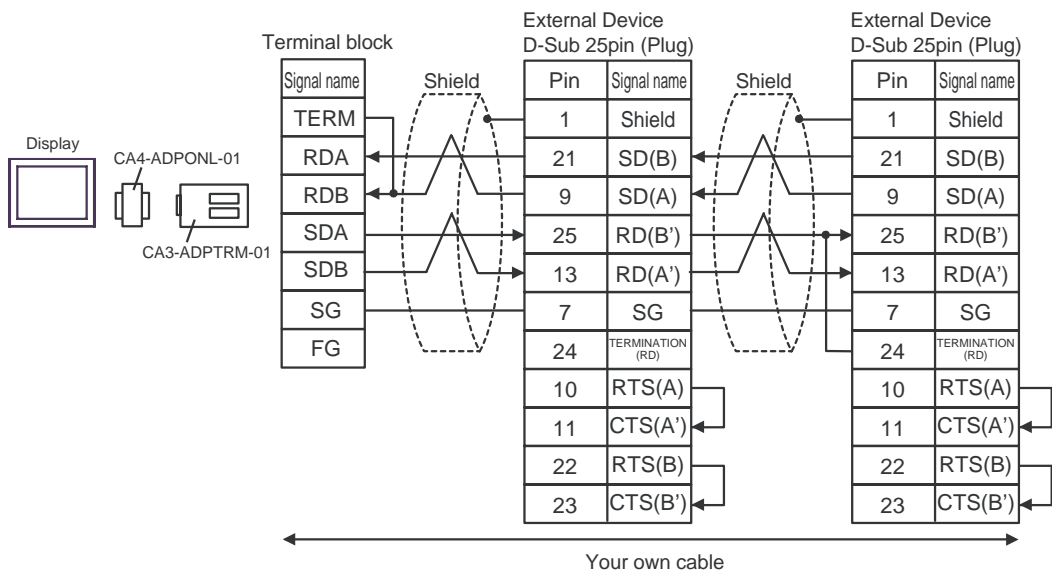

\*1: Notation of RD(A'), RD(B'), SD(A) and SD(B) are different by the external device.

Please refer to the manual of the external device.

In addition, please warn the naming of A class and B class is reversed to the display with the external device.

\*2: Insert the termination resistance of the external device side. The 120 Ω termination resistance is inserted between RDA - RDB by connecting the 9th pin to the 10th pin of serial interface at the external device side. But termination resistance is inserted in CPU731 and CPU771 by connecting the 9th pin to the 11th pin.

\*3: FG of the external device ground the D class grounding. In addition, FG connection to a shield line select the external device side, either display side by location environment.

D) When using the online adapter (CA4-ADPONL-01) by Pro-face and your own cable

- 1:1 Connection

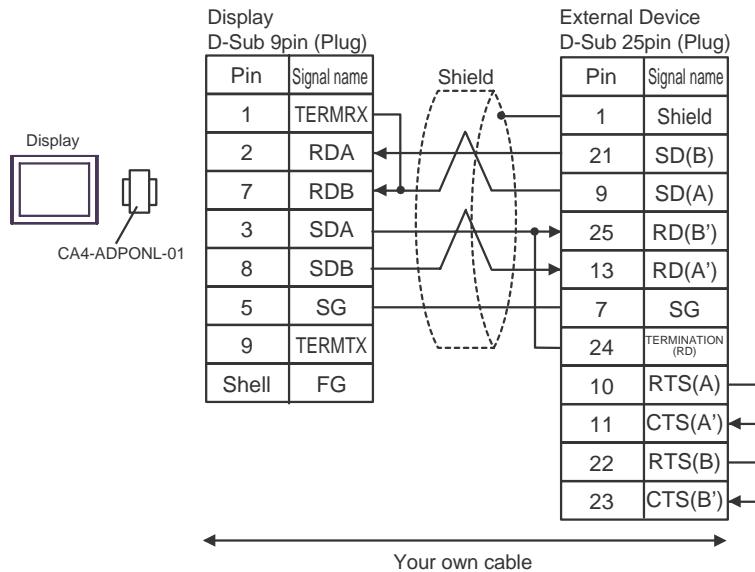

- 1:n Connection

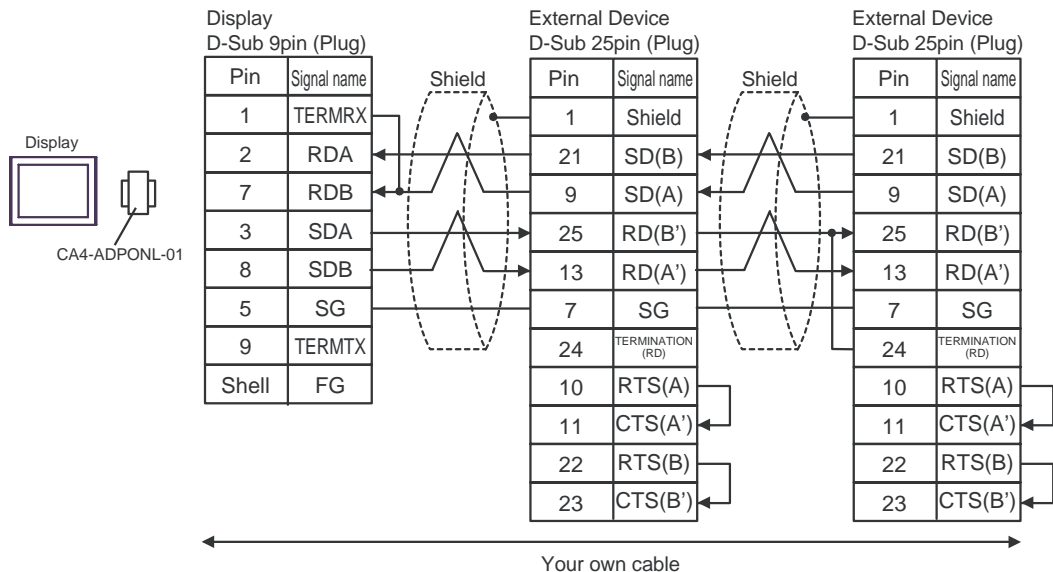

\*1: Notation of RD(A'), RD(B'), SD(A) and SD(B) are different by the external device.

Please refer to the manual of the external device.

In addition, please warn the naming of A class and B class is reversed to the display with the external device.

\*2: Insert the termination resistance of the external device side. The 120 Ω termination resistance is inserted between RDA - RDB by connecting the 9th pin to the 10th pin of serial interface at the external device side. But termination resistance is inserted in CPU731 and CPU771 by connecting the 9th pin to the 11th pin.

\*3: FG of the external device ground the D class grounding. In addition, FG connection to a shield line select the external device side, either display side by location environment.

Cable Diagram 4

Display (Connection Port)	Cable	Notes
GP (COM1) IPC*1	Your own cable	The cable length must be 15m or less.

\*1 Only the COM port which can communicate by RS-232C can be used.

☞ ■ COM Port of IPC (page 6)

When using your own cable

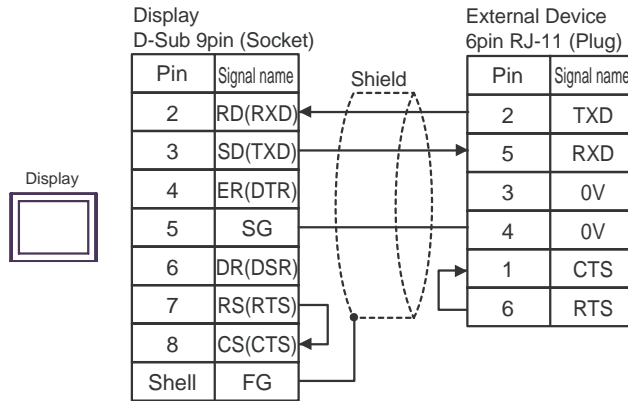

Cable Diagram 5

Display (Connection Port)	Cable	Notes
GP (COM1) IPC*1	Your own cable	The cable length must be 15m or less.

\*1 Only the COM port which can communicate by RS-232C can be used.

☞ ■ COM Port of IPC (page 6)



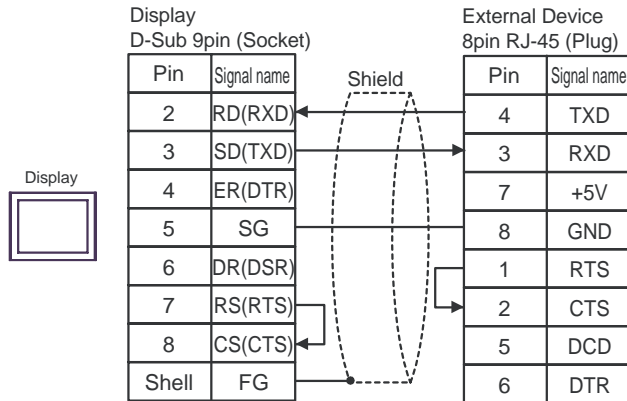



When using your own cable



## 6 Supported Device

Range of supported device address is shown in the table below. Please note that the actually supported range of the devices varies depending on the External Device to be used. Please check the actual range in the manual of your connecting equipment.

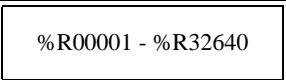
 This address can be specified as system data area.

Device	Bit Address	Word Address	32 bits	Notes
Discrete inputs	%I00001 - %I12288	%I00001 - %I12273		
Discrete outputs	%Q00001 - %Q12288	%Q00001 - %Q12273		
Discrete Globals	%G0001 - %G7680	%G0001 - %G7665		
Internal coils	%M00001 - %M12288	%M0001 - %M12273		
Temporary coils	%T001 - %T256	%T001 - %T241		
System status references	%S001 - %S128	%S001 - %S113		 *1
	%SA001 - %SA128	%SA001 - %SA113		
	%SB001 - %SB128	%SB001 - %SB113		
	%SC001 - %SC128	%SC001 - %SC113		
System register references	-----	 %R00001 - %R32640		
Analog inputs	-----	%AI00001 - %AI32640		
Analog outputs	-----	%AQ00001 - %AQ32640		

\*1 Write disable

### NOTE

- Please refer to the GP-Pro EX Reference Manual for system data area.  
Cf. GP-Pro EX Reference Manual "Appendix 1.4 LS Area (only for direct access method)"
- Please refer to the precautions on manual notation for icons in the table.  
 "Manual Symbols and Terminology"

## 7 Device Code and Address Code

Use device code and address code when you select "Device Type & Address" for the address type in data displays.

Device	Device Name	Device Code (HEX)	Address Code
Discrete inputs	%I	0080	(Word address - 1) / 16
Discrete outputs	%Q	0081	(Word address - 1) / 16
Discrete Globals	%M	0083	(Word address - 1) / 16
Internal coils	%G	0082	(Word address - 1) / 16
Temporary coils	%T	0084	(Word address - 1) / 16
System status references	%SA	0086	(Word address - 1) / 16
	%SB	0087	(Word address - 1) / 16
	%SC	0088	(Word address - 1) / 16
	%S	0085	(Word address - 1) / 16
System register references	%R	0000	Word address - 1
Analog inputs	%AI	0001	Word address - 1
Analog outputs	%AQ	0002	Word address - 1

## 8 Error Messages

Error messages are displayed on the screen of Display as follows: "No. : Device Name: Error Message (Error Occurrence Area)". Each description is shown below.

Item	Description
No.	Error No.
Device Name	Name of External Device where error occurs. Device name is a title of External Device set with GP-Pro EX. (Initial value [PLC1])
Error Message	Displays messages related to the error which occurs.
Error Occurrence Area	Displays IP address or device address of External Device where error occurs, or error codes received from External Device. <div style="border: 1px solid black; padding: 2px; margin: 5px 0;"><b>NOTE</b></div> <ul style="list-style-type: none"> <li>IP address is displayed such as "IP address (Decimal): MAC address (Hex)".</li> <li>Device address is displayed such as "Address: Device address".</li> <li>Received error codes are displayed such as "Decimal [Hex]".</li> </ul>

Display Examples of Error Messages

"RHAA035: PLC1: Error has been responded for device write command (Error Code: 2 [02H])"

**NOTE**

- Please refer to the manual of External Device for more detail of received error codes.
- Please refer to "When an error message is displayed (Error code list)" of "Maintenance/Troubleshooting" for a common error message to the driver.

### ■ Error Code Peculiar to External Device

The error code characteristic of the external device is displayed in 2 Byte of "Major Error Status Code (1 Byte)" and "Minor Error Status Code (1 Byte)".

When received the error code from the external device, add to the below message. "Major Error Status Code" is displayed continuously "Major" and "Minor Error Status Code" is displayed continuously "Minor".

For details of the error code, please refer to the manual of the external device.

The error code peculiar to the external device is as follows.

Message ID	Error Message	Description
RHxx128	(Node Name): Error has been responded for initial communication command (Major:[%02Xh], Minor:[%02Xh])	Display the error message, when the error occurred by the reading demand.
RHxx129	(Node Name): Error has been responded for device read command (Major:[%02Xh], Minor:[%02Xh])	Display the error message, when the error occurred by the reading demand.
RHxx130	(Node Name): Error has been responded for device write command (Major:[%02Xh], Minor:[%02Xh])	Display the error message, when the error occurred by the write demand.
RHxx131	(Node Name): Error has been responded for device write command (Major:[%02Xh], Minor:[%02Xh] There are read only devises)	Display the error message, when write for the read only device.

