



Master-K Series Cnet Driver

1	System Configuration.....	3
2	Selection of External Device	5
3	Example of Communication Setting.....	6
4	Setup Items.....	36
5	Cable Diagram	41
6	Supported Device.....	52
7	Device Code and Address Code.....	53
8	Error Messages.....	54

Introduction

This manual describes how to connect the Display (GP3000 series) and the External Device (target PLC).

In this manual, the connection procedure will be described by following the below sections:

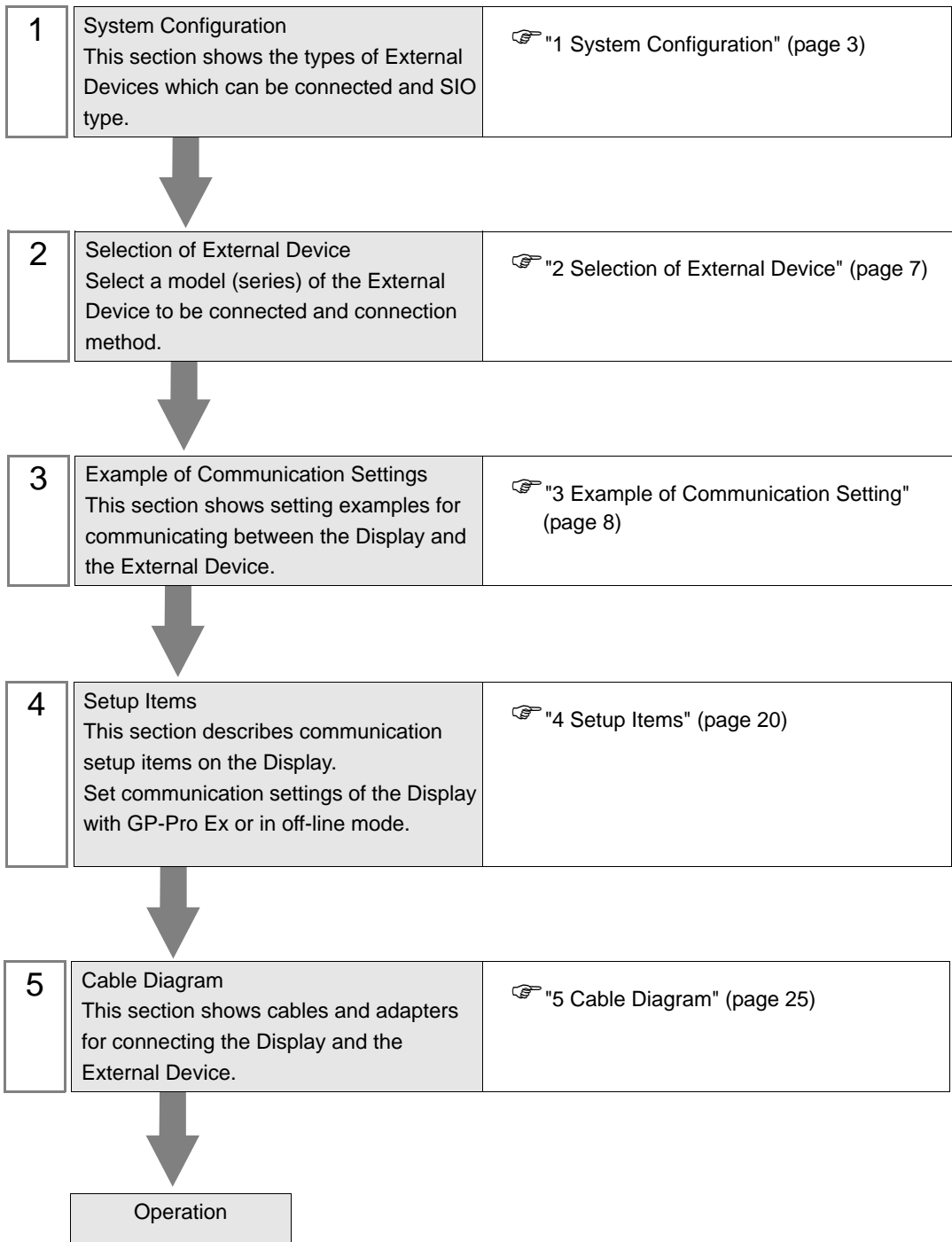

1 System Configuration

The system configuration in the case when the External Device of LS Industrial Systems and the Display are connected is shown.

Series	CPU	Link I/F	SIO Type	Setting Example	Cable Diagram
K1000S	K7P-30AS	G3L-CUEA (K7F-CUEA)* ¹	RS232C	Setting Example 1 (page 6)	Cable Diagram 1 (page 41)
			RS422/485 (4 wire)	Setting Example 2 (page 8)	Cable Diagram 2 (page 42)
			RS422/485 (2 wire)	Setting Example 3 (page 10)	Cable Diagram 3 (page 47)
K300S	K4P-15AS	G4L-CUEA (K4F-CUEA)* ¹	RS232C	Setting Example 1 (page 6)	Cable Diagram 1 (page 41)
			RS422/485 (4 wire)	Setting Example 2 (page 8)	Cable Diagram 2 (page 42)
			RS422/485 (2 wire)	Setting Example 3 (page 10)	Cable Diagram 3 (page 47)
K200S	K3P-07AS K3P-07BS K3P-07CS	G6L-CUEB (K3F-CU2A)* ¹	RS232C	Setting Example 4 (page 12)	Cable Diagram 1 (page 41)
		G6L-CUEC (K3F-CU4A)* ¹	RS422/485 (4 wire)	Setting Example 5 (page 14)	Cable Diagram 2 (page 42)
			RS422/485 (2 wire)	Setting Example 6 (page 16)	Cable Diagram 3 (page 47)
K120S	K7M-DR(T)20U K7M-DR(T)30U K7M-DR(T)40U K7M-DR(T)60U K7M-DT20U K7M-DT30U K7M-DT40U K7M-DT60U	Port1 on CPU unit	RS232C	Setting Example 7 (page 18)	Cable Diagram 4 (page 49)
		Port2 on CPU unit	RS422/485 (2 wire)	Setting Example 8 (page 20)	Cable Diagram 5 (page 50)
		G7L-CUEB	RS232C	Setting Example 9 (page 22)	Cable Diagram 1 (page 41)
		G7L-CUEC	RS422/485 (4 wire)	Setting Example 10 (page 24)	Cable Diagram 2 (page 42)
			RS422/485 (2 wire)	Setting Example 11 (page 26)	Cable Diagram 3 (page 47)
			RS422/485 (2 wire)	Setting Example 11 (page 26)	Cable Diagram 3 (page 47)
K80S	K7M-DR10S(/DC) K7M-DR20S(/DC) K7M-DR30S(/DC) K7M-DR40S(/DC) K7M-DR60S(/DC) K7M-DT10S K7M-DT20S K7M-DT30S K7M-DT40S K7M-DT60S	Port on CPU unit	RS232C	Setting Example 12 (page 28)	Cable Diagram 4 (page 49)
		G7L-CUEB	RS232C	Setting Example 13 (page 30)	Cable Diagram 1 (page 41)
		G7L-CUEC	RS422/485 (4 wire)	Setting Example 14 (page 32)	Cable Diagram 2 (page 42)
			RS422/485 (2 wire)	Setting Example 15 (page 34)	Cable Diagram 3 (page 47)

*1 The module of parenthesis is a old name.

■ Connection Configuration

- 1:1 Connection



- 1:n Connection (RS422/485 (4 wire))

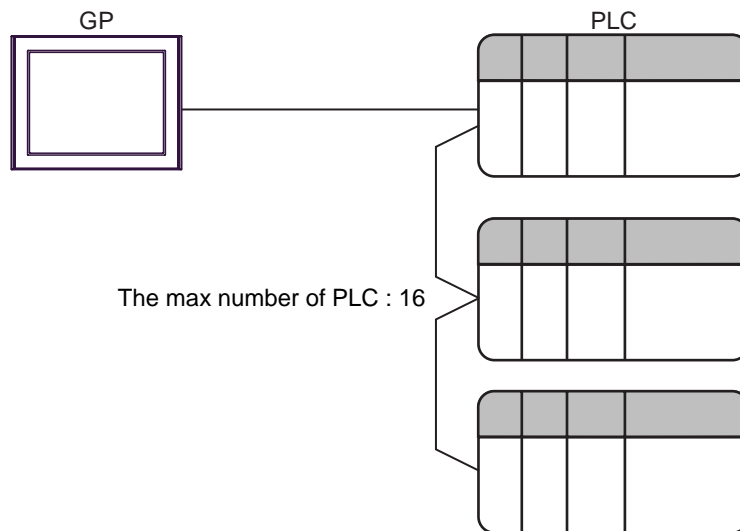

2 Selection of External Device

Select the External Device to be connected to the Display.

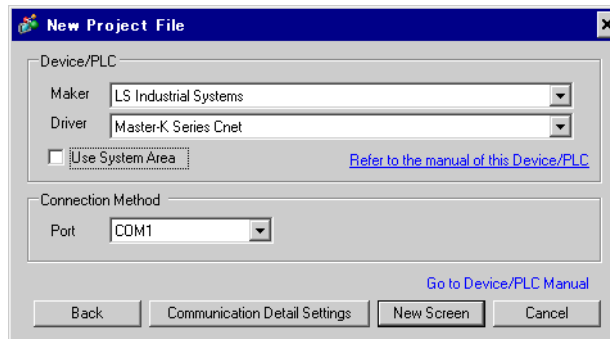

Setup Items	Setup Description
Maker	Select the maker of the External Device to be connected. Select "LS Industrial Systems".
Driver	Select a model (series) of the External Device to be connected and connection method. Select "Master-K series Cnet". Check the External Device which can be connected in "Master-K series Cnet" in system configuration. ☞ "1 System Configuration" (page 3)
Use System Area	Check this option when you synchronize the system data area of Display and the device (memory) of External Device. When synchronized, you can use the ladder program of External Device to switch the display or display the window on the display. Cf. GP-Pro EX Reference Manual "Appendix 1.4 LS Area (only for direct access method)" This can be also set with GP-Pro EX or in off-line mode of Display. Cf. GP-Pro EX Reference Manual " 6.13.6 Setting Guide of [System Setting Window]■[Main Unit Settings] Settings Guide◆System Area Setting" Cf. GP3000 Series User Manual "4.3.6 System Area Setting"
Port	Select the Display port to be connected to the External Device.

3 Example of Communication Setting

Examples of communication settings of the Display and the External Device, recommended by Pro-face, are shown.

3.1 Setting Example 1

■ Settings of GP-Pro EX

◆ Communication Settings

To display the setting screen, select [Device/PLC Settings] from [System setting window] in workspace.

◆ Device Setting

To display the setting screen, click  ([Setting]) of External Device you want to set from [Device-Specific Settings] of [Device/PLC Settings].

When you connect multiple External Device, click  from [Device-Specific Settings] of [Device/PLC Settings] to add another External Device.

■ Settings of External Device

Communication setting of external device by setup tool (Cnet Frame Editor).

Please refer to the manual of external device for more detail.

◆ Procedure

- 1 Connect RS-232C port on CPU unit of external device with the personal computer.
Refer to the manual of external device for the cable used.
- 2 Set Mode rotary SW in the Cnet module to "9" (On Line Mode), and turn on the power supply of external device again.
- 3 Start setup tool, and set the communication port.
Select [Port] of the [Option] menu, and set the port of external device connected with step 1 and the port of the personal computer.
- 4 Select [Connect] of the [Online] menu, and put it into the state that external device and personal computer can be communicated.
- 5 Set the communication setup of external device with setup tool.

Setup Items		Setup Description
Channel		RS232 side
Base Parameters	Station	00
	Type	Null Modem
	Baud Rate	38400
	Data Bit	8
	Parity	None
	Stop Bit	1

- 6 Select [Write] of the [Online] menu.
Set in the displayed dialog box, and click [Write].

Setup Items	Setup Description	Description
Slot No.	SLOT 0	Select the slot in which the Cnet module is installed.
Option	Basic Parameters	Select the written content. Select "Basic Parameters" here.

- 7 Select [Online Change Mode] of the [Online] menu.
Set in the displayed dialog box, and click [Write].

Setup Items	Setup Description	Description
Slot No.	SLOT 0	Select the slot in which the Cnet module is installed.
Channel	Stand Alone	
RS-232C	Dedicated Mode	

- 8 Select [Change RUN/STOP] of the [Online] menu, and put external device into the state of RUN.

Setup Items	Setup Description	Description
Slot No.	SLOT 0	Select the slot in which the Cnet module is installed.
Type	RS_232C	

- 9 Set Mode rotary SW in the Cnet module to "3" (Dedicated Mode), and turn on the power supply of external device again.

3.2 Setting Example 2

■ Settings of GP-Pro EX

◆ Communication Settings

To display the setting screen, select [Device/PLC Settings] from [System setting window] in workspace.

◆ Device Setting

To display the setting screen, click  ([Setting]) of External Device you want to set from [Device-Specific Settings] of [Device/PLC Settings].

When you connect multiple External Device, click  from [Device-Specific Settings] of [Device/PLC Settings] to add another External Device.

■ Settings of External Device

Communication setting of external device by setup tool (Cnet Frame Editor).

Please refer to the manual of external device for more detail.

◆ Procedure

- 1 Connect RS-232C port on CPU unit of external device with the personal computer.

Refer to the manual of external device for the cable used.

- 2 Set Mode rotary SW in the Cnet module to "9" (On Line Mode), and turn on the power supply of external device again.

- 3 Start setup tool, and set the communication port.

Select [Port] of the [Option] menu, and set the port of external device connected with step 1 and the port of the personal computer.

- 4 Select [Connect] of the [Online] menu, and put it into the state that external device and personal computer can be communicated.

- 5 Set the communication setup of external device with setup tool.

Setup Items		Setup Description
Channel		RS422 side
Base Parameters	Station	00
	Type	Null Modem
	Baud Rate	38400
	Data Bit	8
	Parity	None
	Stop Bit	1

- 6 Select [Write] of the [Online] menu.

Set in the displayed dialog box, and click [Write].

Setup Items	Setup Description	Description
Slot No.	SLOT 0	Select the slot in which the Cnet module is installed.
Option	Basic Parameters	Select the written content. Select "Basic Parameters" here.

- 7 Select [Online Change Mode] of the [Online] menu.

Set in the displayed dialog box, and click [Write].

Setup Items	Setup Description	Description
Slot No.	SLOT 0	Select the slot in which the Cnet module is installed.
Channel	Stand Alone	
RS-422	Dedicated Mode	

- 8 Select [Change RUN/STOP] of the [Online] menu, and put external device into the state of RUN.

Setup Items	Setup Description	Description
Slot No.	SLOT 0	Select the slot in which the Cnet module is installed.
Type	RS_422	

- 9 Set Mode rotary SW in the Cnet module to "3" (Dedicated Mode), and turn on the power supply of external device again.

3.3 Setting Example 3

■ Settings of GP-Pro EX

◆ Communication Settings

To display the setting screen, select [Device/PLC Settings] from [System setting window] in workspace.

Device/PLC 1

Summary [Change Device/PLC](#)

Maker Driver Port

Text Data Mode [Change](#)

Communication Settings

SIO Type RS232C RS422/485(2wire) RS422/485(4wire)

Speed

Data Length 7 8

Parity NONE EVEN ODD

Stop Bit 1 2

Flow Control NONE ER(DTR/CTS) XON/XOFF

Timeout (sec)

Retry

Wait To Send (ms)

RI / VCC RI VCC

In the case of RS232C, you can select the 9th pin to RI (Input or VCC (5V Power Supply). If you use the Digital's RS232C Isolation Unit, please select it to VCC.

Device-Specific Settings

Allowable No. of Device/PLCs: 16 Unit(s)

No.	Device Name	Settings
<input type="button" value="1"/>	<input type="text" value="PLC1"/>	<input type="text" value="Station=0"/>

◆ Device Setting

To display the setting screen, click ([Setting]) of External Device you want to set from [Device-Specific Settings] of [Device/PLC Settings].

When you connect multiple External Device, click from [Device-Specific Settings] of [Device/PLC Settings] to add another External Device.

Individual Device Settings

PLC1

Station

■ Settings of External Device

Communication setting of external device by setup tool (Cnet Frame Editor).

Please refer to the manual of external device for more detail.

◆ Procedure

- 1 Connect RS-232C port on CPU unit of external device with the personal computer.

Refer to the manual of external device for the cable used.

- 2 Set Mode rotary SW in the Cnet module to "9" (On Line Mode), and turn on the power supply of external device again.

- 3 Start setup tool, and set the communication port.

Select [Port] of the [Option] menu, and set the port of external device connected with step 1 and the port of the personal computer.

- 4 Select [Connect] of the [Online] menu, and put it into the state that external device and personal computer can be communicated.

- 5 Set the communication setup of external device with setup tool.

Setup Items		Setup Description
Channel		RS422 side
Base Parameters	Station	00
	Type	Null Modem
	Baud Rate	38400
	Data Bit	8
	Parity	None
	Stop Bit	1

- 6 Select [Write] of the [Online] menu.

Set in the displayed dialog box, and click [Write].

Setup Items	Setup Description	Description
Slot No.	SLOT 0	Select the slot in which the Cnet module is installed.
Option	Basic Parameters	Select the written content. Select "Basic Parameters" here.

- 7 Select [Online Change Mode] of the [Online] menu.

Set in the displayed dialog box, and click [Write].

Setup Items	Setup Description	Description
Slot No.	SLOT 0	Select the slot in which the Cnet module is installed.
Channel	Stand Alone	
RS-422	Dedicated Mode	

- 8 Select [Change RUN/STOP] of the [Online] menu, and put external device into the state of RUN.

Setup Items	Setup Description	Description
Slot No.	SLOT 0	Select the slot in which the Cnet module is installed.
Type	RS_422	

- 9 Set Mode rotary SW in the Cnet module to "3" (Dedicated Mode), and turn on the power supply of external device again.

3.4 Setting Example 4

■ Settings of GP-Pro EX

◆ Communication Settings

To display the setting screen, select [Device/PLC Settings] from [System setting window] in workspace.

◆ Device Setting

To display the setting screen, click  ([Setting]) of External Device you want to set from [Device-Specific Settings] of [Device/PLC Settings].

When you connect multiple External Device, click  from [Device-Specific Settings] of [Device/PLC Settings] to add another External Device.

■ Settings of External Device

Communication setting of external device by setup tool (Cnet Frame Editor).

Please refer to the manual of external device for more detail.

◆ Procedure

- 1 Connect RS-232C port on CPU unit of external device with the personal computer.

Refer to the manual of external device for the cable used.

- 2 Set Mode rotary SW in the Cnet module to "9" (On Line Mode), and turn on the power supply of external device again.

- 3 Start setup tool, and set the communication port.

Select [Port] of the [Option] menu, and set the port of external device connected with step 1 and the port of the personal computer.

- 4 Select [Connect] of the [Online] menu, and put it into the state that external device and personal computer can be communicated.

- 5 Set the communication setup of external device with setup tool.

Setup Items		Setup Description
Channel		RS232 side
Base Parameters	Station	00
	Type	Null Modem
	Baud Rate	38400
	Data Bit	8
	Parity	None
	Stop Bit	1

- 6 Select [Write] of the [Online] menu.

Set in the displayed dialog box, and click [Write].

Setup Items	Setup Description	Description
Slot No.	SLOT 0	Select the slot in which the Cnet module is installed.
Option	Basic Parameters	Select the written content. Select "Basic Parameters" here.

- 7 Select [Online Change Mode] of the [Online] menu.

Set in the displayed dialog box, and click [Write].

Setup Items	Setup Description	Description
Slot No.	SLOT 0	Select the slot in which the Cnet module is installed.
Channel	Stand Alone	
RS-232C	Dedicated Mode	

- 8 Select [Change RUN/STOP] of the [Online] menu, and put external device into the state of RUN.

Setup Items	Setup Description	Description
Slot No.	SLOT 0	Select the slot in which the Cnet module is installed.
Type	RS_232C	

- 9 Set Mode rotary SW in the Cnet module to "1" (Dedicated Mode), and turn on the power supply of external device again.

3.5 Setting Example 5

■ Settings of GP-Pro EX

◆ Communication Settings

To display the setting screen, select [Device/PLC Settings] from [System setting window] in workspace.

Device/PLC 1

Summary [Change Device/PLC](#)

Maker Driver Port

Text Data Mode [Change](#)

Communication Settings

SIO Type RS232C RS422/485(2wire) RS422/485(4wire)

Speed

Data Length 7 8

Parity NONE EVEN ODD

Stop Bit 1 2

Flow Control NONE ER(DTR/CTS) XON/XOFF

Timeout (sec)

Retry

Wait To Send (ms)

RI / VCC RI VCC

In the case of RS232C, you can select the 9th pin to RI (Input or VCC (5V Power Supply). If you use the Digital's RS232C Isolation Unit, please select it to VCC.

Device-Specific Settings

Allowable No. of Device/PLCs: 16 Unit(s)

No.	Device Name	Settings
1	PLC1	Station=0

◆ Device Setting

To display the setting screen, click ([Setting]) of External Device you want to set from [Device-Specific Settings] of [Device/PLC Settings].

When you connect multiple External Device, click from [Device-Specific Settings] of [Device/PLC Settings] to add another External Device.

Individual Device Settings

PLC1

Station

■ Settings of External Device

Communication setting of external device by setup tool (Cnet Frame Editor).

Please refer to the manual of external device for more detail.

◆ Procedure

- 1 Connect RS-232C port on CPU unit of external device with the personal computer.

Refer to the manual of external device for the cable used.

- 2 Set Mode rotary SW in the Cnet module to "9" (On Line Mode), and turn on the power supply of external device again.

- 3 Start setup tool, and set the communication port.

Select [Port] of the [Option] menu, and set the port of external device connected with step 1 and the port of the personal computer.

- 4 Select [Connect] of the [Online] menu, and put it into the state that external device and personal computer can be communicated.

- 5 Set the communication setup of external device with setup tool.

Setup Items		Setup Description
Channel		RS422 side
Base Parameters	Station	00
	Type	Null Modem
	Baud Rate	38400
	Data Bit	8
	Parity	None
	Stop Bit	1

- 6 Select [Write] of the [Online] menu.

Set in the displayed dialog box, and click [Write].

Setup Items	Setup Description	Description
Slot No.	SLOT 0	Select the slot in which the Cnet module is installed.
Option	Basic Parameters	Select the written content. Select "Basic Parameters" here.

- 7 Select [Online Change Mode] of the [Online] menu.

Set in the displayed dialog box, and click [Write].

Setup Items	Setup Description	Description
Slot No.	SLOT 0	Select the slot in which the Cnet module is installed.
Channel	Stand Alone	
RS-422	Dedicated Mode	

- 8 Select [Change RUN/STOP] of the [Online] menu, and put external device into the state of RUN.

Setup Items	Setup Description	Description
Slot No.	SLOT 0	Select the slot in which the Cnet module is installed.
Type	RS_422	

- 9 Set Mode rotary SW in the Cnet module to "1" (Dedicated Mode), and turn on the power supply of external device again.

3.6 Setting Example 6

■ Settings of GP-Pro EX

◆ Communication Settings

To display the setting screen, select [Device/PLC Settings] from [System setting window] in workspace.

Device/PLC 1

Summary [Change Device/PLC](#)

Maker Driver Port

Text Data Mode [Change](#)

Communication Settings

SIO Type RS232C RS422/485(2wire) RS422/485(4wire)

Speed

Data Length 7 8

Parity NONE EVEN ODD

Stop Bit 1 2

Flow Control NONE ER(DTR/CTS) XON/XOFF

Timeout (sec)

Retry

Wait To Send (ms)

RI / VCC RI VCC

In the case of RS232C, you can select the 9th pin to RI (Input or VCC (5V Power Supply). If you use the Digital's RS232C Isolation Unit, please select it to VCC.

Device-Specific Settings

Allowable No. of Device/PLCs: 16 Unit(s)

No.	Device Name	Settings
1	PLC1	Station=0

◆ Device Setting

To display the setting screen, click ([Setting]) of External Device you want to set from [Device-Specific Settings] of [Device/PLC Settings].

When you connect multiple External Device, click from [Device-Specific Settings] of [Device/PLC Settings] to add another External Device.

Individual Device Settings

PLC1

Station

■ Settings of External Device

Communication setting of external device by setup tool (Cnet Frame Editor).

Please refer to the manual of external device for more detail.

◆ Procedure

- 1 Connect RS-232C port on CPU unit of external device with the personal computer.

Refer to the manual of external device for the cable used.

- 2 Set Mode rotary SW in the Cnet module to "9" (On Line Mode), and turn on the power supply of external device again.

- 3 Start setup tool, and set the communication port.

Select [Port] of the [Option] menu, and set the port of external device connected with step 1 and the port of the personal computer.

- 4 Select [Connect] of the [Online] menu, and put it into the state that external device and personal computer can be communicated.

- 5 Set the communication setup of external device with setup tool.

Setup Items		Setup Description
Channel		RS422 side
Base Parameters	Station	00
	Type	Null Modem
	Baud Rate	38400
	Data Bit	8
	Parity	None
	Stop Bit	1

- 6 Select [Write] of the [Online] menu.

Set in the displayed dialog box, and click [Write].

Setup Items	Setup Description	Description
Slot No.	SLOT 0	Select the slot in which the Cnet module is installed.
Option	Basic Parameters	Select the written content. Select "Basic Parameters" here.

- 7 Select [Online Change Mode] of the [Online] menu.

Set in the displayed dialog box, and click [Write].

Setup Items	Setup Description	Description
Slot No.	SLOT 0	Select the slot in which the Cnet module is installed.
Channel	Stand Alone	
RS-422	Dedicated Mode	

- 8 Select [Change RUN/STOP] of the [Online] menu, and put external device into the state of RUN.

Setup Items	Setup Description	Description
Slot No.	SLOT 0	Select the slot in which the Cnet module is installed.
Type	RS_422	

- 9 Set Mode rotary SW in the Cnet module to "1" (Dedicated Mode), and turn on the power supply of external device again.

3.7 Setting Example 7

■ Settings of GP-Pro EX

◆ Communication Settings

To display the setting screen, select [Device/PLC Settings] from [System setting window] in workspace.

Device/PLC 1

Summary [Change Device/PLC](#)

Maker LS Industrial Systems Driver Master-K Series Cnet Port COM1

Text Data Mode 2 [Change](#)

Communication Settings

SIO Type RS232C RS422/485(2wire) RS422/485(4wire)

Speed 38400

Data Length 7 8

Parity NONE EVEN ODD

Stop Bit 1 2

Flow Control NONE ER(DTR/CTS) XON/XOFF

Timeout 3 (sec)

Retry 2

Wait To Send 0 (ms)

RI / VCC RI VCC

In the case of RS232C, you can select the 9th pin to RI (Input) or VCC (5V Power Supply). If you use the Digital's RS232C Isolation Unit, please select it to VCC.

Default

Device-Specific Settings

Allowable No. of Device/PLCs: 16 Unit(s)

No.	Device Name	Settings
1	PLC1	Station=0

◆ Device Setting

To display the setting screen, click ([Setting]) of External Device you want to set from [Device-Specific Settings] of [Device/PLC Settings].

When you connect multiple External Device, click from [Device-Specific Settings] of [Device/PLC Settings] to add another External Device.

Individual Device Settings

PLC1

Station 0

Default

OK (O) Cancel

■ Settings of External Device

Communication setting of external device by ladder software (KGL_WIN).

Please refer to the manual of external device for more detail.

◆ Procedure

- 1 Connect RS-232C port on CPU unit of external device with the personal computer.
Turn ON the [BUILT_IN CNET] switch.
Refer to the manual of external device for the cable used.
- 2 Start the ladder software, and make the project newly.
Select "120S" from [MK_S] of [PLC Type].
- 3 Double-click [Parameter] of the tree view and display the [Parameter] dialog box.
- 4 Click the [CommCh0] tab, and set the communication setup of external device.

Setup Items		Setup Description
Communication		Enable
Communication Method	Station Number	0
	Baud Rate	38400
	Data Bit	8
	Parity	None
	Stop Bit	1
	Communication Channel	RS232C Null Modem or RS422/485
Protocol and Mode	Dedicated	Slave

- 5 Select [Connect] of the [Online] menu.
- 6 Select [Write[KGL_WIN=>PLC]] of the [Online] menu, and download the communication setup of external device.

NOTE • When [Write[KGL_WIN=>PLC]] cannot be selected, it is necessary to stop driving external device.
Select [Change Mode] - [Stop] of the [Online] menu.

3.8 Setting Example 8

■ Settings of GP-Pro EX

◆ Communication Settings

To display the setting screen, select [Device/PLC Settings] from [System setting window] in workspace.

Device/PLC 1

Summary [Change Device/PLC](#)

Maker Driver Port

Text Data Mode [Change](#)

Communication Settings

SIO Type RS232C RS422/485(2wire) RS422/485(4wire)

Speed

Data Length 7 8

Parity NONE EVEN ODD

Stop Bit 1 2

Flow Control NONE ER(DTR/CTS) XON/XOFF

Timeout (sec)

Retry

Wait To Send (ms)

RI / VCC RI VCC

In the case of RS232C, you can select the 9th pin to RI (Input or VCC (5V Power Supply). If you use the Digital's RS232C Isolation Unit, please select it to VCC.

Device-Specific Settings

Allowable No. of Device/PLCs: 16 Unit(s)

No.	Device Name	Settings
<input type="button" value="1"/>	<input type="text" value="PLC1"/>	<input type="text" value="Station=0"/>

◆ Device Setting

To display the setting screen, click ([Setting]) of External Device you want to set from [Device-Specific Settings] of [Device/PLC Settings].

When you connect multiple External Device, click from [Device-Specific Settings] of [Device/PLC Settings] to add another External Device.

Individual Device Settings

PLC1

Station

■ Settings of External Device

Communication setting of external device by ladder software (KGL_WIN).

Please refer to the manual of external device for more detail.

◆ Procedure

- 1 Connect RS-485 port on CPU unit of external device with the personal computer.
Refer to the manual of external device for the cable used.
- 2 Start the ladder software, and make the project newly.
Select "120S" from [MK_S] of [PLC Type].
- 3 Double-click [Parameter] of the tree view and display the [Parameter] dialog box.
- 4 Click the [CommCh1] tab, and set the communication setup of external device.

Setup Items		Setup Description
Communication		Enable
Communication Method	Station Number	0
	Baud Rate	38400
	Data Bit	8
	Parity	None
	Stop Bit	1
	Communication Channel	RS485
Protocol and Mode	Dedicated	Slave

- 5 Select [Connect] of the [Online] menu.
- 6 Select [Write[KGL_WIN=>PLC]] of the [Online] menu, and download the communication setup of external device.

-
- NOTE** • When [Write[KGL_WIN=>PLC]] cannot be selected, it is necessary to stop driving external device.
Select [Change Mode] - [Stop] of the [Online] menu.
-

3.9 Setting Example 9

■ Settings of GP-Pro EX

◆ Communication Settings

To display the setting screen, select [Device/PLC Settings] from [System setting window] in workspace.

◆ Device Setting

To display the setting screen, click  ([Setting]) of External Device you want to set from [Device-Specific Settings] of [Device/PLC Settings].

When you connect multiple External Device, click  from [Device-Specific Settings] of [Device/PLC Settings] to add another External Device.

■ Settings of External Device

Communication setting of external device by ladder software (KGL_WIN).

Please refer to the manual of external device for more detail.

◆ Procedure

- 1 Connect the link I/F and the personal computer.
Turn OFF the [BUILT_IN CNET] switch.
Refer to the manual of external device for the cable used.
- 2 Start the ladder software, and make the project newly.
Select "120S" from [MK_S] of [PLC Type].
- 3 Double-click [Parameter] of the tree view and display the [Parameter] dialog box.
- 4 Click the [CommCh0] tab, and set the communication setup of external device.

Setup Items		Setup Description
Communication		Enable
Communication Method	Station Number	0
	Baud Rate	38400
	Data Bit	8
	Parity	None
	Stop Bit	1
	Communication Channel	RS232C Null Modem or RS422/485
Protocol and Mode	Dedicated	Slave

- 5 Select [Connect] of the [Online] menu.
- 6 Select [Write[KGL_WIN=>PLC]] of the [Online] menu, and download the communication setup of external device.

NOTE • When [Write[KGL_WIN=>PLC]] cannot be selected, it is necessary to stop driving external device.
Select [Change Mode] - [Stop] of the [Online] menu.

3.10 Setting Example 10

■ Settings of GP-Pro EX

◆ Communication Settings

To display the setting screen, select [Device/PLC Settings] from [System setting window] in workspace.

Device/PLC 1

Summary [Change Device/PLC](#)

Maker Driver Port

Text Data Mode [Change](#)

Communication Settings

SIO Type RS232C RS422/485(2wire) RS422/485(4wire)

Speed

Data Length 7 8

Parity NONE EVEN ODD

Stop Bit 1 2

Flow Control NONE ER(DTR/CTS) XON/XOFF

Timeout (sec)

Retry

Wait To Send (ms)

RI / VCC RI VCC

In the case of RS232C, you can select the 9th pin to RI (Input or VCC (5V Power Supply). If you use the Digital's RS232C Isolation Unit, please select it to VCC.

Device-Specific Settings

Allowable No. of Device/PLCs: 16 Unit(s)

No.	Device Name	Settings
1	PLC1	Station=0

◆ Device Setting

To display the setting screen, click ([Setting]) of External Device you want to set from [Device-Specific Settings] of [Device/PLC Settings].

When you connect multiple External Device, click from [Device-Specific Settings] of [Device/PLC Settings] to add another External Device.

Individual Device Settings

PLC1

Station

■ Settings of External Device

Communication setting of external device by ladder software (KGL_WIN).

Please refer to the manual of external device for more detail.

◆ Procedure

- 1 Connect the link I/F and the personal computer.
Turn OFF the [BUILT_IN CNET] switch.
Refer to the manual of external device for the cable used.
- 2 Start the ladder software, and make the project newly.
Select "120S" from [MK_S] of [PLC Type].
- 3 Double-click [Parameter] of the tree view and display the [Parameter] dialog box.
- 4 Click the [CommCh0] tab, and set the communication setup of external device.

Setup Items		Setup Description
Communication		Enable
Communication Method	Station Number	0
	Baud Rate	38400
	Data Bit	8
	Parity	None
	Stop Bit	1
	Communication Channel	RS232C Null Modem or RS422/485
Protocol and Mode	Dedicated	Slave

- 5 Select [Connect] of the [Online] menu.
- 6 Select [Write[KGL_WIN=>PLC]] of the [Online] menu, and download the communication setup of external device.

NOTE • When [Write[KGL_WIN=>PLC]] cannot be selected, it is necessary to stop driving external device.
Select [Change Mode] - [Stop] of the [Online] menu.

3.11 Setting Example 11

■ Settings of GP-Pro EX

◆ Communication Settings

To display the setting screen, select [Device/PLC Settings] from [System setting window] in workspace.

Device/PLC 1

Summary [Change Device/PLC](#)

Maker Driver Port

Text Data Mode [Change](#)

Communication Settings

SIO Type RS232C RS422/485(2wire) RS422/485(4wire)

Speed

Data Length 7 8

Parity NONE EVEN ODD

Stop Bit 1 2

Flow Control NONE ER(DTR/CTS) XON/XOFF

Timeout (sec)

Retry

Wait To Send (ms)

RI / VCC RI VCC

In the case of RS232C, you can select the 9th pin to RI (Input or VCC (5V Power Supply). If you use the Digital's RS232C Isolation Unit, please select it to VCC.

Device-Specific Settings

Allowable No. of Device/PLCs: 16 Unit(s)

No.	Device Name	Settings
1	PLC1	Station=0

◆ Device Setting

To display the setting screen, click ([Setting]) of External Device you want to set from [Device-Specific Settings] of [Device/PLC Settings].

When you connect multiple External Device, click from [Device-Specific Settings] of [Device/PLC Settings] to add another External Device.

Individual Device Settings

PLC1

Station

■ Settings of External Device

Communication setting of external device by ladder software (KGL_WIN).

Please refer to the manual of external device for more detail.

◆ Procedure

- 1 Connect the link I/F and the personal computer.
Turn OFF the [BUILT_IN CNET] switch.
Refer to the manual of external device for the cable used.
- 2 Start the ladder software, and make the project newly.
Select "120S" from [MK_S] of [PLC Type].
- 3 Double-click [Parameter] of the tree view and display the [Parameter] dialog box.
- 4 Click the [CommCh0] tab, and set the communication setup of external device.

Setup Items		Setup Description
Communication		Enable
Communication Method	Station Number	0
	Baud Rate	38400
	Data Bit	8
	Parity	None
	Stop Bit	1
	Communication Channel	RS232C Null Modem or RS422/485
Protocol and Mode	Dedicated	Slave

- 5 Select [Connect] of the [Online] menu.
- 6 Select [Write[KGL_WIN=>PLC]] of the [Online] menu, and download the communication setup of external device.

NOTE • When [Write[KGL_WIN=>PLC]] cannot be selected, it is necessary to stop driving external device.
Select [Change Mode] - [Stop] of the [Online] menu.

3.12 Setting Example 12

■ Settings of GP-Pro EX

◆ Communication Settings

To display the setting screen, select [Device/PLC Settings] from [System setting window] in workspace.

Device/PLC 1

Summary [Change Device/PLC](#)

Maker Driver Port

Text Data Mode [Change](#)

Communication Settings

SIO Type RS232C RS422/485(2wire) RS422/485(4wire)

Speed

Data Length 7 8

Parity NONE EVEN ODD

Stop Bit 1 2

Flow Control NONE ER(DTR/CTS) XON/XOFF

Timeout (sec)

Retry

Wait To Send (ms)

RI / VCC RI VCC

In the case of RS232C, you can select the 9th pin to RI (Input) or VCC (5V Power Supply). If you use the Digital's RS232C Isolation Unit, please select it to VCC.

Device-Specific Settings

Allowable No. of Device/PLCs: 16 Unit(s)

No.	Device Name	Settings
1	PLC1	Station=0

◆ Device Setting

To display the setting screen, click ((Setting)) of External Device you want to set from [Device-Specific Settings] of [Device/PLC Settings].

When you connect multiple External Device, click from [Device-Specific Settings] of [Device/PLC Settings] to add another External Device.

Individual Device Settings

PLC1

Station

■ Settings of External Device

Communication setting of external device by ladder software (KGL_WIN).

Please refer to the manual of external device for more detail.

◆ Procedure

- 1 Connect RS-232C port on CPU unit of external device with the personal computer.
Turn ON the [BUILT_IN CNET] switch.
Refer to the manual of external device for the cable used.
- 2 Start the ladder software, and make the project newly.
Select "80S" from [MK_S] of [PLC Type].
- 3 Double-click [Parameter] of the tree view and display the [Parameter] dialog box.
- 4 Click the [Comm] tab, and set the communication setup of external device.

Setup Items		Setup Description
Communication		Enable
Communication Method	Station Number	0
	Baud Rate	38400
	Data Bit	8
	Parity	None
	Stop Bit	1
	Communication Channel	RS232C Null Modem or RS422/485
Protocol and Mode	Dedicated	Slave

- 5 Select [Connect] of the [Online] menu.
- 6 Select [Write[KGL_WIN=>PLC]] of the [Online] menu, and download the communication setup of external device.

NOTE • When [Write[KGL_WIN=>PLC]] cannot be selected, it is necessary to stop driving external device.
Select [Change Mode] - [Stop] of the [Online] menu.

3.13 Setting Example 13

■ Settings of GP-Pro EX

◆ Communication Settings

To display the setting screen, select [Device/PLC Settings] from [System setting window] in workspace.

Device/PLC 1

Summary [Change Device/PLC](#)

Maker Driver Port

Text Data Mode [Change](#)

Communication Settings

SIO Type RS232C RS422/485(2wire) RS422/485(4wire)

Speed

Data Length 7 8

Parity NONE EVEN ODD

Stop Bit 1 2

Flow Control NONE ER(DTR/CTS) XON/XOFF

Timeout (sec)

Retry

Wait To Send (ms)

RI / VCC RI VCC

In the case of RS232C, you can select the 9th pin to RI (Input) or VCC (5V Power Supply). If you use the Digital's RS232C Isolation Unit, please select it to VCC.

Device-Specific Settings

Allowable No. of Device/PLCs: 16 Unit(s)

No.	Device Name	Settings
1	PLC1	Station=0

◆ Device Setting

To display the setting screen, click ((Setting)) of External Device you want to set from [Device-Specific Settings] of [Device/PLC Settings].

When you connect multiple External Device, click from [Device-Specific Settings] of [Device/PLC Settings] to add another External Device.

Individual Device Settings

PLC1

Station

■ Settings of External Device

Communication setting of external device by ladder software (KGL_WIN).

Please refer to the manual of external device for more detail.

◆ Procedure

- 1 Connect the link I/F and the personal computer.
Turn OFF the [BUILT_IN CNET] switch.
Refer to the manual of external device for the cable used.
- 2 Start the ladder software, and make the project newly.
Select "80S" from [MK_S] of [PLC Type].
- 3 Double-click [Parameter] of the tree view and display the [Parameter] dialog box.
- 4 Click the [Comm] tab, and set the communication setup of external device.

Setup Items		Setup Description
Communication		Enable
Communication Method	Station Number	0
	Baud Rate	38400
	Data Bit	8
	Parity	None
	Stop Bit	1
	Communication Channel	RS232C Null Modem or RS422/485
Protocol and Mode	Dedicated	Slave

- 5 Select [Connect] of the [Online] menu.
- 6 Select [Write[KGL_WIN=>PLC]] of the [Online] menu, and download the communication setup of external device.

NOTE • When [Write[KGL_WIN=>PLC]] cannot be selected, it is necessary to stop driving external device.
Select [Change Mode] - [Stop] of the [Online] menu.

3.14 Setting Example 14

■ Settings of GP-Pro EX

◆ Communication Settings

To display the setting screen, select [Device/PLC Settings] from [System setting window] in workspace.

◆ Device Setting

To display the setting screen, click  ([Setting]) of External Device you want to set from [Device-Specific Settings] of [Device/PLC Settings].

When you connect multiple External Device, click  from [Device-Specific Settings] of [Device/PLC Settings] to add another External Device.

■ Settings of External Device

Communication setting of external device by ladder software (KGL_WIN).

Please refer to the manual of external device for more detail.

◆ Procedure

- 1 Connect the link I/F and the personal computer.
Turn OFF the [BUILT_IN CNET] switch.
Refer to the manual of external device for the cable used.
- 2 Start the ladder software, and make the project newly.
Select "80S" from [MK_S] of [PLC Type].
- 3 Double-click [Parameter] of the tree view and display the [Parameter] dialog box.
- 4 Click the [Comm] tab, and set the communication setup of external device.

Setup Items		Setup Description
Communication		Enable
Communication Method	Station Number	0
	Baud Rate	38400
	Data Bit	8
	Parity	None
	Stop Bit	1
	Communication Channel	RS232C Null Modem or RS422/485
Protocol and Mode	Dedicated	Slave

- 5 Select [Connect] of the [Online] menu.
- 6 Select [Write[KGL_WIN=>PLC]] of the [Online] menu, and download the communication setup of external device.

NOTE • When [Write[KGL_WIN=>PLC]] cannot be selected, it is necessary to stop driving external device.
Select [Change Mode] - [Stop] of the [Online] menu.

3.15 Setting Example 15

■ Settings of GP-Pro EX

◆ Communication Settings

To display the setting screen, select [Device/PLC Settings] from [System setting window] in workspace.

Device/PLC 1

Summary [Change Device/PLC](#)

Maker Driver Port

Text Data Mode [Change](#)

Communication Settings

SIO Type RS232C RS422/485(2wire) RS422/485(4wire)

Speed

Data Length 7 8

Parity NONE EVEN ODD

Stop Bit 1 2

Flow Control NONE ER(DTR/CTS) XON/XOFF

Timeout (sec)

Retry

Wait To Send (ms)

RI / VCC RI VCC

In the case of RS232C, you can select the 9th pin to RI (Input or VCC (5V Power Supply). If you use the Digital's RS232C Isolation Unit, please select it to VCC.

Device-Specific Settings

Allowable No. of Device/PLCs: 16 Unit(s)

No.	Device Name	Settings
1	PLC1	Station=0

◆ Device Setting

To display the setting screen, click ([Setting]) of External Device you want to set from [Device-Specific Settings] of [Device/PLC Settings].

When you connect multiple External Device, click from [Device-Specific Settings] of [Device/PLC Settings] to add another External Device.

Individual Device Settings

PLC1

Station

■ Settings of External Device

Communication setting of external device by ladder software (KGL_WIN).

Please refer to the manual of external device for more detail.

◆ Procedure

- 1 Connect the link I/F and the personal computer.
Turn OFF the [BUILT_IN CNET] switch.
Refer to the manual of external device for the cable used.
- 2 Start the ladder software, and make the project newly.
Select "80S" from [MK_S] of [PLC Type].
- 3 Double-click [Parameter] of the tree view and display the [Parameter] dialog box.
- 4 Click the [Comm] tab, and set the communication setup of external device.

Setup Items		Setup Description
Communication		Enable
Communication Method	Station Number	0
	Baud Rate	38400
	Data Bit	8
	Parity	None
	Stop Bit	1
	Communication Channel	RS232C Null Modem or RS422/485
Protocol and Mode	Dedicated	Slave

- 5 Select [Connect] of the [Online] menu.
- 6 Select [Write[KGL_WIN=>PLC]] of the [Online] menu, and download the communication setup of external device.

NOTE • When [Write[KGL_WIN=>PLC]] cannot be selected, it is necessary to stop driving external device.
Select [Change Mode] - [Stop] of the [Online] menu.

4 Setup Items

Set communication settings of the Display with GP-Pro EX or in off-line mode of the Display.

The setting of each parameter must be identical to that of External Device.

☞ "3 Example of Communication Setting" (page 6)

4.1 Setup Items in GP-Pro EX

■ Communication Settings

To display the setting screen, select [Device/PLC Settings] from [System setting window] in workspace.

Device/PLC 1

Summary [Change Device/PLC](#)

Maker Driver Port

Text Data Mode [Change](#)

Communication Settings

SIO Type RS232C RS422/485(2wire) RS422/485(4wire)

Speed

Data Length 7 8

Parity NONE EVEN ODD

Stop Bit 1 2

Flow Control NONE ER(DTR/CTS) XON/XOFF

Timeout (sec)

Retry

Wait To Send (ms)

RI / VCC RI VCC

In the case of RS232C, you can select the 9th pin to RI (Input) or VCC (5V Power Supply). If you use the Digital's RS232C Isolation Unit, please select it to VCC.

Device-Specific Settings

Allowable No. of Device/PLCs: 16 Unit[s]

No.	Device Name	Settings
1	PLC1	Station=0

Setup Items	Setup Description
SIO Type	Select the SIO type to communicate with the External Device.
Speed	Select speed between the External Device and the Display.
Data Length	Select data length.
Parity	Select how to check parity.
Stop Bit	Select stop bit length.
Flow Control	Display the communication control method to prevent overflow of transmission and reception data.
Timeout	Use an integer from 1 to 127 to enter the time (s) for which the Display waits for the response from the External Device.
Retry	In case of no response from the External Device, use an integer from 0 to 255 to enter how many times the Display retransmits the command.
Wait To Send	Use an integer from 0 to 255 to enter standby time (ms) for the Display from receiving packets to transmitting next commands.
RI/VCC	You can switch RI/VCC of the 9th pin when you select RS232C for SIO type

◆ Device Setting

To display the setting screen, click  ([Setting]) of External Device you want to set from [Device-Specific Settings] of [Device/PLC Settings].

When you connect multiple External Device, click  from [Device-Specific Settings] of [Device/PLC Settings] to add another External Device

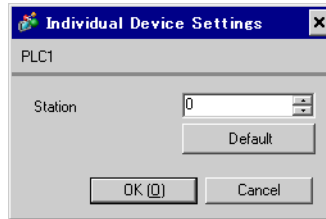

Setup Items	Setup Description
Station	Use an integer from 1 to 31 to enter the Station No. of the External Device. (Initial value [0])

4.2 Setup Items in Off-Line Mode

NOTE

- Please refer to GP3000 Series User Manual for more information on how to enter off-line mode or about operation.

Cf. GP3000 Series User Manual "Chapter 4 Settings"

◆ Communication Settings

To display the setting screen, touch [Device/PLC Settings] from [Peripheral Settings] in off-line mode. Touch the External Device you want to set from the displayed list.

Comm.	Device	Option		
Master-K Series Cnet			[COM1]	Page 1/1
SIO Type	RS232C			
Speed	38400			
Data Length	<input type="radio"/> 7	<input checked="" type="radio"/> 8		
Parity	<input checked="" type="radio"/> NONE	<input type="radio"/> EVEN	<input type="radio"/> ODD	
Stop Bit	<input checked="" type="radio"/> 1	<input type="radio"/> 2		
Flow Control	NONE			
Timeout(s)	3	▼ ▲		
Retry	2	▼ ▲		
Wait To Send(ms)	0	▼ ▲		
	Exit		Back	2006/05/15 11:28:50

Setup Items	Setup Description
SIO Type	Select the SIO type to communicate with the External Device.
Speed	Select speed between the External Device and the Display.
Data Length	Select data length.
Parity	Select how to check parity.
Stop Bit	Select stop bit length.
Flow Control	Display the communication control method to prevent overflow of transmission and reception data.
Timeout	Use an integer from 1 to 127 to enter the time (s) for which the Display waits for the response from the External Device.
Retry	In case of no response from the External Device, use an integer from 0 to 255 to enter how many times the Display retransmits the command.
Wait To Send	Use an integer from 0 to 255 to enter standby time (ms) for the Display from receiving packets to transmitting next commands.

■ Device Setting

To display the setting screen, touch [Device/PLC Settings] from [Peripheral Settings]. Touch the External Device you want to set from the displayed list, and touch [Device].

Comm.	Device	Option		
Master-K Series Cnet			[COM1]	Page 1/1
Device/PLC Name	[PLC1] ▼			
Station	[0] ▼ ▲			
	Exit		Back	2006/05/15 11:28:53

Setup Items	Setup Description
Device/PLC Name	Select the External Device for device setting. Device name is a title of External Device set with GP-Pro EX.(Initial value [PLC1])
Station	Use an integer from 0 to 31 to enter the Station No. of the External Device. (Initial value [0])

◆ Option

To display the setting screen, touch [Device/PLC Settings] from [Peripheral Settings]. Touch the External Device you want to set from the displayed list, and touch [Option].

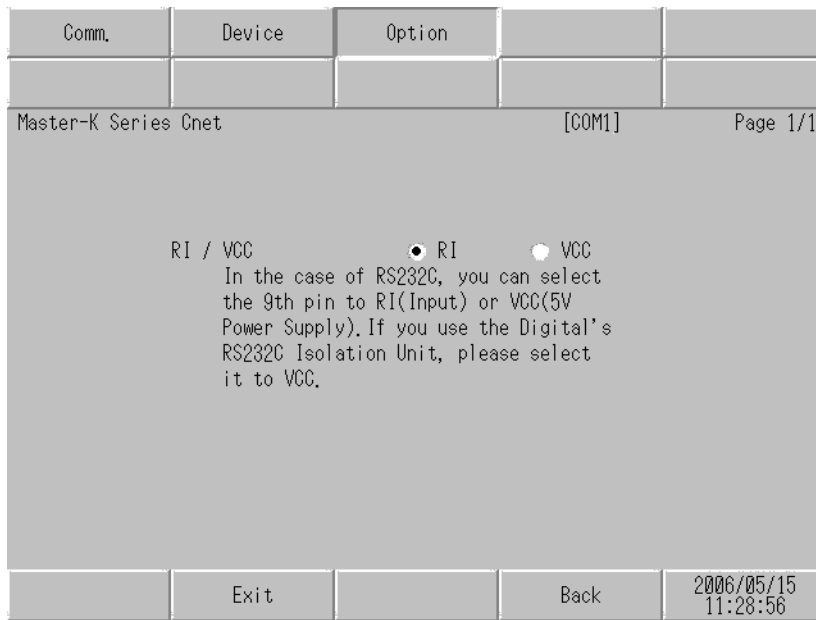

Setup Items	Setup Description
RI/VCC	You can switch RI/VCC of the 9th pin when you select RS232C for SIO type

5 Cable Diagram

The cable diagram shown below may be different from the cable diagram recommended by LS Industrial Systems. Please be assured there is no operational problem in applying the cable diagram shown in this manual.

- The FG pin of the External Device body must be D-class grounded. Please refer to the manual of the External Device for more details.
- SG and FG are connected inside the Display. When connecting SG to the External Device, design the system not to form short-circuit loop.

Cable Diagram 1

Display (Connection Port)	Cable	Notes
GP (COM1)	Your own cable	The cable length must be 15m or less.

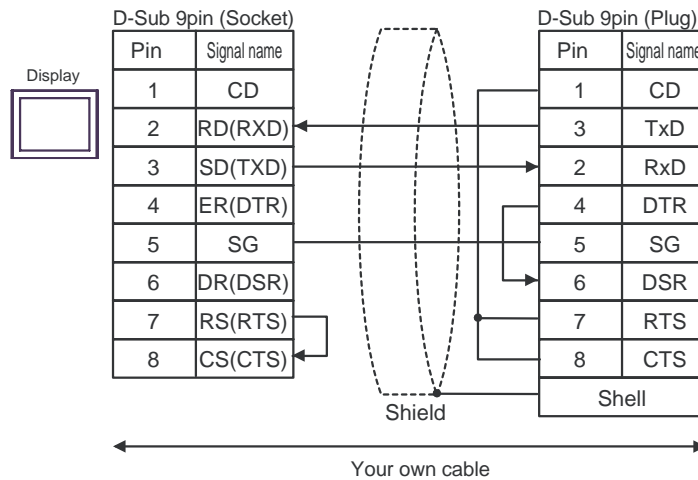

Cable Diagram 2

Display (Connection Port)	Cable		Notes
GP (COM1) ^{*1} AGP-3302 (COM2)	A	COM port conversion adapter (for COM1) by Pro-face CA3-ADPCOM-01 + Connector terminal block conversion adapter by Pro-face CA3-ADPTRM-01 + Your own cable	The cable length must be 500m or less.
	B	Your own cable	
GP (COM2) ^{*1}	C	Online adapter by Pro-face CA4-ADPONL-01 + Connector terminal block conversion adapter by Pro-face CA3-ADPTRM-01 + Your own cable	
	D	Online adapter by Pro-face CA4-ADPONL-01 + Your own cable	

*1 All GP models except AGP-3302

A) When using the COM port conversion adapter (CA3-ADPCOM-01), the connector terminal block conversion adapter (CA3-ADPTRM-01) by Pro-face and your own cable

- 1:1 Connection

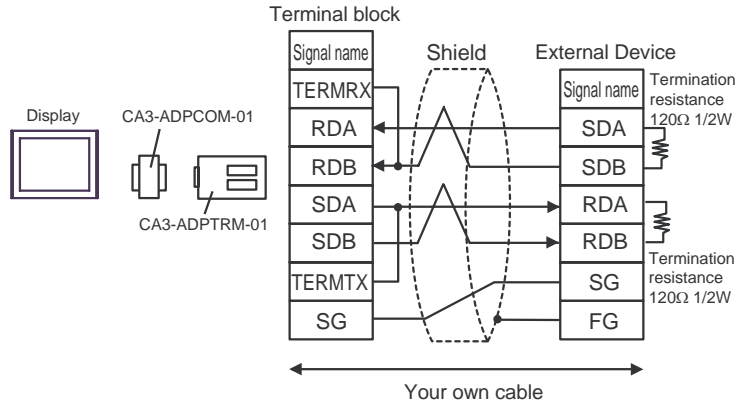

- 1:n Connection

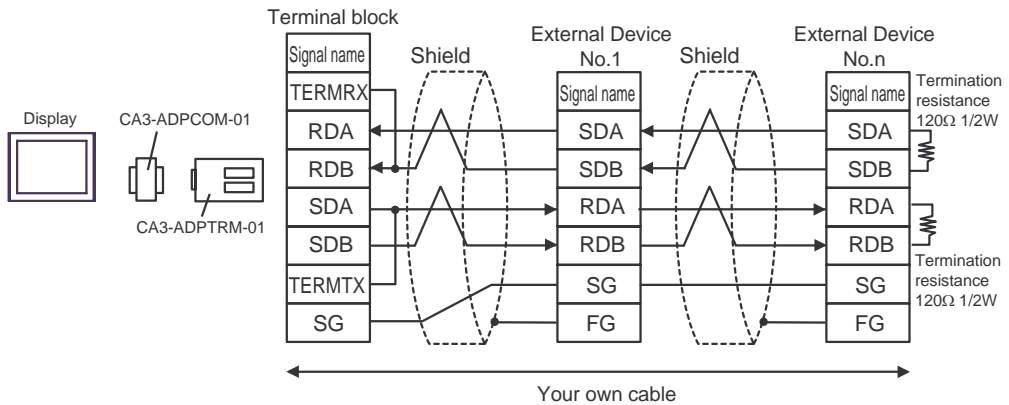

B) When using your own cable

- 1:1 Connection

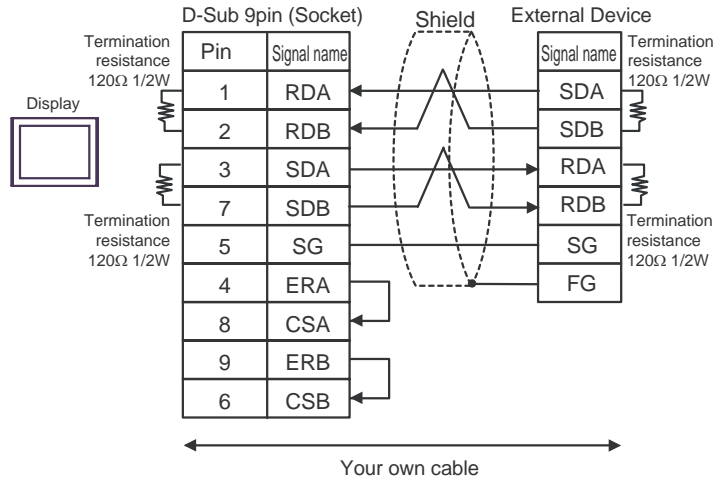

- 1:n Connection

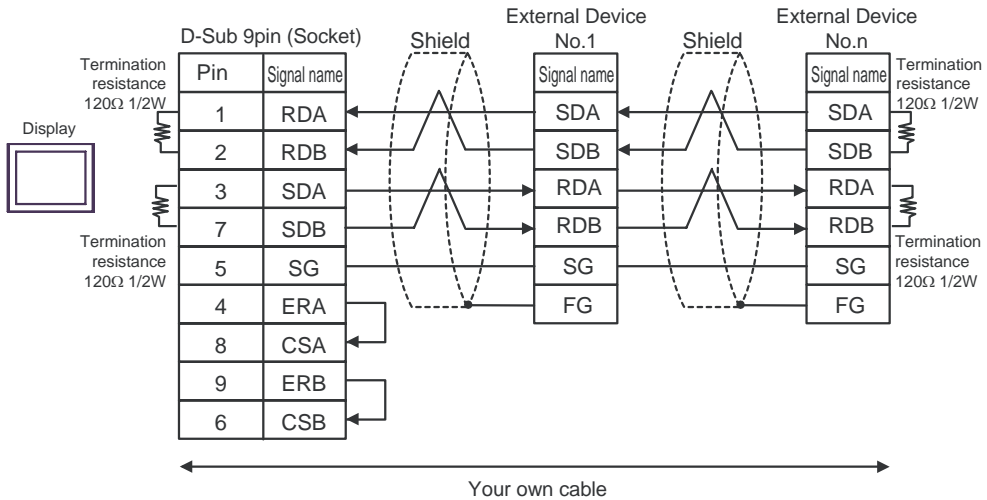

C) When using the online adapter (CA4-ADPONL-01), the connector terminal block conversion adapter (CA3-ADPTRM-01) by Pro-face and your own cable

- 1:1 Connection

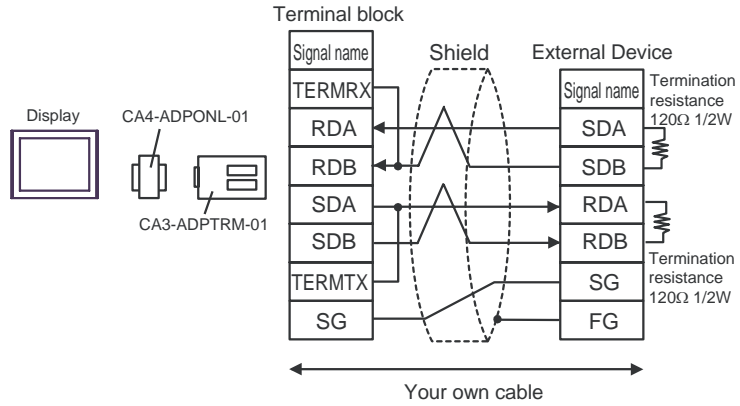

- 1:n Connection

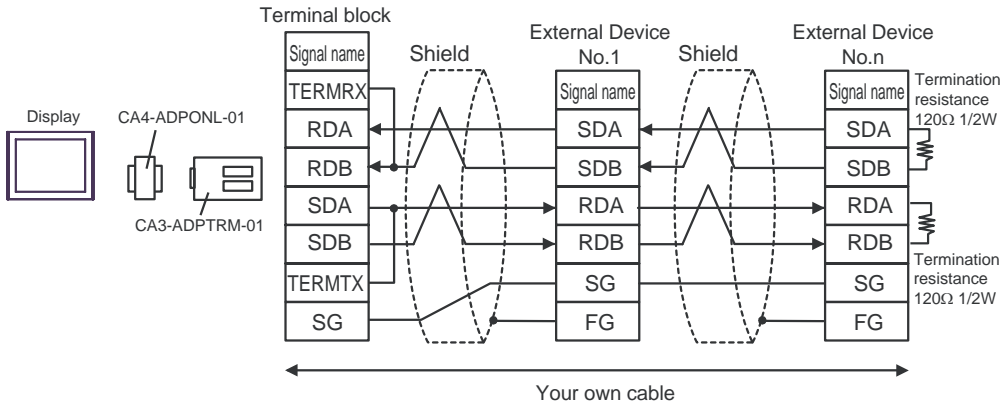

D) When using the online adapter (CA4-ADPONL-01) by Pro-face and your own cable

- 1:1 Connection

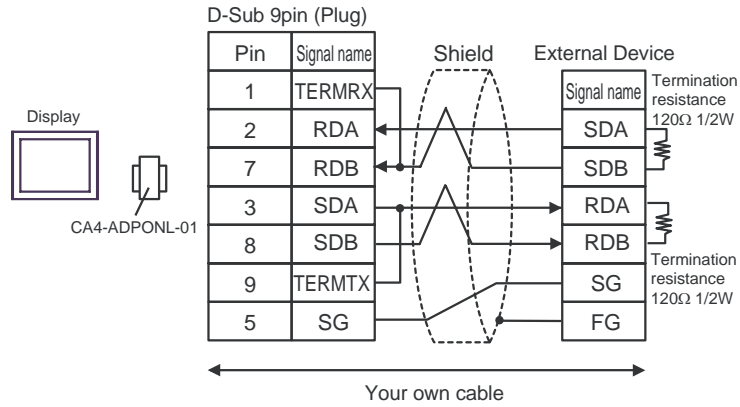

- 1:n Connection

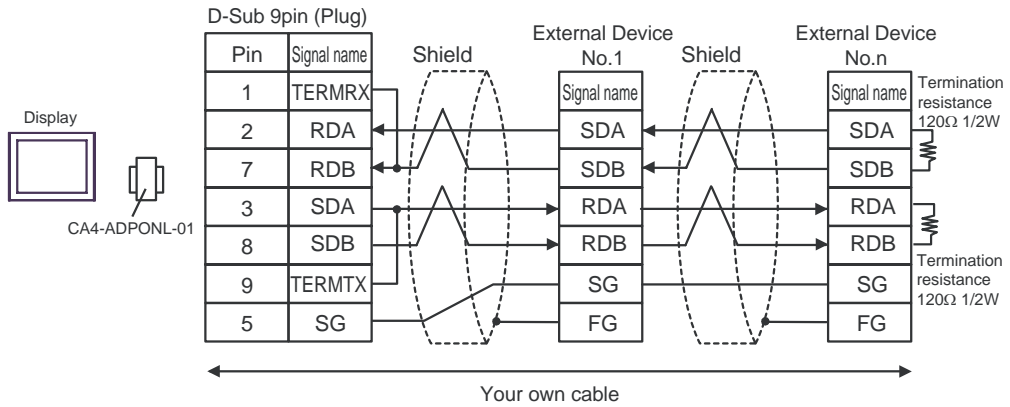

Cable Diagram 3

Display (Connection Port)	Cable		Notes
GP (COM1) ^{*1} AGP-3302 (COM2)	A	COM port conversion adapter (for COM1) by Pro-face CA3-ADPCOM-01 + Connector terminal block conversion adapter by Pro-face CA3-ADPTRM-01 + Your own cable	The cable length must be 500m or less.
	B	Your own cable	
GP (COM2) ^{*1}	C	Online adapter by Pro-face CA4-ADPONL-01 + Connector terminal block conversion adapter by Pro-face CA3-ADPTRM-01 + Your own cable	
	D	Online adapter by Pro-face CA4-ADPONL-01 + Your own cable	

*1 All GP models except AGP-3302

A) When using the COM port conversion adapter (CA3-ADPCOM-01), the connector terminal block conversion adapter (CA3-ADPTRM-01) by Pro-face and your own cable

- 1:1 Connection

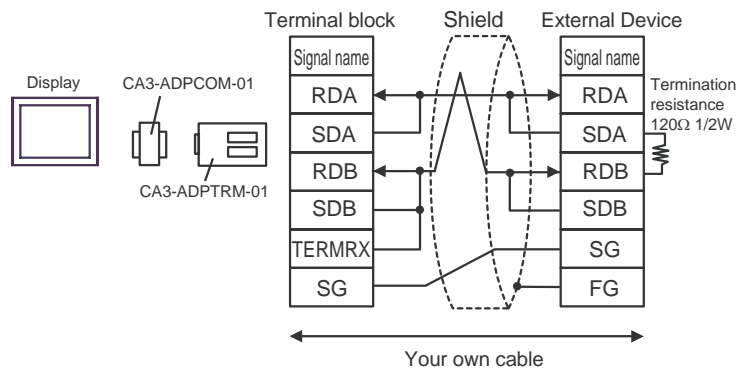

B) When using your own cable

- 1:1 Connection

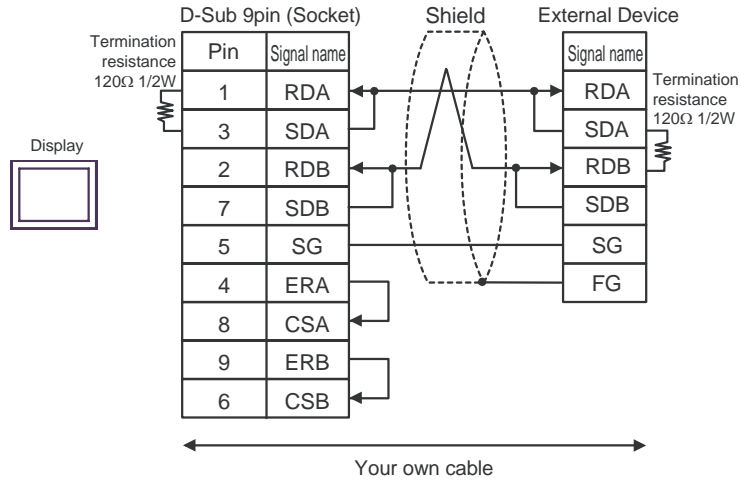

C) When using the online adapter (CA4-ADPONL-01), the connector terminal block conversion adapter (CA3-ADPTRM-01) by Pro-face and your own cable

- 1:1 Connection

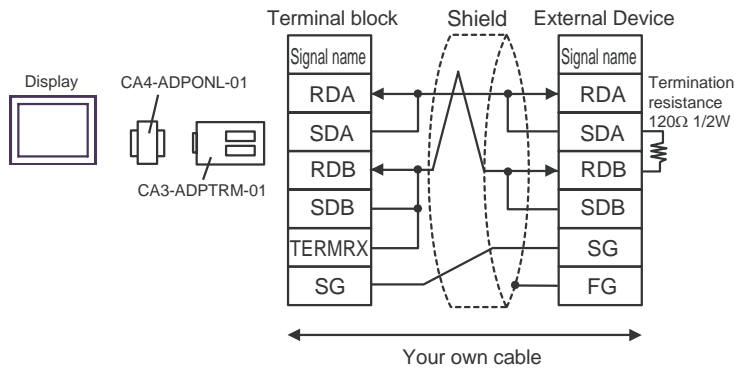

D) When using the online adapter (CA4-ADPONL-01) by Pro-face and your own cable

- 1:1 Connection

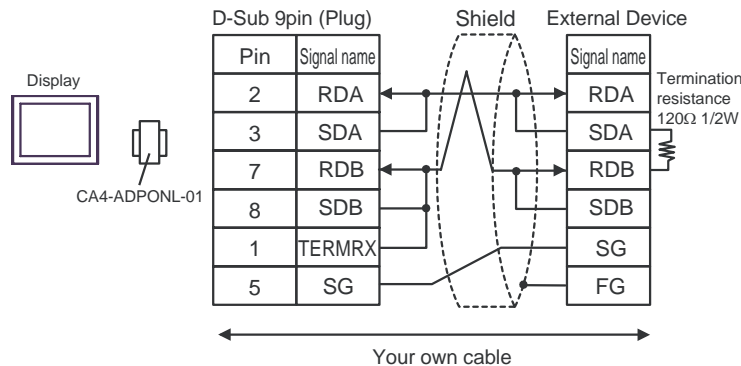

Cable Diagram 4

Display (Connection Port)	Cable	Notes
GP (COM1)	Your own cable	The cable length must be 15m or less.

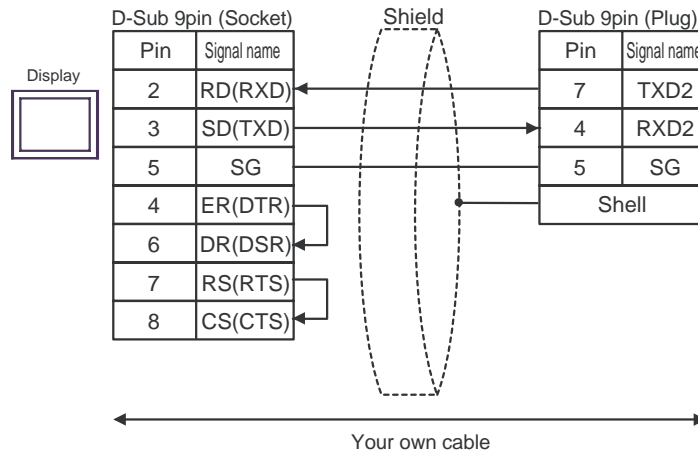

Cable Diagram 5

Display (Connection Port)	Cable		Notes
GP (COM1) ^{*1} AGP-3302 (COM2)	A	COM port conversion adapter (for COM1) by Pro-face CA3-ADPCOM-01 + Connector terminal block conversion adapter by Pro-face CA3-ADPTRM-01 + Your own cable	The cable length must be 500m or less.
	B	Your own cable	
GP (COM2) ^{*1}	C	Online adapter by Pro-face CA4-ADPONL-01 + Connector terminal block conversion adapter by Pro-face CA3-ADPTRM-01 + Your own cable	
	D	Online adapter by Pro-face CA4-ADPONL-01 + Your own cable	

*1 All GP models except AGP-3302

A) When using the COM port conversion adapter (CA3-ADPCOM-01), the connector terminal block conversion adapter (CA3-ADPTRM-01) by Pro-face and your own cable

- 1:1 Connection

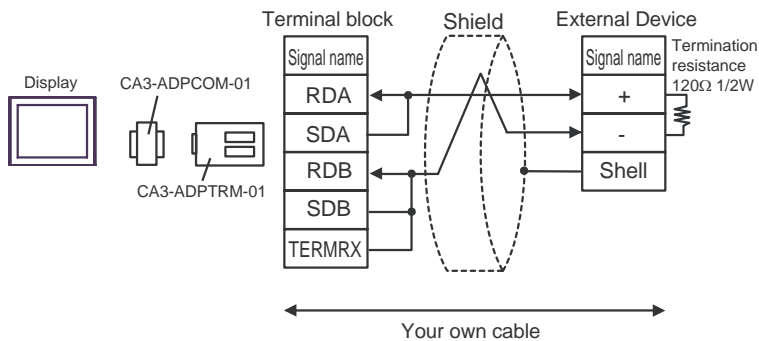

B) When using your own cable

- 1:1 Connection

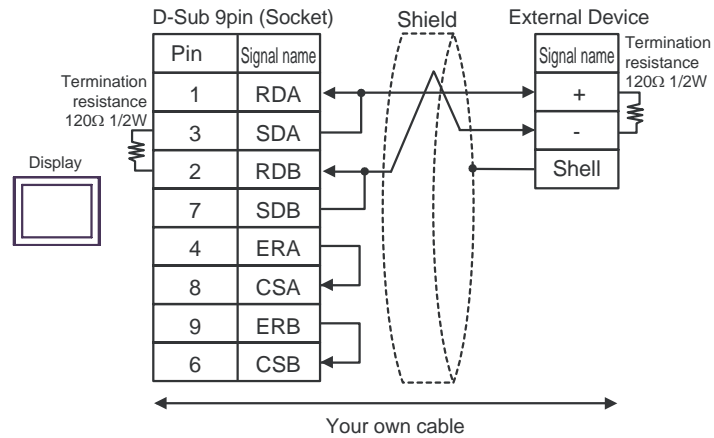

C) When using the online adapter (CA4-ADPONL-01), the connector terminal block conversion adapter (CA3-ADPTRM-01) by Pro-face and your own cable

- 1:1 Connection

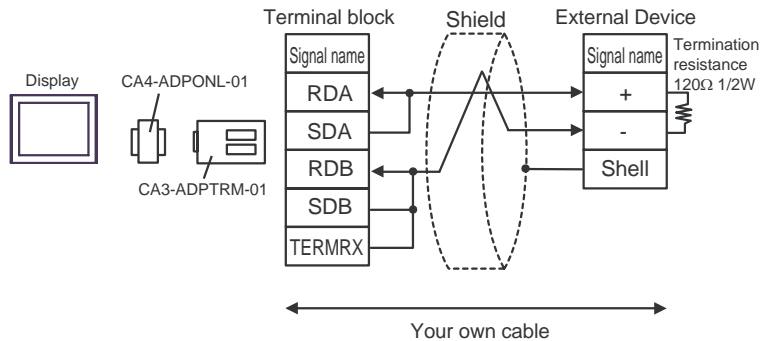

D) When using the online adapter (CA4-ADPONL-01) by Pro-face and your own cable

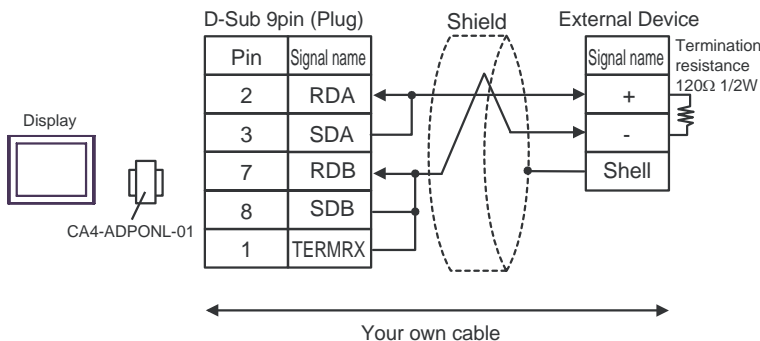

- 1:1 Connection



6 Supported Device

Range of supported device address is shown in the table below. Please note that the actually supported range of the devices varies depending on the External Device to be used. Please check the actual range in the manual of your connecting equipment.

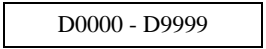
 This address can be specified as system data area.

Device	Bit Address	Word Address	32 bits	Notes
Input / Output Relay	P000 - P63F	P00 - P63		
Auxiliary Relay	M0000 - M191F	M000 - M191		
Keep Relay	K000 - K31F	K00 - K31		
Link Relay	L000 - L63F	L00 - L63		
Special Relay	F000 - F63F	F00 - F63		*1
Timer (Contact)	T000 - T255	-----		
Counter (Contact)	C000 - C255	-----		
Timer (Elapsed Value)	-----	T000 - T255		
Counter (Elapsed Value)	-----	C000 - C255		
Step Controller	-----	S00 - S99		
Data Register	-----	 D0000 - D9999		

*1 Write disable.

NOTE

- Please refer to the GP-Pro EX Reference Manual for system data area.
Cf. GP-Pro EX Reference Manual "Appendix 1.4 LS Area (only for direct access method)"
- Please refer to the precautions on manual notation for icons in the table.
 "Manual Symbols and Terminology"

7 Device Code and Address Code

Use device code and address code when you select "Device Type & Address" for the address type in data displays.

Device	Device Name	Device Code (HEX)	Address Code
Input / Output Relay	P	0080	Word address
Auxiliary Relay	M	0082	Word address
Keep Relay	K	0083	Word address
Link Relay	L	0084	Word address
Special Relay	F	0085	Word address
Timer (Elapsed Value)	T	0060	Word address
Counter (Elapsed Value)	C	0061	Word address
Step Controller	S	0062	Word address
Data Register	D	0000	Word address

8 Error Messages

Error messages are displayed on the screen of Display as follows: "No. : Device Name: Error Message (Error Occurrence Area)". Each description is shown below.

Item	Description
No.	Error No.
Device Name	Name of External Device where error occurs. Device name is a title of External Device set with GP-Pro EX. (Initial value [PLC1])
Error Message	Displays messages related to the error which occurs.
Error Occurrence Area	Displays IP address or device address of External Device where error occurs, or error codes received from External Device. <div style="border: 1px solid black; padding: 2px; display: inline-block;">NOTE</div> <ul style="list-style-type: none"> • IP address is displayed such as "IP address (Decimal): MAC address (Hex)". • Device address is displayed such as "Address: Device address". • Received error codes are displayed such as "Decimal [Hex]".

Display Examples of Error Messages

"RHAA035: PLC1: Error has been responded for device write command (Error Code: 2 [02H])"

NOTE

- Please refer to the manual of External Device for more detail of received error codes.
